

GMC
WE ARE PROFESSIONAL GRADE

2018
SIERRA



POWER LIKE A PRO

The 2018 Sierra elevates the pickup again. It's the truck revered for its bold design, robust capability and comfortably quiet cabin. Sierra offers available tri-mode power steps, powerful and efficient V-8s, Magnetic Ride Control and Active Noise Cancellation. It's a reminder that the same passion and purpose that drive you also drive us. We set our own standards, proving that Professional Grade isn't merely a label, it's a way of life. Sierra is a shining example of how we take a strong stance for what we believe in and pursue it like a pro.



SIERRA CREW CAB SLT IN QUICKSILVER METALLIC (left)
SIERRA DENALI ULTIMATE CREW CAB IN DARK SLATE METALLIC (center)
SIERRA ALL TERRAIN DOUBLE CAB SLT IN RED QUARTZ TINTCOAT (right)
Vehicles shown with available equipment.



DESIGN

SOME ARTISTS SIGN THEIR WORK. OTHERS SIMPLY FORGE THEIR OWN UNMISTAKABLE STYLE. ON SIERRA, WE DID BOTH.

DENALI

MAKES A POWERFUL IMPRESSION

Our designers love details as much as our engineers do. A prime example is Sierra Denali—a premium pickup like no other. It begins with a bold, sculpted front design, Denali-exclusive grille, GMC signature C-shaped high-performance projector-beam LED headlamps, thin-profile LED fog lamps and LED taillamps. In addition, we've taken Denali's style, craftsmanship and capability to a higher level on 4WD models by offering the Sierra Denali Ultimate. It includes a 6.2L, 420-hp V-8 paired with an 8-speed automatic transmission, 22" wheels with chrome inserts, chrome recovery hooks, a power sunroof and tri-mode power steps to make this the ultimate expression of our Professional Grade trucks.

- + Magnetic Ride Control
- + Enhanced Driver Alert Package With Low Speed Forward Automatic Braking
- + 420-hp 6.2L V-8 Engine (Available)
- + 22" Aluminum Wheels (Available)
- + Tri-Mode Power Steps (Available)



SIERRA DENALI ULTIMATE IN DARK SLATE METALLIC shown with available equipment.

TUNES IN WHAT YOU LIKE. TUNES OUT WHAT YOU DON'T.

Sierra Denali is crafted to create the ultimate cabin. Your solitude comes from triple door seals, sound-absorbing materials and an inlaid design that fits the doors precisely into the body. It's the ideal environment to enjoy the GMC Infotainment System¹ with the full-color 8" diagonal touch-screen and Apple CarPlay™ and Android Auto™ compatibility,² Bose® audio, available 4G Wi-Fi® hotspot³ and the turn-by-turn guidance of the Navigation System.⁴ We've also taken attention to detail a step further with a soft-touch instrument panel, burnished aluminum trim, contrasting stitching and Denali-embroidered head restraints. And to keep you powered up, Sierra Denali includes a center console wireless charging mat⁵ for use with a variety of smartphones and other mobile devices.

+ 12-Way Power Front Seats With Driver Memory

+ Heated and Ventilated Premium Leather-Appointed Front Bucket Seats

+ Bose Premium Seven-Speaker Audio System With Subwoofer

+ Hand-Stitched and Heated Leather-Wrapped Steering Wheel

+ Bose Active Noise Cancellation (Included and Only Available With 6.2L V-8 Engine)

¹Full functionality requires compatible Bluetooth® and smartphone. Some devices require USB connectivity. Data plan rates apply. ²Vehicle user interfaces are products of Apple® and Google™ and their terms and privacy statements apply. Requires compatible smartphone. Data plan rates apply. ³Requires a compatible mobile device, active OnStar service and data plan. 4G service available in select markets. Visit onstar.com for coverage map, details and system limitations. Data plan provided by AT&T.® ⁴Map coverage available in the United States, Puerto Rico and Canada. ⁵The system wirelessly charges one PMA- or Qi-compatible mobile device. Some devices require an adapter or back cover. To check for phone or other device compatibility, visit my.gmc.com/learn for details.



SIERRA DENALI CREW CAB INTERIOR IN JET BLACK
shown with available equipment.

SLT

BOLD ISN'T ONLY SKIN DEEP

GMC designers formed the distinctive shape of Sierra SLT with a clear understanding of what you demand in a truck without sacrificing style, capability, power or efficiency. It begins up front with available signature C-shaped projector-beam LED lighting and standard LED fog lamps and, in the rear, LED taillamps. Providing the power and efficiency are three engine options: the standard 5.3L V-8, the available 5.3L V-8 with eAssist and the 6.2L V-8 (the most V-8 horsepower in its class¹). As always, Sierra SLT surrounds its premium cabin with chrome accents and bold wheels.



SIERRA SLT CREW CAB IN ONYX BLACK (left)
SIERRA SLT CREW CAB IN WHITE FROST TRICOAT (right)
Vehicles shown with available equipment.

¹Class is half-ton pickups.

WE'VE REFINED THE TRUCK CABIN

Designing a premium truck environment in SLT that you actually want to spend time in means surrounding you with comfortable, supportive seats as well as luxurious materials. It also means that Crew Cabs offer spacious rear leg room, while Double Cabs feature forward-hinged rear doors to make getting into and out of the rear seat easier. You'll also enjoy these SLT features.

- + Remote Vehicle Start
- + 10-Way Heated, Leather-Appointed Front Seats
- + Two-Position Driver-Seat Memory
- + Power-Adjustable Pedals
- + Dual-Zone Automatic Climate Controls



SIERRA SLT CREW CAB INTERIOR IN COCOA/DUNE
shown with available equipment.

ALL TERRAIN

THE BEST ROADS ARE THE ONES YOU CREATE

Keep going long after the pavement ends. Sierra All Terrain conquers challenging landscapes while helping to keep you in control. And no matter how rugged the going gets, its cabin is refined and comfortable.

Exclusive All Terrain Design To match its off-road capability, the new All Terrain exterior features body-color door handles, bodyside molding, grille surround and bumpers, black mirror caps and beltline molding, thin-profile LED fog lamps and LED taillamps. The distinctive interior provides a supportive environment with carbon-fiber-inspired accents, unique All Terrain leather-appointed seating with contrasting red stitching and special dark aluminum IP trim.

Off-Road Suspension Featuring monotube Rancho® shocks, the legendary Z71 suspension allows you to go beyond mere sightseeing to truly explore the great outdoors. Venturing off-pavement means encountering just about anything, so an underbody shield helps protect vital components under the truck.

AutoTrac 4WD Transfer Case This 2-speed 4WD system features both high- and low-range settings and is ideal when traction conditions are variable. When driving in AUTO, the front axle is engaged and power is sent to the front and rear wheels automatically, based on the driving situation.

Off-Road Inclinometer To provide an accurate measure of your angle of pitch and roll while venturing off road, Sierra All Terrain includes a real-time gauge in the Driver Information Center.

High-Capacity Air Filter With off-road adventures come all sorts of dirt or debris attempting to invade the engine. The air filter is engineered with a large filter area that requires changing less often.

Unique All Terrain Wheels and Tires 20" ultra-bright machined aluminum wheels with dark painted accents are available. The all-terrain tires are designed to perform on-road and off.

Hill Descent Control Activated by pushing a button that's easy to reach, this available feature uses antilock braking for a smooth and controlled hill descent under certain conditions without you having to touch the brake pedal.



ALL TERRAIN X

GO WHERE YOUR MIND HAS BEEN ALL WEEK

With Sierra All Terrain at its core, we crafted the Sierra All Terrain X Package so you can live out your weekday dreams. To help you venture farther away from it all and conquer more challenging environments, we've heightened its rugged capabilities. We've added premium features and dialed up its aggressive, monochromatic design. All Terrain X is available on Sierra SLT 4WD Crew Cab Short Box and Double Cab Standard Box models. Starting with standard All Terrain content, the X includes additional features.

All Terrain X Tires The 265/65R18SL Mud-Terrain-rated Goodyear® Wrangler DuraTrac® MT tires are designed for off-road competence in dirt, gravel and mud, with on-road composure in dry, wet or wintry conditions.

18" Wheels These black painted aluminum wheels add to its stealth look.

Black Sport Side Steps Gain easy access into the truck cabin.

Black Bed-Mounted Sport Bar Designed to support the available accessory off-road LED lighting package (shown) for illumination in any environment.

High-Performance Projector-Beam LED Headlamps The dark of night shouldn't stop your off-road adventures.

Engines A 5.3L V-8 with Direct Injection (DI), Variable Valve Timing (VVT) and Active Fuel Management (AFM) is standard. A 420-hp 6.2L V-8 is available.

Performance Exhaust System Included only with the 5.3L V-8, it increases horsepower and adds an aggressive exhaust note.

Exterior Colors Choose your Sierra All Terrain X in Onyx Black, Summit White, Stone Blue Metallic,¹ Dark Slate Metallic,¹ Red Quartz Tintcoat¹ or Deep Mahogany Metallic.¹



SIERRA ALL TERRAIN X CREW CAB IN ONYX BLACK (left and right)
Vehicles shown with available equipment.
¹Additional charge, premium paint.



SIERRA ELEVATION EDITION DOUBLE CAB IN ONYX BLACK shown with available equipment.

ELEVATION

IT SHINES EVEN WITHOUT CHROME

The Elevation Edition takes legendary Professional Grade engineering and adds an exclusive attitude. Its monochromatic body—available in Onyx Black, Summit White, Dark Slate Metallic¹ and Stone Blue Metallic¹—tells the world that something unique is headed their way with high style and surprising value. Elevation is available on Sierra models in a Double-Cab configuration and on SLE in either Double Cab or Crew Cab configurations.

Body-Color Design Its monochromatic appearance is created with matching body-color bumpers, side moldings, grille surround, door handles and mirror caps.

Signature C-Shaped Projector-Beam LED Lighting Elevation includes HID headlamps and thin-profile LED fog lamps.

20" Black Painted Aluminum Wheels The 20" machined wheels shown are painted high-gloss black with matching caps and raised GMC logos. Elevation is also available with 20" bright machined aluminum wheels.

¹Additional charge, premium paint.



ENGINEERING

SINCE GMC FIRST INTRODUCED THE PROFESSIONAL GRADE TRUCK, WE'VE PUSHED THE BOUNDS OF PHYSICS, SCIENCE AND MATHEMATICS TO CONTINUOUSLY SET HIGHER STANDARDS OF EXCELLENCE.

HORSEPOWER DRIVEN BY BRAINPOWER

In Sierra, it's as much about outsmarting as it is about overpowering the laws of physics. That's why Sierra's EcoTec3 engines think before responding to driver inputs to generate power efficiently. Take Active Fuel Management (AFM): By sensing load and demand, AFM improves efficiency by activating or deactivating cylinders. Under demanding conditions, such as high speeds or heavy loads, the valves' switching mechanism is depressurized, reengaging the cylinder and restoring full power.

420
HORSEPOWER

460
lb-ft of
TORQUE

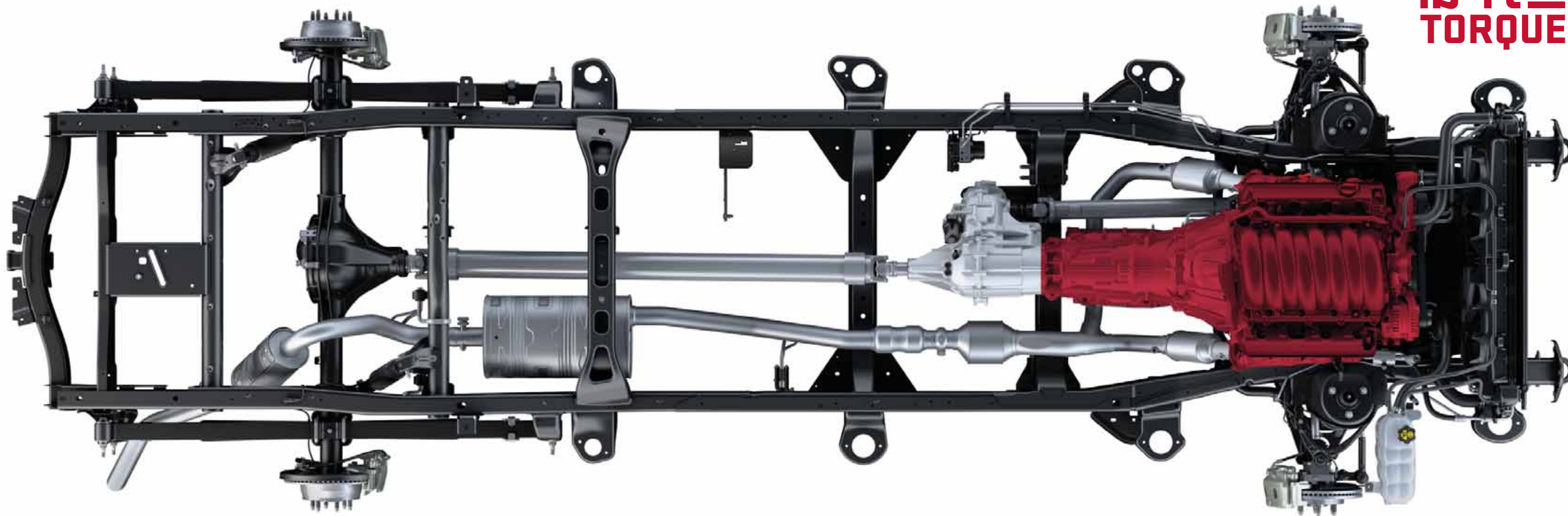

PERFORMANCE TECHNOLOGIES

Sierra's EcoTec3 4.3L V-6, 5.3L V-8, 5.3L V-8 with eAssist and 6.2L V-8 engines feature Direct Injection (DI) and continuously Variable Valve Timing (VVT) as well as Active Fuel Management (AFM) to deliver power and efficiency. In fact, the available 5.3L V-8 with eAssist offers both 355 hp and up to 24 mpg hwy,¹ while the available 6.2L V-8 offers 420 hp with up to 21 mpg hwy.¹ An 8-speed automatic transmission is standard on Denali and available on select SLT models.

Active Fuel Management Only uses the cylinders it needs to save fuel (deactivating two on the V-6 and four on the V-8).

Direct Injection Produces precise fuel distribution and fast, efficient combustion.

Variable Valve Timing Responsive in low-speed and open-road passing or trailering.

Piston Cooling Sprays oil under pistons and on cylinder walls to maximize power and durability.

5.3L V-8 With eAssist Technology Additional fuel optimization is achieved using Stop/Start technology, electric power boost, regenerative braking and lithium-ion battery pack (available).

6.2L V-8 Offers the most V-8 horsepower in its class.²

¹EPA-estimated mpg for 4.3L EcoTec3 engine: 18 city/24 hwy (2WD), 17 city/22 hwy (4WD); 5.3L EcoTec3 engine: 16 city/23 hwy with 6-speed automatic transmission (2WD), 16 city/22 hwy with 6-speed automatic transmission (4WD), 16 city/22 hwy with 8-speed automatic transmission (2WD), 15 city/20 hwy with 8-speed automatic transmission (4WD); 5.3L EcoTec3 engine with eAssist: 18 city/24 hwy with 8-speed automatic transmission (2WD), 16 city/21 hwy with 8-speed automatic transmission (4WD); 6.2L EcoTec3 engine: 15 city/21 hwy (2WD), 15 city/20 hwy (4WD).
²Class is half-ton pickups.

ROADS CHANGE IN A SECOND. SO DOES THE SUSPENSION.

Road surfaces go from smooth to uneven and rough or from straight to curvy without warning. That's why Sierra Denali features standard Magnetic Ride Control, a class-exclusive¹ suspension system that speed-reads the road up to 1,000 times a second, thinks and responds to changes in the road long before you ever could. All you have to do is feel a more comfortable, controlled ride.



Cruising
On smooth roads, the iron particles in the patented magnetorheological fluid align to allow for a smooth ride.

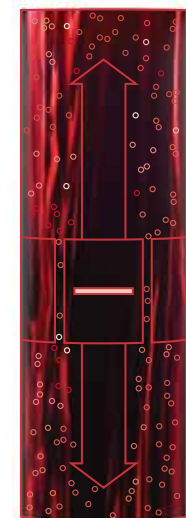

Controlled
During cornering or on uneven surfaces, a magnetic field realigns the particles for a more secure, precise driving experience.

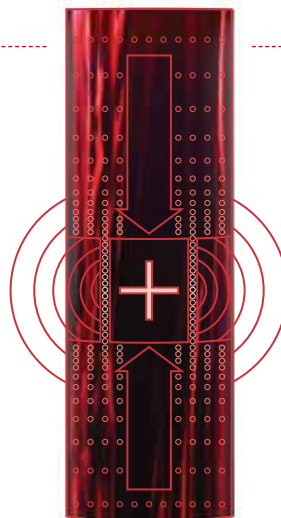

¹Excludes other GM vehicles.



Electric Rack-and-Pinion Steering The electric variable-assist power rack-and-pinion steering system on Sierra provides precise handling.

Hydroformed Frame Providing Sierra with the ultimate in a solid foundation is a hydroformed, fully boxed, high-strength steel frame.

Corrosion-Resistant Duralife Brake Rotors GMC engineers used patented Ferritic Nitro-Carburizing (FNC) technology that can help double rotor life.

High Lateral-Rate Body Mounts Connecting the body to the frame are high lateral-rate hydraulic and shear-style body mounts for a smooth, quiet ride.

Coil-Over-Shock Front Suspension This fully independent system is precisely tuned for improved handling.

Large Ring Gears On Sierra models with the available 5.3L V-8 engine, the rear axle features a large (9.5") ring gear. Choose the Max Trailering Package or an available 6.2L model and it increases to 9.76." The rear axles are engineered to handle the robust power and provide durability.

Eaton® Automatic Locking Rear Differential This available feature automatically directs power to the wheel with the most traction on loose gravel or slippery surfaces to keep Sierra moving confidently forward.

StabiliTrak Sierra's electronic stability control system helps improve stability by detecting and reducing traction loss.

IT'S NOT JUST HOW MUCH YOU TOW. IT'S HOW WELL YOU TOW.

Sierra is equipped with the available 6.2L V-8 and Max Trailering Package to confidently tow up to 12,500 lbs.¹ Its power and seamlessly integrated trailering technologies keep you firmly in command of heavy loads, even in challenging situations.

NHT Max Trailering Package (Available) Increased trailering capacity results when Sierra is equipped with this available package. It includes a 9.76" ring gear, 3.73 (6-speed) or 3.42 (8-speed) axle ratio with the available 5.3L V-8 (3.42 with 6.2L V-8), trailer brake controller, enhanced cooling radiator, revised shock tuning and heavier-duty rear springs.

Premium Trailering Mirrors The mirrors are heated and power-adjustable and are required and only available with the Max Trailering Package. On SLT models, the mirrors include a power-folding feature and driver memory. You'll appreciate the segment-first LED rear guidance lamps that enhance visibility when backing up.

Hill Start Assist Sensors automatically detect when Sierra is on a 5 percent grade or more. The system holds the brakes momentarily or until the accelerator is pressed, preventing rollback.

Tow/Haul Mode To give you even more power to accelerate when trailering or hauling heavy loads, Tow/Haul mode raises transmission upshift points.

Rear Vision Camera System The center screen serves as your monitor for the camera. Its dynamic grid lines help when hitching a trailer.

Trailering Camera System This available dealer-installed accessory system,² produced by EchoMaster,[®] provides several vantage points for confident trailering. Integrated into Sierra's center screen, the system offers multiple simultaneous views around Sierra. See your dealer for complete details.

Trailer Sway Control This technology keeps both your Sierra and your trailer heading in the same direction, automatically. It detects a swaying trailer and applies both the vehicle's and the trailer's brakes (if properly equipped) to help bring it back in line.

Trailer Brake Controller For fingertip control and easy monitoring of your trailer brakes, Sierra offers an available integrated trailer brake controller. It displays the level of brake force or "gain" in the Driver Information Center (DIC).

Auto Grade Braking When going downhill, it automatically senses when you want to slow your Sierra and engages a Grade Braking shift pattern to help maintain your desired speed.

TapShift For full command over Sierra's shifting, TapShift controls on the gear lever use a precise algorithm that improves shifting response time.

Transmission Temperature Gauge Located in the DIC, it allows you to monitor the transmission fluid operating temperature in real time.



SIERRA CREW CAB SHORT BOX IN RED QUARTZ TINTCOAT shown with available equipment.

¹Sierra's 7,600-lb rating requires Sierra Regular Cab Standard Box 4WD with 4.3L EcoTec3 V-6 engine. Sierra's 12,500-lb rating requires Sierra Double Cab or Crew Cab Short Box 2WD with 6.2L EcoTec3 V-8 engine and Max Trailering Package. Sierra's 11,100-lb rating requires Sierra Double Cab 2WD with 5.3L EcoTec3 V-8 engine and Max Trailering Package. Before you buy a vehicle or use it for trailering, carefully review the trailering section of the Owner's Manual. The weight of passengers, cargo and options or accessories may reduce the amount you can tow. ²The IntelliHaul Trailering Camera System is an Associated Accessory sourced from EchoMaster, an independent supplier, and is not warranted by GM or its dealers. GM is not responsible for the safety or quality of third-party supplier alterations. EchoMaster provides a 3-year/36,000-mile manufacturer's warranty. For details on the warranty provided by EchoMaster (Power Brand of AAMP Global), please call 866-766-2267.

7,600 LBS

4.3L V-6

With the standard 4.3L V-6, Sierra achieves a maximum trailer weight rating of up to 7,600 lbs when properly equipped.¹

11,100 LBS

5.3L V-8

Choose the available 5.3L V-8 with the Max Trailering Package and you're able to tow up to a maximum of 11,100 lbs when properly equipped.¹

12,500 LBS

6.2L V-8

Select the available 6.2L V-8 with the available Max Trailering Package and pull even bigger work or play equipment—up to a maximum of 12,500 lbs when properly equipped.¹

FOUR DOORS. SEVERAL CHOICES.

Our designers and engineers work well together. So they combined their skills to create three distinct four-door cab and bed options for the 2018 Sierra. Whether you choose the Crew Cab Short Box, Crew Cab Standard Box or the Double Cab Standard Box, they all provide up to six-passenger seating and easy access with the addition of traditional forward-hinged rear doors.



SIERRA SLE DOUBLE CAB IN DARK SLATE METALLIC WITH STANDARD BOX (left)
SIERRA SLE CREW CAB IN RED QUARTZ TINTCOAT WITH STANDARD BOX (right)
Vehicles shown with available equipment.

Double Cab Standard Box The Sierra Double Cab features forward-hinged rear doors to make it easier to get into and out of the rear seats. Once inside, passengers will benefit from 34.6" of leg room. (Double Cab models come with a 6' 6" Standard Box.)

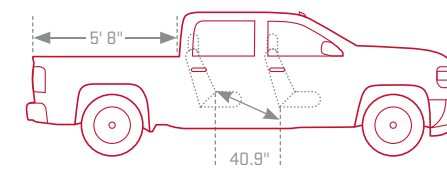
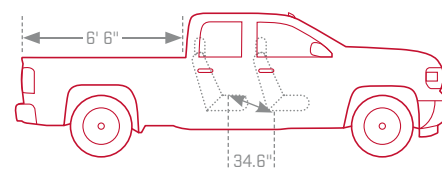

Crew Cab Short Box or Standard Box The Sierra Crew Cab, with 40.9" of generous rear-seat leg room, makes for comfortable companions. The doors and the second-row openings are large to accommodate unobstructed entry and exit. Crew Cab models come with a 5' 8" Short Box (left) or an available 6' 6" Standard Box (right).

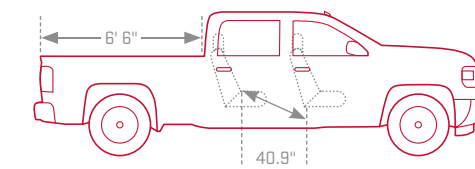



FUNCTIONALITY

EVERY ELEMENT IN EVERY GMC GOES BEYOND ITS BOLD, CONFIDENT APPEARANCE.
EACH SERVES A HIGHER PURPOSE—WHERE SIERRA'S FORM IS EXCEEDED ONLY BY ITS FUNCTION.

ANATOMY OF COMFORT

Sierra achieves the ultimate in support and comfort. Its seats are engineered to feel good from day one and for the long haul. Add available leather appointments and heating and ventilation, and leaving the seats may not be easy.

Lasting Comfort Seats Hard work shouldn't describe the front seats in your Sierra. That's precisely why they feature a bolstered design to support you and dual-firmness foam to provide lasting comfort. We used generous seat cushion bolsters so they'll maintain their shape and appearance over time. A premium grade of foam was selected for its ability to retain its shape and reduce driver and passenger fatigue. The seats also use high-wear materials that were tested for 100,000 durability cycles of entry and exit.

Heated and Ventilated Front Seats The ultimate in all-weather comfort, these seats (standard on Denali; available on SLT) are perforated and leather appointed. You'll also appreciate the warmth of front heated leather-appointed seats on SLT or available front heated cloth seats on SLE.

Power Front Seats Get comfortable at the touch of a button with available power-adjustable front seats. Driver-seat adjustment is available for 40/20/40 seating with select equipment packages, and power driver and front-passenger seats are included with all bucket seats on SLE (10-way driver/six-way passenger), SLT (10-way driver/10-way passenger) and Denali (12-way driver/12-way passenger).



Premium Materials Sierra offers premium materials such as a soft-touch feel on the instrument panel, while real aluminum trim and contrasting stitching give the interior an overall refined appearance.



Generous Storage An available center floor console maximizes space with a cavernous storage bin large enough for hanging files, a laptop or mobile devices. Pockets on either side of the console and in the door panels offer "grab and go" convenience and twin glove boxes give you and your companions personal storage areas.



Heated Steering Wheel Standard on Denali and available on SLT, the leather-wrapped, heated steering wheel adds warmth whenever you demand it.



Rear Seating Rear-seat comfort is the result of 40.9" of leg room on Crew Cabs. The Rear-Seat Reminder (standard on Double Cab and Crew Cab models) is activated when a second-row door is opened or closed during or just before a trip. When Sierra is turned off, under certain conditions, an audible chime and a message in the Driver Information Center remind you to check the second row.¹



Climate Control Automatic dual-zone climate control with individual settings for the driver and front-seat passenger is standard on SLT and Denali and available on SLE.



Power-Adjustable Pedals To help drivers of varying heights sit at a comfortable distance from the steering wheel, adjustable pedals are available on SLE and standard on SLT and Denali.

¹Does not detect people or items. Always check the rear seat before exiting the vehicle.



SIERRA DENALI CREW CAB INTERIOR IN JET BLACK shown with available equipment.

INFORMATION. MORE POWERFUL.

Sierra's ergonomically configured instrument panel places information where it's quickly visible and controls where they're easily under your command. In Sierra Denali, the GMC Infotainment System,¹ full-color 8" diagonal touch-screen and Apple CarPlay™ and Android Auto compatibility² provide immediate data and dynamic response. An 8" diagonal Customizable Driver Display in the gauge cluster lets you personalize vital information with selectable themes—Standard, Technology and Media. Knobs and buttons are large to accommodate gloved hands, while gauges are easy to read and LED back-lit.

- + Up to Six USB Ports³ Throughout the Cabin
- + 4G Wi-Fi Hotspot⁴ (Available)
- + Bluetooth⁵ Connectivity (Available)
- + 110-Volt Power Outlet (Available)

¹Full functionality requires compatible Bluetooth and smartphone. Some devices require USB connectivity. Data plan rates apply. ²Vehicle user interfaces are products of Apple® and Google and their terms and privacy statements apply. Requires compatible smartphone. Data plan rates apply. ³Not compatible with all devices. ⁴Requires a compatible mobile device, active OnStar service and data plan. 4G service available in select markets. Visit onstar.com for coverage map, details and system limitations. Data plan provided by AT&T. ⁵Go to my.gmc.com/learn to find out which phones are compatible with the vehicle.

CORNER OFFICE. HOME OFFICE. MOBILE OFFICE.

You can always count on Sierra to offer advanced technologies to keep you connected, entertained and highly productive. Stay connected on the go with the available built-in Wi-Fi hotspot¹ to make Sierra your office away from the office.



4G Wi-Fi Hotspot¹ Available 4G built-in Wi-Fi means a fast internet connection for up to seven web-enabled devices. It's reliable, easy to use and can connect up to 50 feet around the vehicle when it is running. Visit onstar.com for details.

GMC Infotainment System² The system features a full-color 7" or an available 8" diagonal screen for easy viewing and hands-free, voice-activated control of your smartphone. Stream music, sync MP3 music, receive vocalized text messages, benefit from Siri[®] Eyes Free³ assistance, connect libraries from multiple devices and store phone contacts.



Bose Audio System The optional Bose audio system is engineered to give you the realism and presence of a live performance.



Rear Vision Camera System The center screen also serves as your monitor for the camera. Its dynamic grid lines (included on all 7" and 8" diagonal screens) help provide the perfect target when backing up or hitching a trailer.

Center Console Wireless Charging⁴ Available wireless charging located on the center console lets you power up your compatible phone or device anytime the vehicle is running. Plus, you'll also find up to six available USB ports,⁵ four auxiliary power outlets and an available 110-volt outlet to keep everyone connected and powered up.



Voice And Touch-Screen Navigation⁶ In response to your voice or touch, Sierra's available Navigation System displays 2-D or 3-D map graphics on the 8" diagonal center-mounted screen. Also included, NavTraffic⁷ (with 3 trial months of SiriusXM) incorporates real-time traffic and road conditions, directing you toward the most efficient route.

¹Requires a compatible mobile device, active OnStar service and data plan. 4G service available in select markets. Visit onstar.com for coverage map, details and system limitations. Data plan provided by AT&T. ²Full functionality requires compatible Bluetooth and smartphone. Some devices require USB connectivity. Data plan rates apply. ³Requires GMC Infotainment System and compatible iPhone[®] running iOS 6 or newer. ⁴The system wirelessly charges one PMA- or Qi-compatible mobile device. Some devices require an adapter or back cover. To check for phone or other device compatibility, visit my.gmc.com/learn for details. ⁵Not compatible with all devices. ⁶Map coverage available in the United States, Puerto Rico and Canada. ⁷If you decide to continue service after your trial, the subscription plan you choose will automatically renew thereafter and you will be charged according to your chosen payment method at then-current rates. Fees and taxes apply. To cancel, you must call SiriusXM at 1-866-635-2349. See SiriusXM Customer Agreement for complete terms at siriusxm.com. All fees and programming subject to change. For more information about NavTraffic, visit siriusxm.com/navtraffic. For more information about Travel Link, visit siriusxm.com/travellink. Sirius, XM, SiriusXM and all related marks and logos are trademarks of SiriusXM Radio, Inc.

SEE. AND BE SEEN.

To help give Sierra clear vision in many driving situations, GMC engineers use available high-performance LED headlamps, thin-profile LED fog lamps and LED taillamps to provide visibility, efficiency and durability.

- + IntelliBeam Automatic Hi-Beam On/Off Headlamps (Available)
- + High-Performance Projector-Beam LED Headlamps (Available)
- + Thin-Profile LED Fog Lamps (Available)





THERE ARE PREMIUM ACCOMMODATIONS BACK HERE, TOO

Our most innovative cargo box ever helps you access, load and secure cargo, all while protecting the bed.

Tri-Mode Power Steps Sierra Denali offers power assist steps that automatically extend when the front- or second-row doors are opened to provide easy access. They retract when the doors close for an uncluttered profile. Tap a button on the edge of the step with your foot and it moves rearward for side access into the bed. See your dealer for more availability details.

Remote Power-Locking Tailgate This available convenience allows you to lock or unlock the tailgate from the key fob.

CornerStep Rear Bumper and Integrated Handgrips Crafted into the corners, the bumper steps make it easy to access the cargo box. The depth of the step accommodates large boots, and ergonomically designed handgrips on the top of the side rails help give you a boost into the bed.

EZ-Lift and Lower Tailgate Loading the cargo box takes less effort thanks to an available EZ-Lift and Lower Tailgate. It also keeps the tailgate from slamming down.

LED Under-Rail Lights Available LED lights are conveniently positioned under each cargo box rail to make it easier to load or unload at night, or when the box is enclosed by a tonneau cover.

Spray-On Bedliner To provide a permanent, durable nonskid surface, the available (standard on Denali and All Terrain) black liner covers the entire bed below the side rails, including the tailgate, front box top rail and lower tie-down hooks. It's designed to protect Sierra's premium fit and finish.

Eight Tie-Down Hooks In addition to four lower stationary hooks are four patented, load-bearing movable upper hooks. Rated at 250 pounds¹ each, the upper hooks can be repositioned in several places around the box depending on the cargo being secured.

Bed Rail Protection Simple yet all-too-important elements like standard rail protectors at the top of the box improve damage resistance. And to help reduce turbulence, a rear spoiler is integrated into the top of the tailgate.

High-Strength Steel Bed Unlike the stamped-steel process, a roll-formed process is used in Sierra's cargo bed floor to allow for a higher-grade steel that's stronger, lighter and more durable. Sierra offers a maximum payload of more than a ton² (up to 2,250 pounds on 2WD Double Cab with the available Max Trailering Package and 5.3L V-8).



CornerStep rear bumper and integrated handgrips



Tie-down hooks

¹Cargo and load capacity limited by weight and distribution. ²These maximum payload ratings are intended for comparison purposes only. Before you buy a vehicle or use it to haul people or cargo, carefully review the vehicle loading section of the Owner's Manual and check the carrying capacity of your specific vehicle on the label on the inside of the driver's door jamb.

CARRY YOUR OWN SECURITY DETAIL



Rear Park Assist This available feature alerts you to objects behind the truck.

Rear Vision Camera System The center screen serves as a helpful monitor for the rear-vision camera. It helps you see what's behind you when backing up.

LATCH Child-Seat Anchoring System LATCH stands for Lower Anchors and Tethers for CHildren. A child seat with LATCH attachments installs to specially designed anchors with an audible "click." You can also install a top tether strap (if child seat is equipped) that helps limit forward movement and child-seat rotation while driving or in a crash.

Safety Alert Seat Relaying inputs from available features such as Forward Collision Alert and Lane Keep Assist with Lane Departure Warning, this available seat alerts you to potential traffic danger using directional vibration pulses within the seat cushion instead of audible alerts.

Lane Keep Assist With Lane Departure Warning This available feature helps drivers avoid crashes due to unintentional lane changes. It assists by gently turning the steering wheel if Sierra approaches a detected lane marking without the turn signal being activated.

Enhanced Driver Alert Package This available package provides the reassurance of Lane Keep Assist with Lane Departure Warning, Forward Collision Alert, Front and Rear Park Assist, Safety Alert Seat, IntelliBeam headlamps and Low Speed Forward Automatic Braking.

Front Park Assist This available feature alerts you to objects in front of the truck while parking.

Low Speed Forward Automatic Braking If the vehicle is traveling at a low speed and the available system detects that a front-end collision situation is imminent while following a detected vehicle, and you have not applied the brakes, the system automatically applies the brakes to help reduce the collision's severity. The system may even help you to avoid the collision at very low speeds.

Reinforced Steel Safety Cage Design Sierra's body structure is engineered to help maintain the integrity of the passenger compartment in the event of a collision.

Air Bags¹ To help reduce the risk of injury to passengers, dual-stage frontal air bags use sensors to gauge the severity of a crash. Head-curtain air bags deploy from the roof rail to provide protection for outboard passengers and can be activated by either rollover or side-impact sensors.

Safety features are no substitute for the driver's responsibility to operate the vehicle in a safe manner. The driver should remain attentive to traffic, surroundings and road conditions at all times. Read the vehicle Owner's Manual for important feature limitations and information.

¹A NOTE ON CHILD SAFETY: Always use safety belts and the correct child restraint for your child's age and size, even with air bags. Even in vehicles equipped with the Passenger Sensing System, children are safer when properly secured in a rear seat in the appropriate infant, child or booster seat. Never place a rear-facing infant restraint in the front seat of any vehicle equipped with an active frontal air bag. See your vehicle Owner's Manual and child safety seat instructions for more safety information.

PRECISION-CRAFTED RIGHT DOWN TO THE WHEELS

Building the 2018 Sierra means crafting every inch of it from the ground up—especially the wheels it rides on. That's why you'll find a selection of specially designed GMC wheels in a range of styles for your Sierra. See your dealer for more wheel availability details.

17" Painted Steel (RD6)
Standard on Sierra



17" Stainless-Steel Clad (RD7)
Available on Sierra Regular Cab and Double Cab with Sierra Appearance Package



17" Painted and Bright Machined Aluminum (Q5W)
Available on Sierra Crew Cab with Sierra Appearance Package. Standard on SLE.



20" Black Painted Aluminum (NZO)
Included with Elevation Edition models only



18" Bright Machined Aluminum (UHN)
Included on SLE and SLT with Z71 Off-Road Suspension Package, Max Trailering Package and SLT All Terrain



18" 5-Spoke Black Painted Aluminum (REG)
Included with All Terrain X only



20" Bright Machined Aluminum (RD3)
Available on Elevation Edition models, SLE and SLE with Z71 Off-Road Suspension Package or Max Trailering Package



18" Polished Aluminum (RCW)
Standard on SLT



20" Bright Machined Aluminum With Dark Argent Painted Accents (NZH)
Available on SLT All Terrain only



20" Chrome-Clad Aluminum (NZP)
Available on SLT with SLT Crew Cab Premium "Plus" Package



20" Polished Aluminum (RD5)
Available on SLT with SLT Premium Package



20" Ultra-Bright Machined Aluminum (NZG)
Standard on Denali



20" Chrome Aluminum (RTL)
Available on Denali



22" Aluminum With Premium Paint and Chrome Inserts (Q7M)
Included with Denali Ultimate Package only



WE SIGNED OUR WORK. NOW IT'S YOUR TURN.

GMC Accessories range from the functional to the stylish so you can truly make Sierra your own.



SF0 Accessory Wheel¹
22" 6 split-spoke
Ultra-Bright Machined
Manooagian Silver



SEW Accessory Wheel¹
22" 5 split-spoke
Ultra-Bright Machined
High-Gloss Black



SEV Accessory Wheel¹
22" 6-spoke
High-Gloss Black



RXN Accessory Wheel¹
22" 7-spoke Aluminum
with Chrome Inserts



RX1 Accessory Wheel¹
22" 7-spoke Silver with
Black Inserts



Performance Cat-Back Exhaust A GMC-engineered stainless steel cat-back performance exhaust system delivers both increased horsepower and a bold exhaust note. Available with the 5.3L V-8 engine only. See your dealer for details.



Premium Floor Liners Sierra's floor liners take all-weather floor mat coverage further with raised edges to help protect floor and trim contours.



Tonneau Covers The soft cover shields cargo, easily rolls up to allow full access to the bed and is constructed with integrated crossbows. A soft tri-fold cover is also available. The hard cover is tri-folding and adds strong content protection and easy access to the cargo box. All three covers display a GMC logo.



Molded Splash Guards Custom-designed molded splash guards fit directly behind the wheels to help protect against tire splash and mud. Specially designed for your vehicle, they include styling features that accent the exterior of your Sierra.



Rear Under-Seat Storage Organizer Contain, organize and conceal items under the rear seat of your Sierra with this durable, molded plastic under-seat storage box. Shown with second-row floor liners.



Assist Steps Make it easier to get into and out of your truck with these stylish steps. The 6" rectangular are chrome (shown) and the 4" round are stainless steel. Both are rust-resistant and available in either chrome or black powder coat.

¹Use only GM-approved tire and wheel combinations. Unapproved combinations may change the vehicle's performance characteristics. For approved tire and wheel combinations and other important information, go to gmcaccessories.com or see your dealer for details.

INSTRUMENT PANEL ACCENTS



Axiom Aluminum Burnished Aluminum Dark Aluminum

DOOR AND CONSOLE ACCENTS

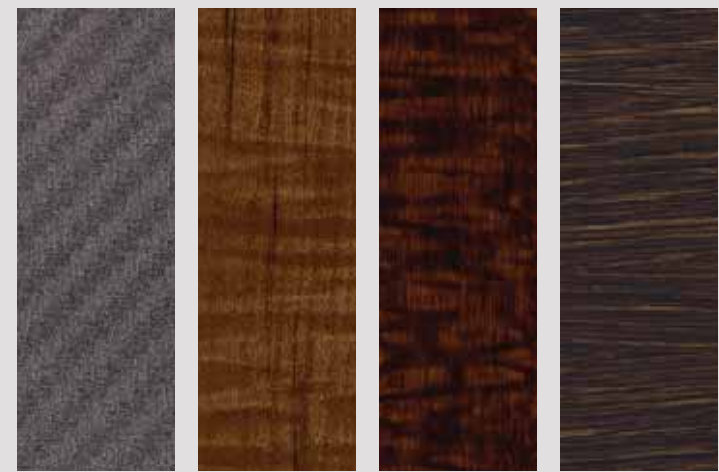

Off-Road Carbon Accent Mineral Caster Wood Tone Grand Lace Wood Tone Oblique Hanon Oak Wood Tone

**INTERIOR COLORS/
SEATING SURFACES**

VINYL

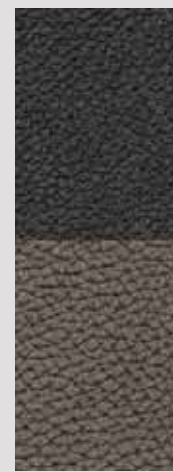

Jet Black/Dark Ash Vinyl

CLOTH

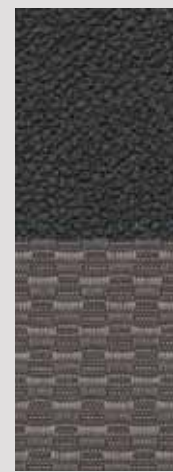

Jet Black/Dark Ash Cloth

LEATHER APPOINTMENTS

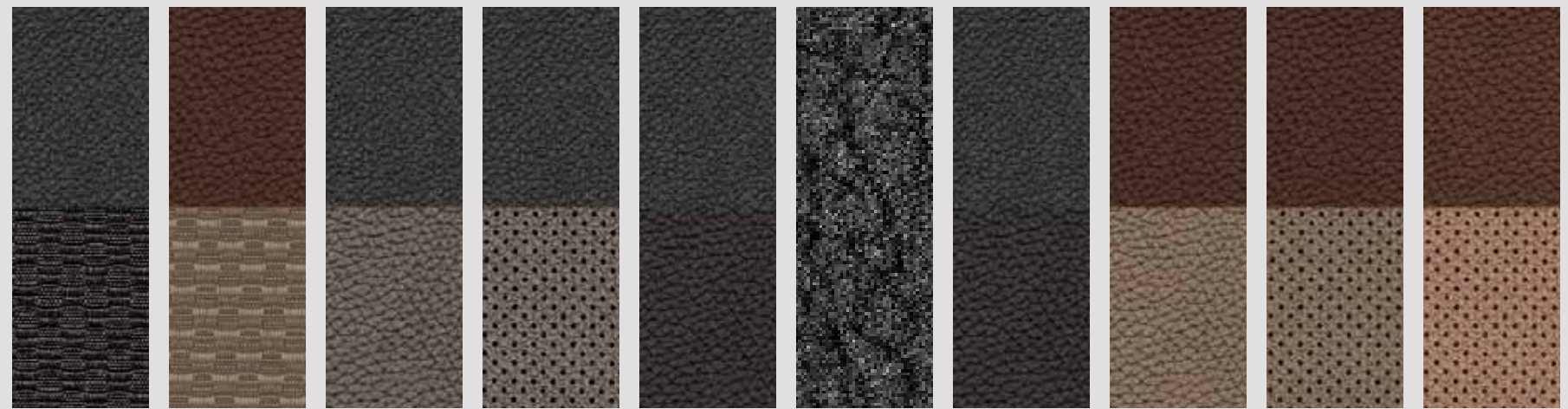

Jet Black/Jet Black Cloth Cocoa/Dune Cloth Jet Black/Dark Ash Leather-Appointed Jet Black/Dark Ash Perforated Leather-Appointed Jet Black/Jet Black Leather-Appointed Jet Black/Jet Black Perforated Leather-Appointed Jet Black/Jet Black Leather-Appointed with Spice Red Accents Cocoa/Dune Leather-Appointed Cocoa/Dune Perforated Leather-Appointed Cocoa/Dark Sand Perforated Leather-Appointed

MODELS

SIERRA	—	—	—	—	—	—	○	●	—	—	—	—	—	—	—	—	—	—	—
ELEVATION EDITION	—	—	—	—	—	—	—	●	—	—	—	—	—	—	—	—	—	—	—
SLE	●	—	—	—	● ¹	● ²	—	●	—	—	—	—	—	—	—	—	—	—	—
ELEVATION EDITION SLE	●	—	—	—	● ¹	● ²	—	●	—	—	—	—	—	—	—	—	—	—	—
SLT	●	—	—	—	● ¹	● ²	—	—	—	●	○	●	○	—	●	○	—	—	—
ALL TERRAIN	—	—	●	●	—	—	—	—	—	—	—	—	—	●	—	—	—	—	—
DENALI	—	●	—	—	—	—	●	—	—	—	—	—	● ³	—	—	—	—	—	● ³

KEY ● STANDARD ○ AVAILABLE — NOT AVAILABLE

EXTERIOR COLORS (See your GMC dealer for more exterior color details)



¹Included with Cocoa/Dune interior color only. ²Included with Jet Black and Jet Black/Dark Ash interiors only. ³Includes unique Denali accents. ⁴Additional charge, premium paint. ⁵Not available on Denali. ⁶Not available with All Terrain or All Terrain X. ⁷Denali only. ⁸Not available on Crew Cab models. ⁹Not available on Sierra trim. ¹⁰Crew Cab models only.

SIERRA 1500 SPECIFICATIONS

EXTERIOR DIMENSIONS	REGULAR CAB	DOUBLE CAB	CREW CAB
Height (in.)	73.5-74.1	73.9	73.7-74.2
Overall Length (in.)			
Short Box (in.)	—	—	229.3
Standard Box (in.)	205.0	229.4	238.9
Long Box (in.)	224.4	—	—

INTERIOR DIMENSIONS	REGULAR CAB	DOUBLE CAB	CREW CAB
Head Room, Front/Rear (in.)	42.4/—	42.8/38.7	42.8/40.5
Shoulder Room, Front/Rear (in.)	66.0/—	65.9/65.8	66.0/65.7
Leg Room, Front/Rear (in.)	45.3/—	45.3/34.6	45.3/40.9

WHEELBASE	REGULAR CAB	DOUBLE CAB	CREW CAB
Short Box (in.)	—	—	143.5
Standard Box (in.)	119.0	143.5	153.0
Long Box (in.)	133.0	—	—

CARGO DIMENSIONS ¹	SHORT BOX	STANDARD BOX	LONG BOX
Cargo Volume	53.4 cu. ft.	61.0 cu. ft.	76.3 cu. ft.
Inside Width at Floor (in.)	51.0	51.0	51.0
Box Length at Floor (in.)	69.3	78.9	97.8

STANDARD TECHNICAL DATA

Series/Drive Type	1500/2WD	1500/4WD
BRAKES All models: Power 4-wheel antilock braking system	Front disc/rear disc (w/Duralife rotors)	Front disc/rear disc (w/Duralife rotors)
STEERING	Electric power rack-and-pinion with variable assist	Electric power rack-and-pinion with variable assist
FUEL TANK CAPACITY (Approx. gals.: Short/Standard/Long Box)	26.0/26.0/34.0	26.0/26.0/34.0
ALTERNATOR (amps)	150	150

GVWR² (Gross Vehicle Weight Rating, lbs)

Regular Cab	6,500-6,800	6,700-7,000
Double Cab	6,900-7,400	7,100-7,600
Crew Cab	6,900-7,400	7,100-7,600

ENGINES

	4.3L EcoTec3 V-6 VVT DI AFM/Aluminum Block (LV3)	5.3L EcoTec3 V-8 VVT DI AFM/Aluminum Block (L83)	5.3L EcoTec3 V-8 VVT DI with eAssist AFM (L8B)	6.2L EcoTec3 V-8 VVT DI AFM/Aluminum Block (L86)
CAPACITY	4.3 liters (262 cu. in.)	5.3 liters (325 cu. in.)	5.3 liters (325 cu. in.)	6.2 liters (376 cu. in.)
SAE NET HORSEPOWER @ RPM	285@5,300	355@5,600	355@5,600	420@5,600
SAE NET TORQUE @ RPM (LB-FT)	305@3,900	383@4,100	383@4,100	460@4,100

ENGINE/MODEL AVAILABILITY

Regular Cab, Standard Box	●	○	—	—
Regular Cab, Long Box	●	○	—	—
Double Cab, Standard Box	●	○	—	○
Crew Cab, Short Box	●	○	○	○
Crew Cab, Standard Box	—	●	—	○

FUEL ECONOMY (city/hwy mpg)

2WD 6-speed auto (EPA est.)	18/24	16/23	—	—
2WD 8-speed auto (EPA est.)	—	16/22	18/24	15/21
4WD 6-speed auto (EPA est.)	17/22	16/22	—	—
4WD 8-speed auto (EPA est.)	—	15/20	16/21	15/20

E85 FLEXFUEL CAPABLE³

TRANSMISSION	1500: Electronically controlled 6-speed automatic transmission with overdrive, electronic engine grade braking and Tow/Haul mode
	1500: Electronically controlled 8-speed automatic transmission with overdrive, electronic engine grade braking and Tow/Haul mode (Requires L86 6.2L V-8 on Double Cab models. On Crew Cab models, included and only available with All Terrain Package, SLT Crew Cab Premium "Plus" Package, SLT with Max Trailering Package, L86 6.2L V-8 or Denali trim.)
	1500: Electronically controlled 8-speed automatic eAssist transmission with overdrive, electronic engine grade braking and Tow/Haul mode (Requires L8B 5.3L V-8 and Crew Cab models with SLT eAssist Package.)

SIERRA 1500 SUSPENSIONS⁴

FRONT SUSPENSION COIL-OVER-SHOCK

FRONT AXLE/SPRING CAPACITY (lbs)	2WD (Short/Standard/Long Box)	4WD
Regular Cab	—/3,300/3,300	—/3,950/3,950
Double Cab	—/3,850/—	—/3,950/—
Crew Cab	3,850/—/—	3,950/3,950/—

REAR SUSPENSION SEMI-ELLIPTICAL 2-STAGE MULTILEAF SPRINGS

REAR AXLE/SPRING CAPACITY (lbs)	2WD (Short/Standard/Long Box)	4WD
Regular Cab	—/3,800/3,950	—/3,850/3,950
Double Cab	—/3,950/—	—/3,950/—
Double Cab w/Max Trailering Package	—/4,300/—	—/4,300/—
Crew Cab	3,950/—/—	3,950/3,950/—
Crew Cab w/Max Trailering Package	4,300/—/—	4,300/4,300/—

KEY ● STANDARD ○ AVAILABLE — NOT AVAILABLE

¹Cargo and load capacity limited by weight and distribution. ²When properly equipped; includes weight of vehicle, passengers, cargo and equipment. ³When running on E85, Sierra 1500 2WD offers an EPA-estimated 12 city/16 hwy mpg with the 4.3L V-6 and 12 city/17 hwy mpg with the 5.3L V-8. E85 FlexFuel capability is not available in AZ, CA, CT, DE, MA, MD, ME, NJ, NY, OR, PA, RI, VT and WA. E85 is a combination of 85% ethanol and 15% gasoline. Go to afdc.energy.gov/afdc/fuels to see if there is an E85 fuel station near you. ⁴Capacities and weight ratings are dependent on model, engine, transmission and GVWR combinations. See your GMC dealer for details.

SEATING

	SIERRA ELEVATION EDITION	SLE	ELEVATION EDITION SLE	SLT	ALL TERRAIN	DENALI
SEATS Front 3-passenger cloth 40/20/40 split bench with driver and front-passenger manual recline, manual driver lumbar control and outboard head restraints. Includes center fold-down armrest with storage.	●	●	—	—	—	—
Front 3-passenger vinyl 40/20/40 split bench with driver and front-passenger manual recline and outboard head restraints. Includes center fold-down armrest with storage.	○	—	—	—	—	—
Front 3-passenger cloth 40/20/40 split bench with driver and front-passenger manual recline and outboard head restraints. Includes center fold-down armrest and lockable storage compartment in lower seat cushion.	—	—	●	●	—	—
Front cloth bucket seats with 10-way driver-seat power adjuster, 6-way passenger-seat power adjuster, heated seat cushions and seatbacks, adjustable head restraints, floor console and storage pockets. Not available on Regular Cab model.	—	—	○	○	—	—
Front 3-passenger leather-appointed 40/20/40 split bench with 10-way power seat adjusters. Includes power lumbar control, heated seat cushions and seatbacks, 2-position driver memory (does not apply to lumbar adjuster) and adjustable head restraints.	—	—	—	—	●	—
Front leather-appointed bucket seats with 10-way power seat adjusters including power lumbar control, heated seat cushions and seatbacks, 2-position driver memory (does not apply to lumbar adjuster), adjustable head restraints and floor console and storage pockets	—	—	—	○	●	—
Seat adjuster, driver 10-way power. Requires bench seat. Included and only available with SLE Value Package.	—	—	○	●	—	—
Heated driver and front-passenger cloth seating. Requires SLE Value Package and cloth 40/20/40 split bench seat. Not available on Regular Cab models.	—	—	○	○	—	—
Heated and ventilated perforated leather-appointed front bucket seats. Included with Enhanced Driver Alert Package. Not available with All Terrain Package. On Denali, includes embroidered Denali logo on front seats and 12-way driver and front-passenger power adjuster, including 4-way power lumbar control.	—	—	—	○	—	●
Folding rear 60/40 split 3-passenger bench. Includes child seat top tether anchor. On Sierra trim Double Cab model, includes folding rear 3-passenger bench. Double and Crew Cab models only.	●	●	●	●	●	●

INTERIOR DETAILS

CLIMATE CONTROL Single-zone manual air conditioning	●	●	●	—	—	—
Dual-zone automatic climate control. On SLE, included and only available with SLE Value Package. Not available on Regular Cab models.	—	—	○	●	●	●
CRUISE CONTROL Steering-wheel-mounted	●	●	●	●	●	●
DOOR LOCKS Power	●	●	●	●	●	●
FLOOR COVERING Graphite-colored rubberized vinyl	●	—	—	—	—	—
Color-keyed carpeting with rubberized vinyl floor mats. (Double and Crew Cab models include second-row floor mats.)	○	●	●	●	—	—
Color-keyed carpeting with color-keyed carpeted first- and second-row floor mats	—	—	—	—	●	●
All-weather floor liners. Dealer-installed.	○	○	○	○	○	○
NOISE CONTROL SYSTEM Active noise cancellation. Included and only available with 6.2L V-8 engine.	—	—	—	○	○	○
REMOTE VEHICLE STARTER SYSTEM On SLE, included and only available with SLE Preferred Package or SLE Value Package	—	—	○	●	●	●
REMOTE KEYLESS ENTRY Included with Convenience Package on Sierra trim. Includes remote locking tailgate.	○	●	●	●	●	●
REARVIEW MIRROR With manual day/night adjustment	●	●	●	●	—	—
With inside rearview auto-dimming feature. On Sierra and SLE trim, included and only available with black, heated power trailer mirrors.	○	—	○	—	●	●
SILL PLATES Bright. Front only on Double Cab All Terrain model.	—	—	—	—	●	●
SUNROOF Power sliding with express-open. Crew Cab models only.	—	—	—	○	○	○

UNIVERSAL HOME REMOTE On SLE, included and only available with SLE Value Package. Not available on Regular Cab models.

WINDOWS Power with driver express-up and -down and express-down on all other windows. Standard on all Double and Crew Cab models. On Sierra Regular Cab, included and only available with Sierra Convenience Package.

Power rear sliding with rear defogger. On SLE, included and only available with SLE Convenience Package. On SLT, included and only available with SLT Preferred Package or SLT Crew Cab Premium "Plus" Package. On All Terrain, included and only available with All Terrain Premium Package. Not available on Regular Cab models.

WIRELESS CHARGING MAT¹ Center console-mounted. Included and only available with front bucket seats. Not compatible with all phones.

OPTION PACKAGES

ALL TERRAIN X PACKAGE Available on Crew Cab and Double Cab All Terrain 4WD models. Includes performance exhaust system (only on 5.3L V-8), 18" black painted wheels, 18" Goodyear® Wrangler DuraTrac® 265/65R18 SL 114S blackwall MT tires, high-performance LED headlamps, black Sport Assist Step, black bed-mounted tubular sport bar and B-pillar vinyl wrap.

ALL TERRAIN PREMIUM PACKAGE Available on Crew Cab and Double Cab All Terrain models. Includes NZH 20" machined aluminum wheels with painted accents, Front and Rear Park Assist, high-performance LED headlamps, 4" black round assist steps, heated steering wheel and power-sliding rear window. Not available with All Terrain X Package.

SIERRA APPEARANCE PACKAGE Includes RD7 17" stainless-steel-clad wheels and deep-tint glass. On Crew Cab models, RD7 17" wheels are replaced with Q5W 17" painted and bright machined aluminum wheels.

SIERRA CONVENIENCE PACKAGE Includes exterior heated power-adjustable mirrors, remote keyless entry, 110-volt AC power outlet, remote locking tailgate and LED cargo box lighting. Includes power windows on Regular Cab models.

DENALI ULTIMATE PACKAGE Requires 4WD model. Includes 6.2L EcoTec3 V-8, 22" aluminum wheels with premium paint and chrome inserts (Q7M), power sunroof, integrated trailer brake controller, tri-mode power steps and chrome recovery hooks.

ENHANCED DRIVER ALERT PACKAGE Includes Lane Keep Assist with Lane Departure Warning, Forward Collision Alert, IntelliBeam headlamps, Front and Rear Park Assist, Low Speed Forward Automatic Braking and Safety Alert Seat. On SLT, requires SLT Preferred Package. Includes heated and ventilated driver and passenger front bucket seats. On SLE, requires Regular Cab model, SLE Preferred Package, Jet Black cloth interior trim and driver 10-way power seat adjuster.

SLE CONVENIENCE PACKAGE Includes power-adjustable pedals, Rear Park Assist and power-sliding rear window with rear defogger. Not available on Regular Cab models. Requires SLE Value Package.

SLE PREFERRED PACKAGE Requires Regular Cab model. Includes driver 10-way power seat adjuster with front 40/20/40 split bench seats only, remote vehicle starter system, LED front fog lamps, rear defogger, manual tilt-telescopic steering column on V-8 models and 110-volt power outlet.

SLT PREFERRED PACKAGE Includes Front and Rear Park Assist, heated steering wheel and sliding rear window. On All Terrain, available only with All Terrain X Package.

SLE VALUE PACKAGE Includes driver 10-way power seat adjuster with front 40/20/40 split bench only, remote vehicle starter system, front LED fog lamps, Universal Home Remote, rear-window defroster, manual tilt-telescopic steering column (V-8 models), 110-volt power outlet, dual-zone climate control, Trailing Package and automatic locking rear differential on 2WD models. Not available on Regular Cab models.

SLT PREMIUM PACKAGE Includes 6" chrome tubular assist steps, Bose® premium audio system and RD5 20" polished aluminum wheels. When 6.2L V-8 is ordered, front bucket seats are required.

SLT CREW CAB PREMIUM "PLUS" PACKAGE Requires Crew Cab model. Includes NZP 20" chrome-clad wheels, Front and Rear Park Assist, heated steering wheel, power-sliding rear window, 6" rectangular chrome tubular assist steps, Bose premium audio system, 8" diagonal color touch-screen audio system with Navigation,² integrated trailer brake controller, Enhanced Driver Alert Package, heated and ventilated front bucket seats, spray-on bedliner and high-performance LED headlamps. Not available with SLT Preferred Package, SLT Premium Package or NHT Max Trailing Package.

ENTERTAINMENT/COMMUNICATION/NAVIGATION

7" DIAGONAL COLOR TOUCH-SCREEN WITH GMC INFOTAINMENT SYSTEM³ Includes AM/FM, USB ports,⁴ auxiliary jack, Bluetooth^{5,6} streaming audio for music and select phones, hands-free smartphone integration and voice-activated technology for radio and phone

8" DIAGONAL COLOR TOUCH-SCREEN WITH GMC INFOTAINMENT SYSTEM³ Includes AM/FM/SiriusXM⁶ (standard for 3 months)/HD, USB ports,⁴ auxiliary jack, Bluetooth⁵ streaming audio for music and select phones, hands-free smartphone integration and voice-activated technology for radio and phone

8" DIAGONAL COLOR TOUCH-SCREEN WITH NAVIGATION² AND GMC INFOTAINMENT SYSTEM³ Includes all features of 8" diagonal color touch-screen system plus Navigation feature

Single-slot CD/MP3 player

6-SPEAKER AUDIO SYSTEM

Bose premium audio system with 6 speakers (7-speaker system including subwoofer when ordered with bucket seats). Required when 6.2L V-8 engine and bucket seats are ordered and includes noise control system.

REAR-SEAT DVD ENTERTAINMENT SYSTEM Includes rear-seat Blu-ray/DVD player with 9.2" diagonal LCD display, 2 sets of digital wireless headphones, HDMI connector, Wi-Fi⁸ capability with select devices, Video Voice Over, 2 USB ports⁴ and A/V remote control. Requires front bucket seats and Bose premium audio system. Replaces single-slot CD/MP3 player. Crew Cab models only.

BLUETOOTH⁵ For phone, personal cell phone connectivity to vehicle audio system

4G⁷ WI-FI HOTSPOT CAPABILITY See your dealer for more details

SIRIUSXM⁶ SATELLITE RADIO Including 3 trial months of service. See your dealer for more details and availability.

EXTERIOR STYLING AND FUNCTIONALITY

ASSIST STEPS Chromed tubular with 6" rectangular design. Factory-installed on Crew Cab models only. Included with SLT Premium Package and SLT Crew Cab Premium "Plus" Package.

Tri-mode power steps. Power-retractable and rearward articulating for cargo box access. Included with Denali Ultimate Package.

BEDLINER Spray-on with GMC logo. Includes Denali logo on Denali models. On SLT, included with SLT Crew Premium "Plus" Package.

BUMPERS Front, chrome

Rear, chrome with corner step

Front, body-color

Rear, body-color with corner step

CARGO BOX Movable tie-downs, high-mounted (4)

Box rail caps

DOOR HANDLES Black

Body-color

Chrome

FOG LAMPS Front, thin-profile LED. On SLE, included and only available with SLE Preferred Package or SLE Value Package.

GRILLE SURROUND Chrome

Body-color

Chrome-accented center. Tinted chrome on All Terrain model.

Chrome with unique Denali accents

GLASS Solar-Ray tinted

Solar-Ray deep-tinted. Included and only available with Appearance Package on Sierra trim.

LIGHTS Headlamps, High-Intensity Discharge (HID), bifunctional with GMC LED signature lighting

High-performance LED headlamps with GMC signature lighting. On SLT, included and only available with SLT Crew Cab Premium "Plus" Package. On All Terrain, included and only available with All Terrain Premium Package or All Terrain X Package.

IntelliBeam, automatic high-beam on/off. Included and only available with Enhanced Driver Alert Package. On SLE, requires Regular Cab model.

Taillamps, LED with signature lighting

Under-rail LED lighting, cargo box. Included and only available with Convenience Package on Sierra trim.

MOLDINGS Body-color

Bodyside, chrome

RECOVERY HOOKS Front frame-mounted (Black). Standard on Denali, Elevation Edition models, All Terrain and all 4WD models.

TAILGATE, LOCKABLE

EZ-Lift and Lower feature

Remote locking. On Sierra trim, included and only available with Convenience Package.

WHEELHOUSE LINERS Rear. Double Cab and Crew Cab models only.

EXTERIOR MIRRORS

MIRRORS Black, manual

Power-adjustable with heated glass and driver-side spotter mirror. Included and only available with Convenience Package on Sierra trim. Mirror caps are black on Sierra trim, body-color on Elevation Edition models, SLE and Elevation Edition SLE.

Chrome cap, heated, power-adjustable, power-folding and driver-side auto-dimming with integrated turn-signal indicators and puddle lamps (includes driver-side spotter mirror). Mirror cap is black on All Terrain model.

Black, vertical trailing mirrors with manual folding and extension and lower convex spotter glass. Requires Trailing Package. Not available on Regular Cab model with Convenience Package.

Black, heated, power-adjustable vertical trailing mirrors with manual folding and extension, lower convex spotter glass, integrated turn-signal indicators, rear guidance lamps and amber auxiliary clearance lamps. Includes auto-dimming Interior rearview mirror. On Sierra trim, requires Convenience Package, Regular Cab model and Trailing Package. On SLE Double and Crew Cab models, required and only available with Max Trailing Package. On SLE Regular Cab models, requires Trailing Package.

Chrome cap, heated, power-adjustable, vertical trailing mirrors with power folding, manual extension, driver memory, lower convex spotter glass, integrated turn-signal indicators, rear guidance lamps and amber auxiliary clearance lamps. Required and only available with Max Trailing Package.

SAFETY AND SECURITY

AIR BAGS⁸ Dual-stage frontal for driver and front passenger with Passenger Sensing System

Front-seat-mounted side-impact driver and right front-passenger air bags for thorax and pelvis protection

Front and rear head-curtain air bags for all outboard seating positions

LED DAYTIME RUNNING LAMPS

LANE KEEP ASSIST WITH LANE DEPARTURE WARNING AND FORWARD COLLISION ALERT Included and only available with Enhanced Driver Alert Package. On SLE, requires Regular Cab model.

LOW SPEED FORWARD AUTOMATIC BRAKING Included and only available with Enhanced Driver Alert Package. On SLE, requires Regular Cab model.

REAR VISION CAMERA SYSTEM With dynamic grid lines

SAFETY ALERT SEAT Included and only available with Enhanced Driver Alert Package. On SLE, requires Regular Cab model.

THEFT-DETERRENT SYSTEM Unauthorized entry. Included and only available with remote vehicle starter system on SLE.

TIRE PRESSURE MONITORING SYSTEM Includes Tire Fill Alert. Does not monitor spare tire. Tire Fill Alert not available with ZW9 Box Delete.

¹The system wirelessly charges one PMA- or Qi-compatible mobile device. Some devices require an adapter or back cover. To check for phone or other device compatibility, visit mygmc.com/learn for details. ²Map coverage available in the United States, Puerto Rico and Canada. ³Full functionality requires compatible Bluetooth and smartphone. Some devices require USB connectivity. Data plan rates apply. ⁴Not compatible with all devices. ⁵Go to mygmc.com/learn to find out which phones are compatible with the vehicle. ⁶If you decide to continue service after your trial, the subscription plan you choose will automatically renew thereafter and you will be charged according to your chosen payment method at then-current rates. Fees and taxes apply. To cancel, you must call SiriusXM at 1-866-635-2349. See SiriusXM Customer Agreement for complete terms at siriusxm.com. All fees and programming subject to change. For more information about NavTraffic, visit siriusxm.com/navtraffic. For more information about Travel Link, visit siriusxm.com/travelink. Sirius, XM, SiriusXM and all related marks and logos are trademarks of SiriusXM Radio, Inc. ⁷Requires a compatible mobile device, active OnStar service and data plan. 4G service available in select markets. Visit onstar.com for coverage map, details and system limitations. Data plan provided by AT&T. ⁸A NOTE ON CHILD SAFETY: Always use safety belts and the correct child restraint for your child's age and size, even with air bags. Even in vehicles equipped with the Passenger Sensing System, children are safer when properly secured in a rear seat in the appropriate infant, child or booster seat. Never place a rear-facing infant restraint in the front seat of any vehicle equipped with an active frontal air bag. See your vehicle Owner's Manual and child safety seat instructions for more safety information.

PEACE OF MIND

Pro Grade Protection is standard on every 2018 Sierra. From maintenance to protecting your entire vehicle, you can drive with confidence.

INCLUDES 2 MAINTENANCE VISITS DURING THE FIRST 2 YEARS/24,000 MILES¹

3-YEAR/36,000-MILE BUMPER-TO-BUMPER LIMITED WARRANTY²

5-YEAR/60,000-MILE POWERTRAIN LIMITED WARRANTY²

5-YEAR/60,000-MILE ROADSIDE ASSISTANCE/COURTESY TRANSPORTATION²

¹Maintenance visits must occur within 2 years or 24,000 miles of vehicle delivery, whichever comes first. Does not include air filters. See participating dealer for other restrictions and complete details. ²Whichever comes first. See dealer for limited-warranty details.



WE'RE AS CLOSE AS THE BLUE BUTTON

Connect to a specially trained OnStar¹ Advisor just by pushing the blue OnStar button in your Sierra.

Emergency: Help When It Matters Most. OnStar protects you and your passengers in the event of an emergency with the right help, right when you need it.

Automatic Crash Response.² Using built-in sensors, Automatic Crash Response can connect you to an OnStar Advisor immediately after a crash to help get you the care you need even if you can't ask for it. Using Injury Severity Prediction technology, professionally trained Advisors can notify first responders about the likelihood of serious injury so they can provide the right help, right away. You can feel confident knowing you have a team, 24/7, to get you the assistance you need.

Roadside Assistance.³ If you've got a flat tire or are low on gas, just push the blue OnStar button, and an Advisor will get things moving with Roadside Assistance. We can use GPS technology to pinpoint where you are and send a tow truck or whatever help you need. No matter how far you are from home, you're empowered with solutions that keep you moving.

Crisis Assist. During severe weather or a crisis, OnStar can provide critical guidance during your time of need. With Crisis Assist,² our Advisors provide a fast, knowledgeable resource for emergency assistance, special routing assistance and other services. We're a 24-hour connection and central point of contact for help when you need it most.

Security: Protection You Can Count On. Breathe easy knowing a comprehensive suite of Stolen Vehicle Assistance services is available to help protect your vehicle.

Stolen Vehicle Assistance.⁴ If your vehicle is stolen, you can be assured OnStar Advisors are ready to take action. Once you report your vehicle stolen, they can pinpoint its location, work with the police to quickly recover it, slow the vehicle if the conditions are safe to do so and even prevent it from restarting. And with Theft Alarm Notification,⁵ if your vehicle alarm sounds, we'll let you know via text, email and/or a phone call. One simple call puts a team into action to help recover your vehicle quickly and safely.

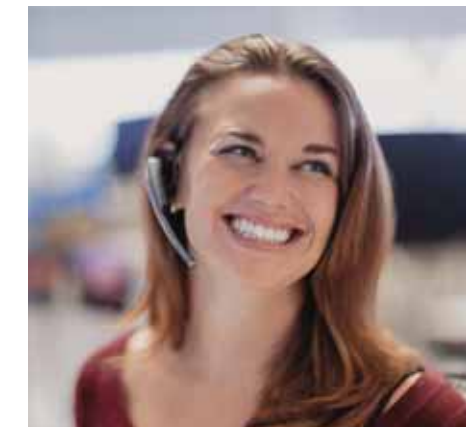

¹Visit onstar.com for coverage map, details and system limitations. Some services require paid OnStar service plan. ²Visit onstar.com for vehicle availability, details and system limitations. OnStar acts as a link to existing emergency service providers. Not all vehicles may transmit all crash data. ³Roadside service provided by Allstate Roadside Services. ⁴Services vary by model and conditions. Visit onstar.com for vehicle availability, details and system limitations. ⁵Services vary by model and conditions. Visit onstar.com for vehicle availability, details and system limitations. Theft Alarm Notification features vary by vehicle. Requires factory-installed theft-deterrent system; Security or Guidance Plan or Stolen Vehicle Assistance Plan Add-On; and selection of notification communication preference(s). Vehicles must be locked electronically to arm the factory-installed theft-deterrent system. Messaging and data rates may apply.

CONVERSATION STARTER

At GMC, we'd like to start a dialogue with you so we can learn more about each other. Join the conversation and share your passion for all things Professional Grade.



GMC.COM



IMPORTANT WORDS

PRO GRADE PROTECTION

For 2018, Sierra 1500 comes with the Pro Grade Protection Plan, which includes two maintenance visits,¹ 3-year/36,000-mile Bumper-to-Bumper Limited Warranty² and 5-year/60,000-mile Powertrain Limited Warranty,² Roadside Assistance and Courtesy Transportation.

Starting with the owner orientation—and full tank of gas—you receive when you take possession of your Sierra, to the 24-Hour Roadside Assistance, Courtesy Transportation and Travel Benefits, you receive a portfolio of owner privileges that lasts throughout your warranty. For expert product information, Roadside Assistance or other services, call 1-800-GMC-8782.

TRAVEL BENEFITS AND ROADSIDE ASSISTANCE Available around the clock: trip routing service, a program for reimbursement for trip interruption due to necessary warranty repairs, towing, flat tire change, jump-starts and more for 5 years or 60,000 miles (whichever comes first).

COURTESY TRANSPORTATION Available at participating dealers: shuttle service, reimbursement of certain public transportation or fuel expenses for overnight warranty repairs and courtesy rental for overnight work repairs. See your dealer for details.

GMC OWNER CENTER A complimentary, one-stop resource to enhance your GMC ownership experience. It's easy to sign up. Just go to gm.com/gmownercenter/gmc.

ONSTAR

 OnStar services require vehicle electrical system (including battery), wireless service and GPS satellite signals to be available and operating for features to function properly. OnStar service required. OnStar acts as a link to existing emergency service providers. Not all vehicles may transmit all crash data. Visit onstar.com for coverage map, details and system limitations. Services vary by model and conditions.

SIRIUSXM SATELLITE RADIO

 SiriusXM Satellite Radio³ is standard on select Sierra models. It includes 3 trial months of service. SiriusXM Satellite Radio makes your drive come alive with commercial-free music channels from virtually every genre, artist-dedicated channels, live performances and more. Tune in to live play-by-play from the biggest sports, exclusive entertainment from top personalities, compelling talk, hilarious comedy, world-class news, local traffic and weather and family-friendly programming. Welcome to the world of satellite radio. Visit siriusxm.com for details.

GMC CERTIFIED SERVICE

 To help your Sierra live up to its performance promise, GMC Certified Service—found exclusively at your GMC dealer—is there. With all the engineering excellence in Sierra, GM-trained technicians have the expertise to care for all of it.

ADDITIONAL NOTES

A NOTE ON CHILD SAFETY Always use safety belts and the correct child restraint for your child's age and size, even with air bags. Even in vehicles equipped with the Passenger Sensing System, children are safer when properly secured in a rear seat in the appropriate infant, child or booster seat. Never place a rear-facing infant restraint in the front seat of any vehicle equipped with an active frontal air bag. See your vehicle Owner's Manual and child safety seat instructions for more safety information.

TRAILERING AND OFF-ROAD INFORMATION Please carefully review the Owner's Manual for important safety information about trailering or off-road driving in your vehicle.

FLEET ORDERS Some standard content may be deleted with fleet orders. See dealer for details.

ENGINES GMC products are equipped with engines produced by GM Powertrain or other suppliers to GM worldwide. The engines in GMC products may also be used in other GM makes and models.

GMC.COM See more of Sierra on our website: gmc.com/sierra. More photos and information; hot links to related subjects; convenient dealer locator; pricing guide, spec out your own vehicle. Or call 1-800-GMC-8782.

BUYPOWER CARD™



Now it's even easier to get into the GMC of your dreams. Every purchase gives you Earnings redeemable toward part or even all of a new GMC, Chevrolet, Buick or Cadillac. Every year, enjoy 5 percent Earnings on your first \$5,000 in purchases and 2 percent unlimited Earnings after that. No expiration on Earnings and no limit on how much you can earn or redeem. Learn more at buypowercard.com/catalog. YOUR CARD IS THE KEY.™

IMPORTANT WORDS ABOUT THIS CATALOG We have tried to make this catalog comprehensive and factual. We reserve the right, however, to make changes at any time, without notice, in prices, colors, materials, equipment, specifications, models and availability. Specifications, dimensions, measurements, ratings and other numbers in this catalog and other printed materials provided at the dealership or affixed to vehicles are approximates based upon design and engineering drawings and prototypes and laboratory tests. Your vehicle may differ due to variations in manufacture and equipment. Since some information may have been updated since the time of printing, please check with your GMC dealer for complete details. GMC reserves the right to lengthen or shorten the model year for any product for any reason, or to start and end model years at different times. All competitive claims are based on the latest information available at the time of printing and GM Large Pickup segment.

AN IMPORTANT NOTE ABOUT ALTERATIONS AND WARRANTIES Installations or alterations to the original equipment vehicle (or chassis) as distributed by General Motors are not covered by the General Motors New-Vehicle Limited Warranty. The special body company, assembler, equipment installer or upfitter is solely responsible for warranties on the body or equipment and any alterations (or any effect of the alterations) to any of the parts, components, systems or assemblies installed by GM. General Motors is not responsible for the safety or quality of design features, materials or workmanship of any alterations by such suppliers.

NEW-VEHICLE LIMITED WARRANTY All GMC Sierra models come with a fully transferable, no-deductible 5-year/60,000-mile (whichever comes first) Powertrain Limited Warranty. GM vehicles registered in the USA are also covered for 3 years or 36,000 miles (whichever comes first). Coverage includes tires and towing to your nearest GMC dealership. Repairs will be made to correct any vehicle defect and most warranty repairs will be made at no charge. In addition, rust-through corrosion will be covered for 6 years or 100,000 miles (whichever comes first). Sierra also comes with two maintenance visits within the first 2 years/24,000 miles (whichever comes first).¹ See dealer for details.

ASSEMBLY GMC vehicles and their components are assembled or produced by different operating units of General Motors, its subsidiaries or suppliers to GM worldwide. We sometimes find it necessary to produce GMC vehicles with different or differently sourced components than originally scheduled. Since some options may be unavailable when your vehicle is assembled, we suggest that you verify that your vehicle includes the equipment you ordered or, if there are changes, that they are acceptable to you.

GMMOBILITY.COM (1-800-323-9935) GM Mobility offers financial assistance for eligible adaptive equipment to make automotive travel easier for persons with disabilities or special transportation needs. To learn more about special GM Mobility offers, visit gmmobility.com.

¹Maintenance visits must occur within 2 years or 24,000 miles of vehicle delivery, whichever comes first. Does not include air filters. See participating dealer for other restrictions and complete details. ²Whichever comes first. See dealer for limited-warranty details. ³If you decide to continue service after your trial, the subscription plan you choose will automatically renew thereafter and you will be charged according to your chosen payment method at then-current rates. Fees and taxes apply. To cancel, you must call SiriusXM at 1-866-635-2349. See SiriusXM Customer Agreement for complete terms at siriusxm.com. All fees and programming subject to change. For more information about NavTraffic, visit siriusxm.com/navtraffic. For more information about Travel Link, visit siriusxm.com/travellink. Sirius, XM, SiriusXM and all related marks and logos are trademarks of SiriusXM Radio, Inc.

©2017 General Motors. All rights reserved. GM, the GM logo, GMC, the slogans, emblems, vehicle model names, vehicle body designs and other marks appearing in this catalog are the trademarks and/or service marks of General Motors, its subsidiaries, affiliates or licensors. Facebook is a registered trademark of Facebook, Inc. Twitter is a registered trademark of Twitter, Inc. YouTube is a registered trademark of Google Inc. Instagram is a registered trademark of Instagram, LLC. Android Auto is a trademark of Google Inc. Sirius, XM and all related marks and logos are trademarks of SiriusXM Radio, Inc. Apple and CarPlay are registered trademarks of Apple, Inc.

VISIT US AT GMC.COM