

HOW WHAT WHY

THE COMPLETELY NEW
HUDSONS AND
TERRAPLANES

for **1937** are

**THREE
BIG STEPS
AHEAD**

- ☐ PERFORMANCE
- ☐ DRIVING and RIDING
- ☐ STYLE and COMFORT

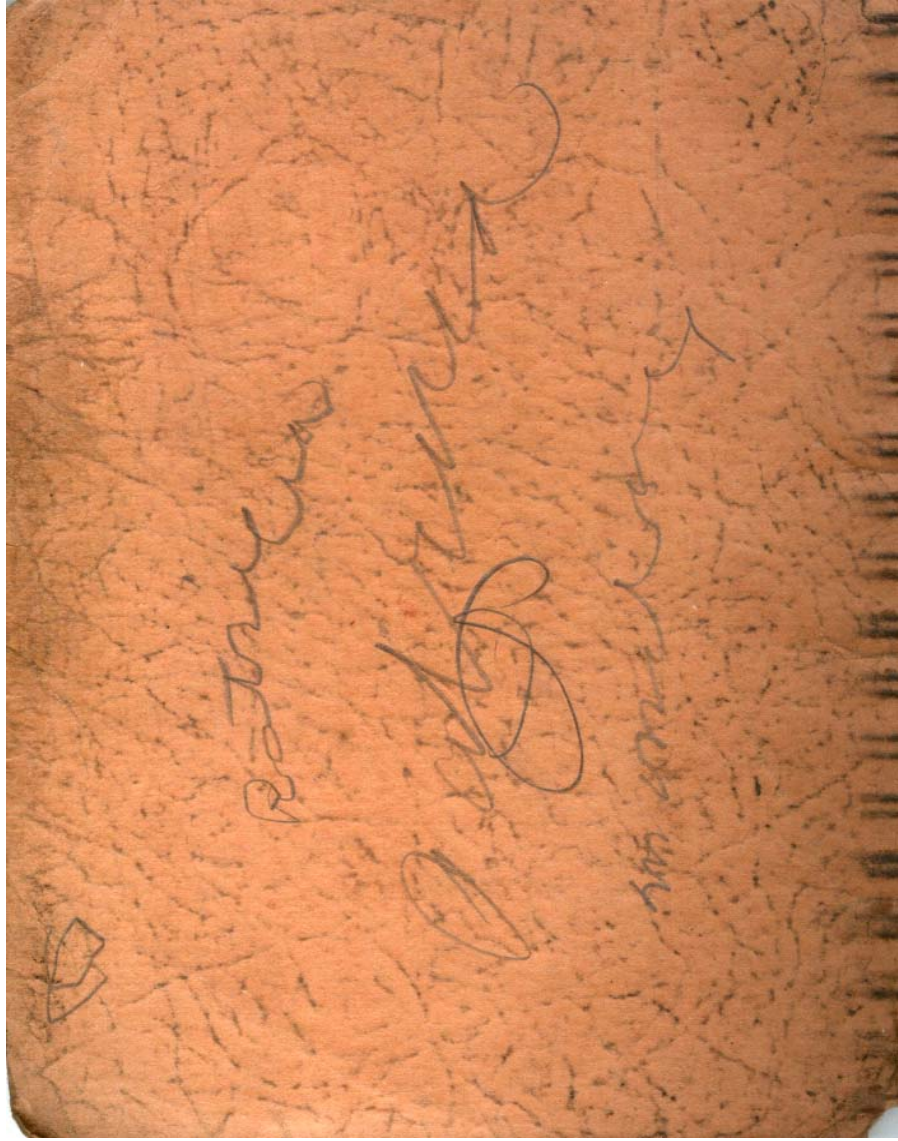

THREE BIG STEPS AHEAD	1
Pages 1 to 12	See Section
TERRAPLANE MODELS	2
Pages 13 to 21	See Section
HUDSON SIX MODELS	3
Pages 23 to 29	See Section
HUDSON EIGHT MODELS	4
Pages 31 to 38	See Section
PERFORMANCE . . . THE POWER PLANT	5
Pages 39 to 90	See Section
DRIVING AND RIDING . . . THE CHASSIS	6
Pages 91 to 120	See Section
STYLE AND COMFORT . . . THE BODY	7
Pages 121 to 148	See Section
OPTIONAL EQUIPMENT & ACCESSORIES	8
Pages 148 to 153	See Section
COMMERCIAL CAR MODELS	9
Pages 155 to 182	See Section
THE COMPANY BEHIND THE PRODUCT	10
Pages 183 to 193	See Section
PROOF THAT THEY EXCEL	11
Pages 194 to 200	See Section
DETAILED SPECIFICATIONS	12
Pages 201 to 207	See Section
INDEX TO QUESTIONS AND ANSWERS	13
Pages 208 to 212	See Section



**THREE
BIG
STEPS
AHEAD**

HUDSON-BUILT motor cars, since 1909, have been leaders in style and performance. This leadership is many more steps ahead in 1937.

1

Hudson has pioneered eighty or more "firsts" in automobile progress, many of which have become standard in the industry. It is looked upon by the public as the pace-maker for other manufacturers. This reputation is well earned. Never in its history has the Hudson Motor Car Company permitted expense to stand in the way of fine car production. Examples of this are found in the costly materials which go into Hudson-built cars and in the careful, precise, more costly manufacturing.

There is no stopping today's trend to longer, lower, wider cars, with easier control and more power. And again in 1937, Hudson has chosen to lead this trend.

This has meant the complete redesigning of cars that were completely new for 1936. It has called for completely new body dies, fender dies, hood dies and for important changes throughout the chassis. But Hudson has been glad to make this heavy investment because it insures that the progress in public acceptance, which has attracted such widespread attention to Hudson and Terraplane in 1936, will continue at a still more rapid rate in 1937.

***A BIG STEP AHEAD IN
PERFORMANCE***



Up goes Hudson and Terraplane performance for 1937 and ... down goes gasoline expense. Terraplane has stepped ahead to 96 or 101 horsepower; Hudson

to 101 or 122 horsepower. More important is the fact that with this industry-pacing stride ahead has come a 10 % saving of gasoline over 1936 Hudson-built cars which were recognized economy champions. This performance, unmatched by any cars in the price field, is obtained from standard motors using non-premium fuels.

This means even greater performance from the cars which already hold nearly four-score officially certified American Automobile Association performance records. Records for acceleration, hill climbing and high speed endurance runs have been established and held.

One important contributor to 1937 performance is double carburetion, standard on Super Terraplanes and Hudsons. Double carburetion has not been available on six-cylinder cars until Hudson progressiveness included it on 1937 models.

Backing this performance is Hudson and Terraplane ruggedness that means cars that will last, including a balanced motor made of finest material and built to closest tolerances.

In Hudson-built cars you have the pace-makers in the class-lower, longer, wider, more sweeping lines ... more style and room ... greater driving ease ... more luxury of riding ... performance that defies comparison.

(Note: Superpower domes step up power of various motors as follows: De Luxe Terraplane to 102 horsepower. Super Terraplane and Hudson Six to 107 horsepower.)

*A BIG STEP AHEAD IN
DRIVING and RIDING*

1

•

Here are cars that almost drive themselves! No need for a hand gear lever. No need to push a clutch pedal Selective Automatic Shift - available only in Hudsons and Terraplanes - takes care of all that automatically.

The driver decides when and where to shift. A flick of a finger at the improved Electric Hand and he has selected the gear he wants. He lifts his toe from the accelerator for a fraction of a second, then presses it again and gears shift smoothly and silently-at any car or engine speed.

With the new Selective Automatic Shift, there is no need for a gear shift lever obstructing the floor, for all gear selecting is done at the Electric Hand within finger length of the steering wheel.

Selective Automatic Shift in itself is a big step ahead-a step available in no competitive car. Yet, there are other exclusive features which aid in making Hudson-built cars the easiest to drive and most comfortable to ride. Among these are the new deeper, wider, stronger Double Drop "2-X" frame, the body all of steel, Duo-Automatic Hydraulic Brakes, Radial Safety Control, Rhythmic Ride and Tru-Line Steering.

*A BIG STEP AHEAD IN
STYLE and COMFORT*

•

The useful style of Hudsons and Terraplanes has gained wide admiration of motorists. It is pace-setting

style without the usual compromises in room, comfort or usefulness inside. Here again Hudson engineers have foreseen a trend and, as usual, they have elected to lead rather than follow. Here indeed is advanced style that will stay good for a long, long time.

The line of the hood, the unbroken contour of the solid steel top, joining harmonious lines of fenders sweeping to a full crown front and rear, give the low, longer lines of these larger cars unmatched graceful beauty. The large chromium hub-caps, the artistic chromium-trimmed louvres and the wide doors with their gracefully curved safety handles typify Hudson and Terraplane quality ... quality rarely found in cars priced so low.

Inside, these fine cars offer more in style and room than you ever dreamed possible. Here, for the first time, designers found ample room for expression in an automobile interior.

The brown walnut finish instrument panel shows the quality of fine furniture. The instruments are tastefully grouped and finished in harmony with the luxurious interior of the car, and at the same time can be read at a glance.

Upholstery is selected from the looms of the finest textile mills. It is carefully tailored to carry out the three-step design of interior hardware. In Hudsons and Terraplanes you have interiors as carefully created as the living room of a mansion.

HOW MUCH SHOULD A

1

By H. M. NORTHRUP, Chief Engineer,
Hudson Motor Car Co.

Every ounce of weight in an automobile should contribute to its strength and durability. When weight exceeds the point where it is useless in attaining these ends, it becomes excess baggage that costs the owner money every mile he hauls it.

No question in the industry has received more attention in recent years than the question of weight. When automobile engineers plan new models, one of their major problems is that of doing away with unnecessary tonnage and, at the same time, improving performance, comfort, economy and ruggedness.



H.M.NORTHRUP

There are four points, concerning the automobile of the future, upon which engineers already agree. Future cars will be stronger but weigh less. They will have a higher power-to-weight ratio. They will be more economical to operate. All will have bodies all of steel, because steel can be fabricated without excess weight. Steel bodies have ruggedness without sacrifice of beauty.

Excess weight in an automobile reduces its perform-

ance, increases the cost of operation and results in greater wear on operating parts. These penalties of excess weight are only one side of the question. The other is the cost of taking weight out of an automobile. It is no over-statement to say that most automobiles on the market today would have to be completely redesigned to attain the balance between power and weight that Hudson-built cars have attained. Even though engineers agree that this should be done, it is no light undertaking.

It is more than a matter of simply taking out weight. The problem is to increase the strength of each part at the same time needless weight is being eliminated. This calls for redesigning many parts and redesigning the machinery that makes them.

Harder, stronger material must be used. This often calls for the use of different cutting and finishing tools -and the scrapping of those previously used. Hudson, for example, builds cylinder blocks of a chrome-iron alloy, instead of the plain cast iron commonly used. This material is so hard and tough that it takes twice as much time for machining and requires special cutting tools.

It is by changes like these in design and manufacture that Hudson has succeeded in making Hudson-built cars stronger throughout and, at the same time, ridding them of needless weight. Such changes require a great deal of time. They involve many decisions by many people. They call for sweeping changes in production methods. They demand huge investments in machinery, equipment, tools, dies and materials.

This is a particularly slow job for companies which do not have unified engineering and production as in the Hudson organization. It is practically impossible when

one group of engineers designs the body and another the chassis ... when one concern builds the body and another completes the automobile. These are the basic reasons why other cars have not yet been able to match the Hudson and Terraplane type of construction.

There is plenty of evidence that other engineers appreciate the advantages of Hudson design and methods of manufacture. You find many cars following Hudson's lead in this direction for 1937 and will find still others following in subsequent years.

Hudson was the pioneer. Hudson already has made the required investment in time, effort and equipment. Hudson has shown the way to a new principle of motor car design and has kept its leadership through constant refinement of that principle.

Competitive salesmen, having principally tonnage to sell, have fabricated many "reasons" why it is advisable to have heavy cars. Hudson engineers, looking at these reasons promptly branded them fallacies and gave the reasons for their decisions. You most certainly will be confronted with the "weight story" in your selling, hence we are listing some of the more common fallacies and giving you the facts that answer them.

Fallacy - A heavy car will hold the road better than a lighter one, especially on curves and at high speeds.

FACT - Weight is not the governing factor in roadability. If it were, you would not see such marvelous performance, both on straightaways and on curves, by light racing cars. The center of gravity is a much more important factor. Hudsons and Terraplanes for 1937 have centers of gravity that are 1-1/2 inches lower although they retain the same road clearance.

On a curve a light car has the advantage over a heavy one, all other factors being equal. Centrifugal force on the lighter car is less ... there is less force to be corrected by the driver through his steering mechanism.

Fallacy - Extra weight makes a car ride easier.

FACT - It is not weight, but springs and shock absorbers that smooth out the bumps in a road. If weight had anything to do with comfortable riding, a truck would give a much easier ride than a passenger car.

Fallacy - Extra weight prevents "bobble" on a rough road.

FACT - Here again springs and shock absorbers solve the problem. A heavy farm wagon, hauled at high speeds over a rough road would leap in the air at every bump.

Fallacy - Heavier cars are easier to steer.

FACT - Weight has no effect on the stability of the front end. Steering is a matter of steering geometry and the correct design of mechanism.

Fallacy - Heavy cars last longer.

FACT - Every excess pound of weight means an excess pound of stress and strain. It starts a vicious circle of more power being required to haul more weight, then more weight added to withstand the strain of more power. A lighter, stronger car with Scientific Weight Design will outlast its heavier competitor. Hudsons and Terraplanes are more rugged because stronger and more expensive materials are used.



2

De Luxe Terraplanes

117-Inch Wheelbase 96 and 102 Horsepower

Sedan	Brougham	Touring Sedan
Touring Brougham		3-passenger Coupe
Victoria Coupe		Convertible Coupe
	Convertible Brougham	

•

Super Terraplanes

117-Inch Wheelbase 101 and 107 Horsepower

Sedan	Brougham	Touring Sedan
Touring Brougham		3-passenger Coupe
Victoria Coupe		Convertible Coupe
	Convertible Brougham	

HUDSON'S completely new 1937 Terraplane, in De Luxe and Super Terraplane series, with Selective Automatic Shift, is the No. 1 car of the low price field.

No. 1 in size, with 117-inch wheelbase . . . longer than any of the other three leading low priced cars.

No. 1 in power, with 96 and 101 horsepower . . . more power, and smoother power, than any of the other three. And 10% better gasoline economy.

No. 1 in performance . . . with even greater performance from the car that holds most official records in the low price field.

No. 1 in roominess . . . with wider seats, both front and back, than any of the other three leading low priced cars. More space for passengers and baggage. Level floors.

No. 1 in driving ease, with new Selective Automatic Shift . . . not available in any other low priced car.

No. 1 in interior luxury. Richness in upholstery and fittings you have always thought "too fine" for a low priced car.

No. 1 in driving vision . . . wider vision, by far, than in any of the other three leading low priced cars.

No. 1 in safety, with a body all of steel, with seamless roof of solid steel . . . pioneered by Terraplane in the low price field.

No. 1 in safe stopping, with exclusive Duo-Automatic Hydraulic Brakes . . . the only hydraulics to safeguard you with a separate safety system operating automatically from the same foot pedal.

No. 1 with improved Radial Safety Control . . . Hudson's exclusive advancement that makes riding even easier, steering still surer and stopping safer than ever.

With 16 models, eight each in De Luxe and Super Terraplane series, you now can offer a wider range of selection than ever before. There are seven standard and five optional colors.

PRINCIPAL SPECIFICATIONS

*Developed Horse-		A. M. A. Horsepower	21.6
power	96 and 101	Wheelbase	117 inches
Bore and Stroke	3 x 5 inches	Over-all lengths	194-1/2 inches
Displacement	212 cu. in.	Tires	16 x 6.00
Compression	6.2 5 to 1		

*Available with Super Power Dome for 102 of 107 horsepower.

All Terraplane models are illustrated on the following pages except the Brougham, Coupe and Convertible Coupe in the Super Terraplane series (differences between these models and the corresponding De Luxe Terraplane models are detailed on page 125), and the Touring Broughams and Touring Sedans, which are similar to the Broughams and Sedans, except that they include trunks built as an integral part of the body.

DE LUXE TERRAPLANE SEDAN - 117-Inch Wheelbase

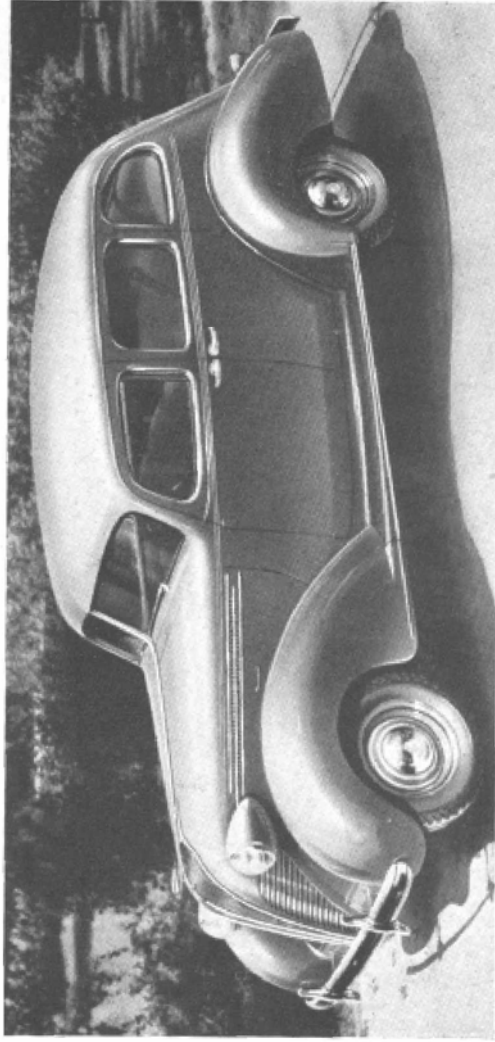

	<i>Delivered Price</i>	<i>Monthly Payments</i>
De Luxe Sedan	\$.....	\$.....
De Luxe Touring Sedan	\$.....	\$.....

2

DE LUXE TERRAPLANE BROUGHAM - 117-Inch Wheelbase



	<i>Delivered Price</i>	<i>Monthly Payments</i>		<i>Delivered Price</i>	<i>Monthly Payments</i>
De Luxe Brougham	\$	\$	Super Terraplane Brougham	\$	\$
De Luxe Touring Brougham	\$	\$	Super Terraplane Touring Brougham	\$	\$

DE LUXE TERRAPLANE COUPE - 117-Inch Wheelbase

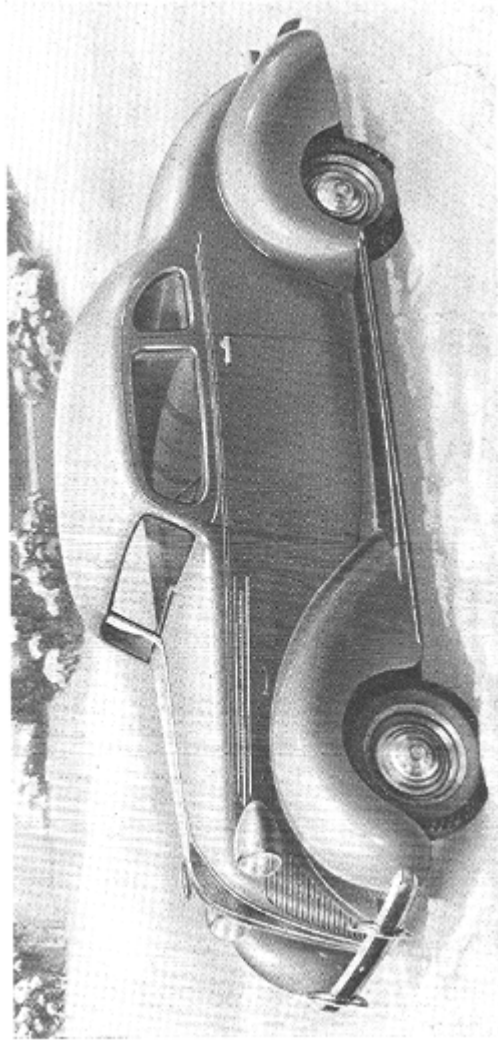

	<i>Delivered</i>	<i>Monthly</i>	<i>Delivered</i>	<i>Monthly</i>
	<i>Price</i>	<i>Payments</i>	<i>Price</i>	<i>Payments</i>
De Luxe 3-passenger Coupe	\$	\$	Super Terraplane 3-passenger Coupe	\$
De Luxe Victoria Coupe	\$	\$	Super Terraplane Victoria Coupe	\$

2

DE LUXE TERRAPLANE CONVERTIBLE BROUGHAM
117-Inch Wheelbase

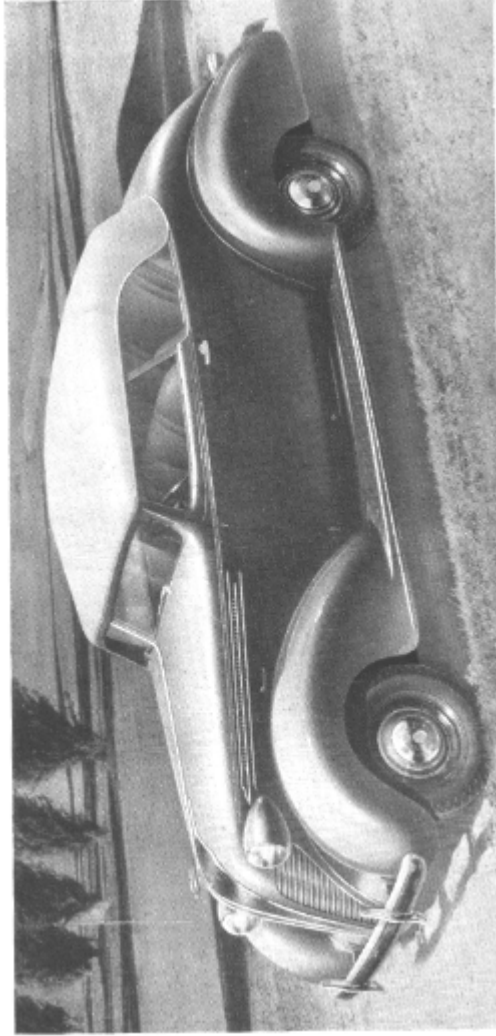

	<i>Delivered</i>	<i>Monthly</i>
	<i>Price</i>	<i>Payments</i>
De Luxe Terraplane Convertible Brougham	\$	\$

DE LUXE TERRAPLANE CONVERTIBLE COUPE
117-Inch Wheelbase

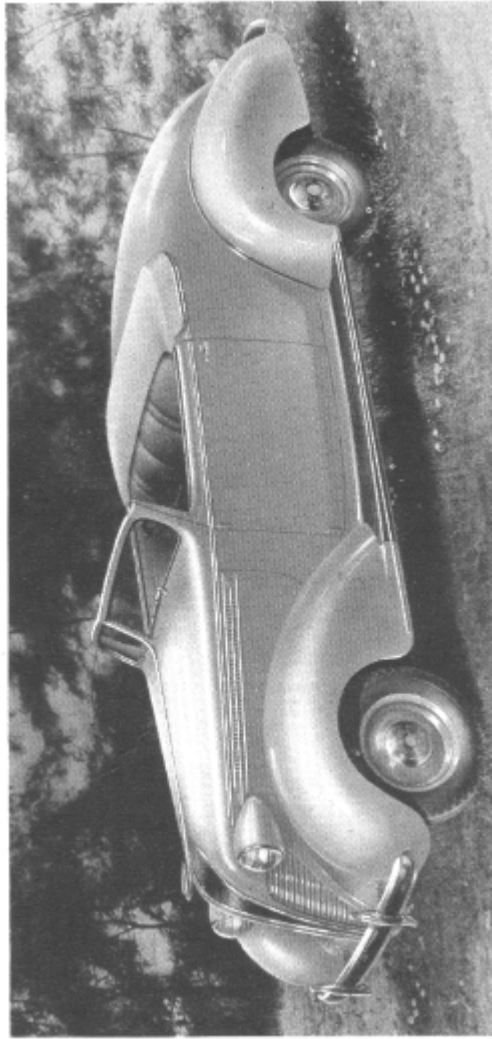

	<i>Delivered Price</i>	<i>Monthly Payments</i>
De Luxe Terraplane Convertible Coupe	\$	\$
Super Terraplane Convertible Coupe	\$	\$

2

SUPER TERRAPLANE SEDAN - 117-Inch Wheelbase

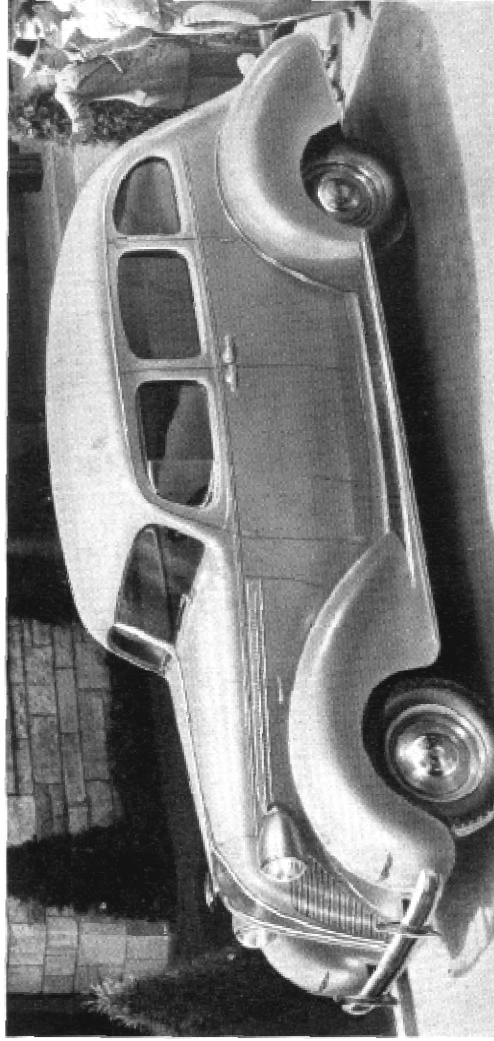

	<i>Delivered Price</i>	<i>Monthly Payments</i>
Super Terraplane Sedan	\$	\$
Super Terraplane Touring Sedan	\$	\$

SUPER TERRAPLANE CONVERTIBLE BROUGHAM
117-Inch Wheelbase

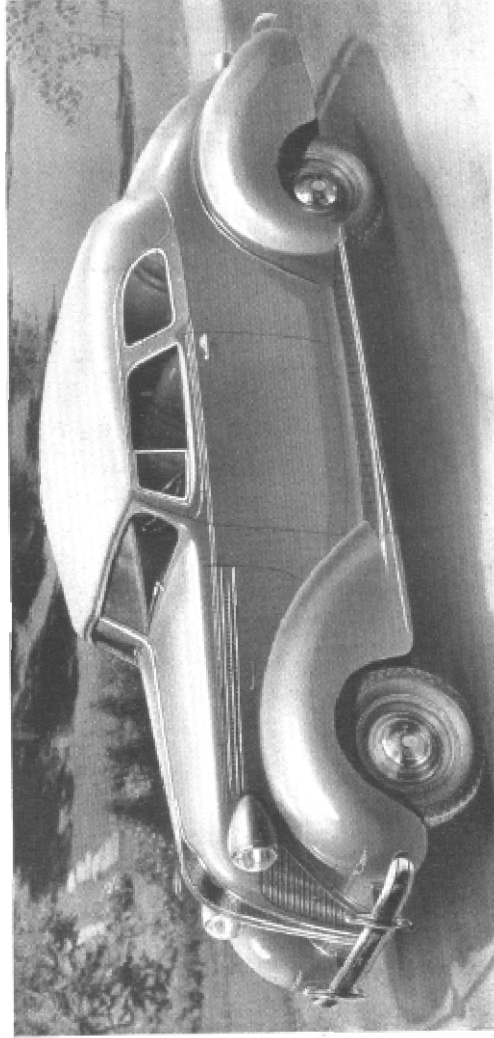

	<i>Delivered Price</i>	<i>Monthly Payments</i>
Super Terraplane Convertible Brougham	\$	\$



122-Inch Wheelbase 101 and 107 Horsepower

Custom Series

Sedan	Brougham	Touring Sedan
Touring Brougham		3-passenger Coupe
Victoria Coupe		Convertible Coupe
	Convertible Brougham	

•

THE completely new 1937 Hudson Six, with Selective Automatic Shift, is "Three Big Steps Ahead" of all the rest.

A big step ahead in driving and riding with Selective Automatic Shift . . . A flick of a finger . . . a touch of a toe . . . to shift . . . to stop . . . to go. Gears shift smoothly and surely at any engine speed or car speed.

A big step ahead in style and room - Pace-setting style outside without a single compromise in roominess, comfort or usefulness inside.

A big step ahead in performance with double carburetion, never before available in a -six-cylinder car. Power stepped ahead to 101 horsepower in a standard motor using non-premium fuel. Economy is increased 10% over the remarkably economical 1936 models.

Note these outstanding features: - Selective Automatic Shift, with improved Electric Hand . . . Double Carburetion . . . Bodies all of steel, with seamless steel roof . . . New Double Drop "2-X" Frame . . . Duo-Automatic Hydraulic Brakes . . . Hydraulic Hill-Hold . . . Radial Safety Control . . . Rhythmic Ride . . . Tru-Line Steering. Eight models, 2-way twist or mohair upholstery . . . seven new standard and five new optional colors.

The Touring Brougham and Touring Sedan, which are not illustrated on the following pages, are similar to the Brougham and Sedan, except that they include a trunk built as an integral part of the body,

PRINCIPAL SPECIFICATIONS

*Developed Horsepower	101
Bore and Stroke	3 x 5 inches
Displacement	212 cu. in.
Compression	6.2 5 to 1
A. M. A. Horsepower	21.6
Wheelbase	122 inches
Over-all length	199 inches
Tires	16 x 6.00

*Super Power Dome available, increasing horsepower to 107.

HUDSON SIX SEDAN - 122-Inch Wheelbase

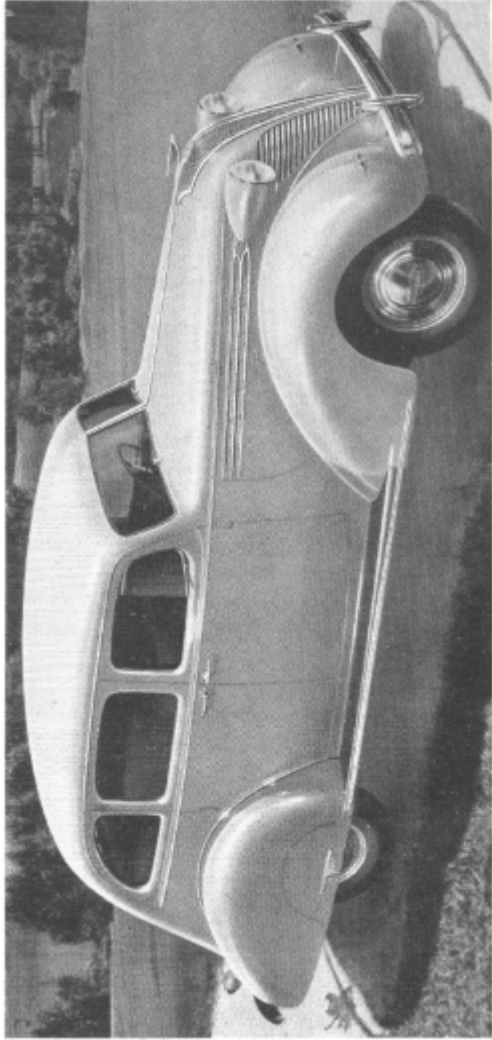

	<i>Delivered Price</i>	<i>Monthly Payments</i>
Custom Sedan	\$	\$
Custom Touring Sedan	\$	\$

3

HUDSON SIX BROUGHAM - 122-Inch Wheelbase

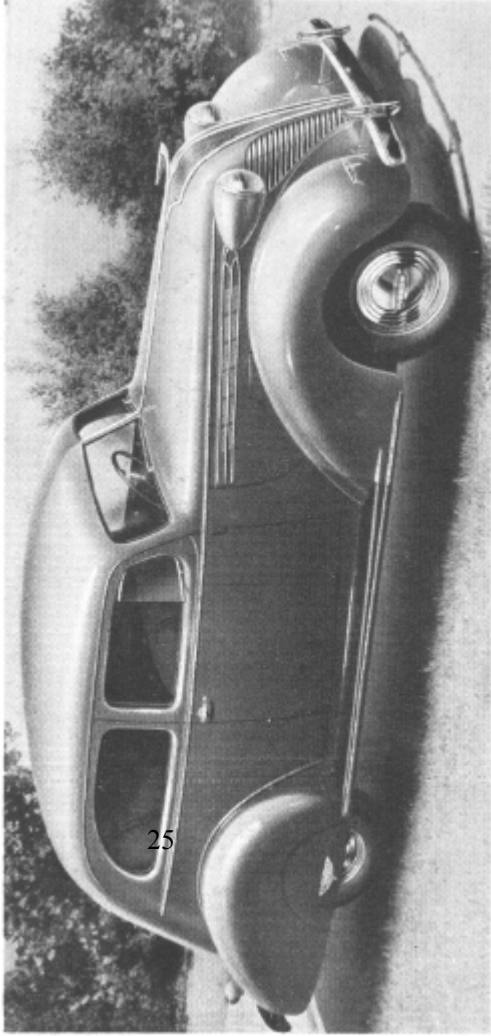

25

	<i>Delivered</i>	<i>Monthly</i>
	<i>Price</i>	<i>Payments</i>
Custom Brougham	\$.	\$.
Custom Touring Brougham	\$.	\$.

HUDSON SIX COUPE - 122-Inch Wheelbase

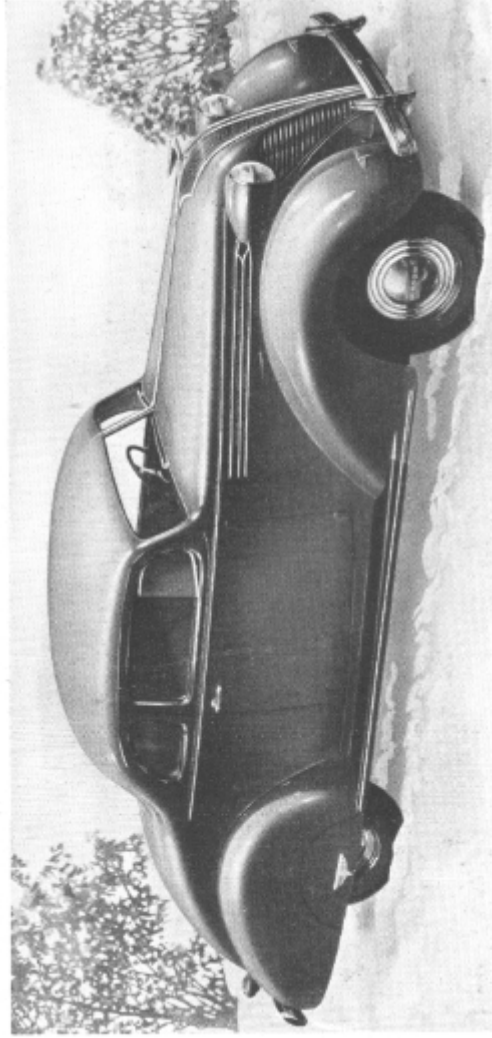

	<i>Delivered Price</i>	<i>Monthly Payments</i>
Custom Business Coupe	\$.	\$.
Custom Victoria Coupe	\$.	\$.

3

HUDSON SIX CONVERTIBLE BROUGHAM - 122-Inch Wheelbase

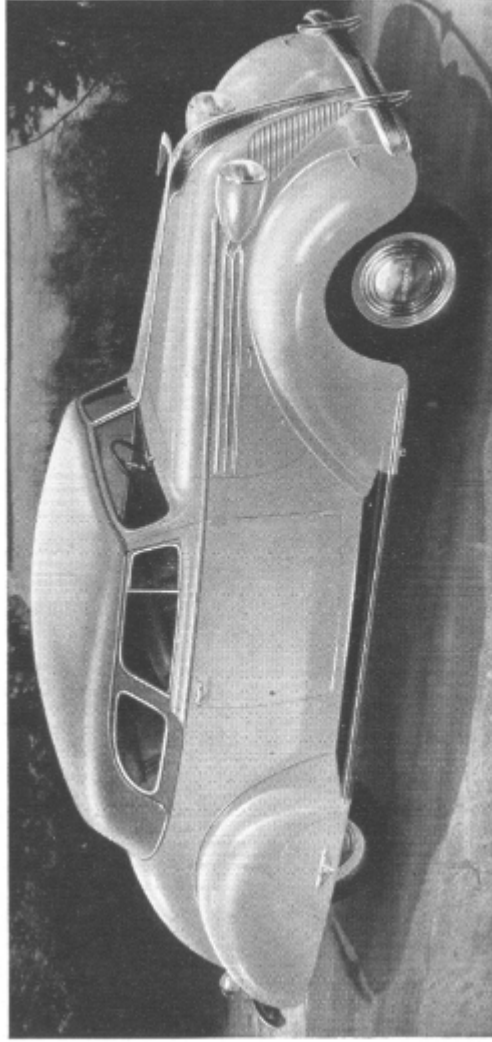

Delivered Price \$
Monthly Payments \$

Hudson Convertible Brougham

HUDSON SIX CONVERTIBLE COUPE - 122-Inch Wheelbase

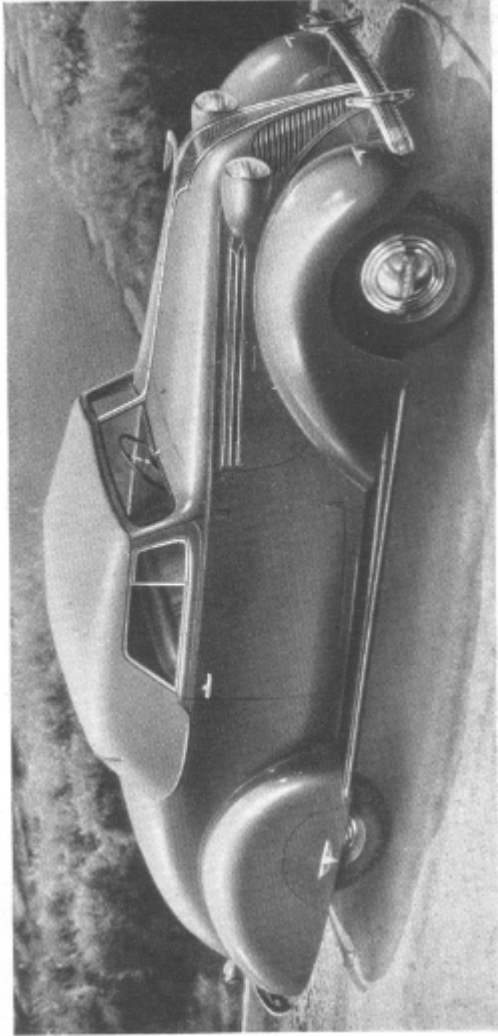

*Delivered
Price* \$
*Monthly
Payments* \$

Custom Convertible Coupe

3



4

122 and 129-Inch Wheelbase 122 Horsepower

De Luxe Series Models

Sedan*	Brougham	Touring Sedan
Touring Brougham		3-passenger Coupe
Victoria Coupe		Convertible Coupe
	Convertible Brougham	

Custom Series Models

Sedan*	Brougham	Touring Sedan
Touring Brougham		3-passenger Coupe
Victoria Coupe		Convertible Coupe
	Convertible Brougham	

*122 and 129 inch wheelbase

CARS, that step to the top in luxury yet are priced just above the lowest. The completely new 1937 Hudson Eight, with Selective Automatic Shift, in 122 and 129-inch wheelbase. This is the first time an automobile with 129-inch wheelbase ever was available at less than \$1000. The Hudson Eight is three big steps ahead of all the rest.

A big step ahead in driving and riding with Selective Automatic Shift . . . A flick of a finger . . . a touch of a toe . . . to shift . . . to stop . . . to go. Gears shift smoothly and surely at any engine speed or car speed.

A big step ahead in style and room - Pace-setting style outside without compromise in roominess, comfort or usefulness inside.

A big step ahead in performance with double carburetion. Power stepped ahead to 122 horsepower in a standard motor using non-premium fuel. Economy is increased 100/0 over the remarkably economical 1936 Hudsons.

The completely new Hudson Eights have these important sales features: Selective Automatic Shift, with improved Electric Hand . . . Double Carburetion . . . Bodies all of steel, with seamless steel roofs . . . New Double Drop "2-X" Frame . . . Duo-Automatic Hydraulic Brakes . . . Hydraulic Hill-Hold . . . Radial Safety Control . . . Rhythmic Ride. Available in 12 body models, seven new standard colors and five optional colors. Choice of 2-way twist or mohair upholstery in De Luxe models; custom loom cloth in Custom models.

All body types illustrated on the following pages are offered in both the De Luxe and the Custom series. Touring Broughams and Touring Sedans, which are not illustrated, are similar to the Sedans and Broughams, except that they include trunks built as an integral part of the body.

PRINCIPAL SPECIFICATIONS

Developed Horsepower	122
Bore and Stroke	3 x 4-1/2 in.
Displacement	254.47 cu. in.
Compression	6.25 to 1
A. M. A. Horsepower	28.8
Wheelbase	122 or 129 inches
Over-all length	199 or 203 inches
Tires	16 x 6.25

HUDSON SIX SEDAN - 129-Inch Wheelbase

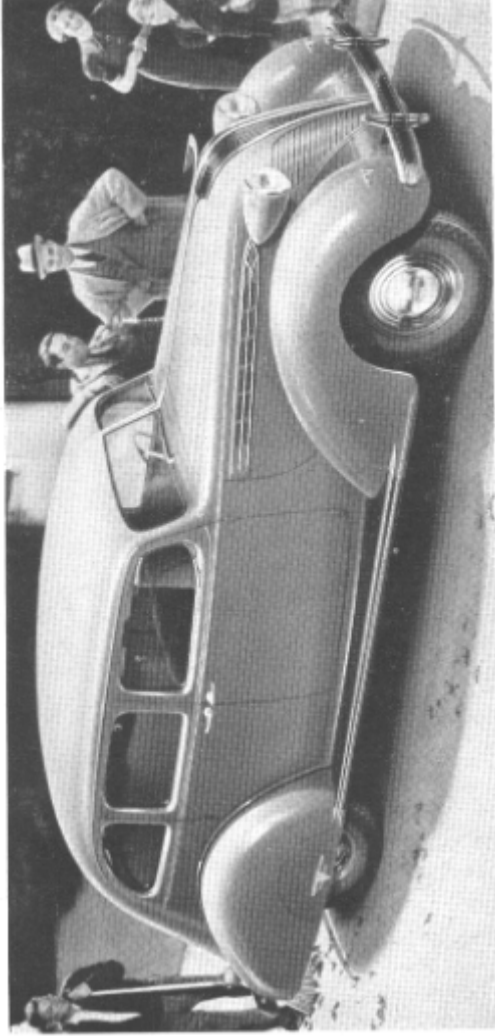

	<i>Delivered Price</i>	<i>Monthly Payments</i>		<i>Delivered Price</i>	<i>Monthly Payments</i>
De Luxe Sedan (129" w. b.)	\$	\$	Custom Sedan (129" w. b.)	\$	\$
De Luxe Touring Sedan (129" w. b.)	\$	\$	Custom Touring Sedan (129" w. b.)	\$	\$

HUDSON SIX SEDAN - 122-Inch Wheelbase

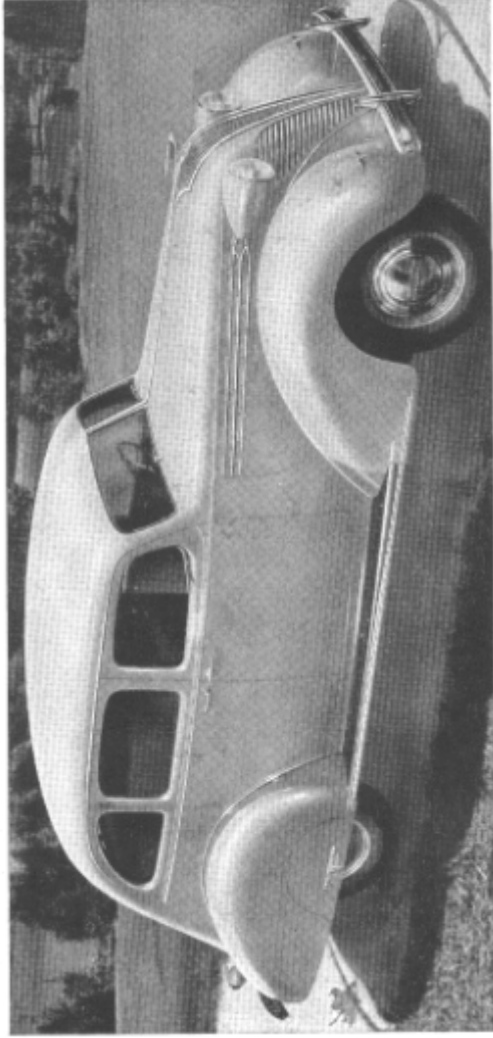

	<i>Delivered Price</i>	<i>Monthly Payments</i>	<i>Delivered Price</i>	<i>Monthly Payments</i>
De Luxe Sedan (122" w. b.)	\$	\$	Custom Sedan (122" w.b.)	\$
De Luxe Touring Sedan (122" w.b.)	\$	\$	Custom Touring Sedan (122" w.b.)	\$

HUDSON EIGHT BROUGHAM - 122-Inch Wheelbase

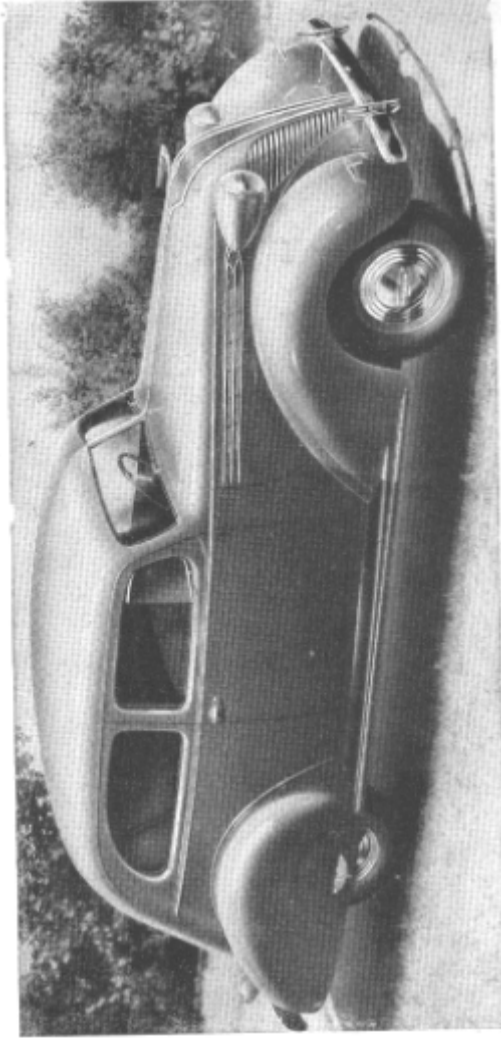

	<i>Delivered Price</i>	<i>Monthly Payments</i>		<i>Delivered Price</i>	<i>Monthly Payments</i>
De Luxe Brougham	\$	\$	Custom Brougham	\$	\$
De Luxe Touring Brougham	\$	\$	Custom Touring Brougham	\$	\$

4

HUDSON EIGHT COUPE - 122-Inch Wheelbase

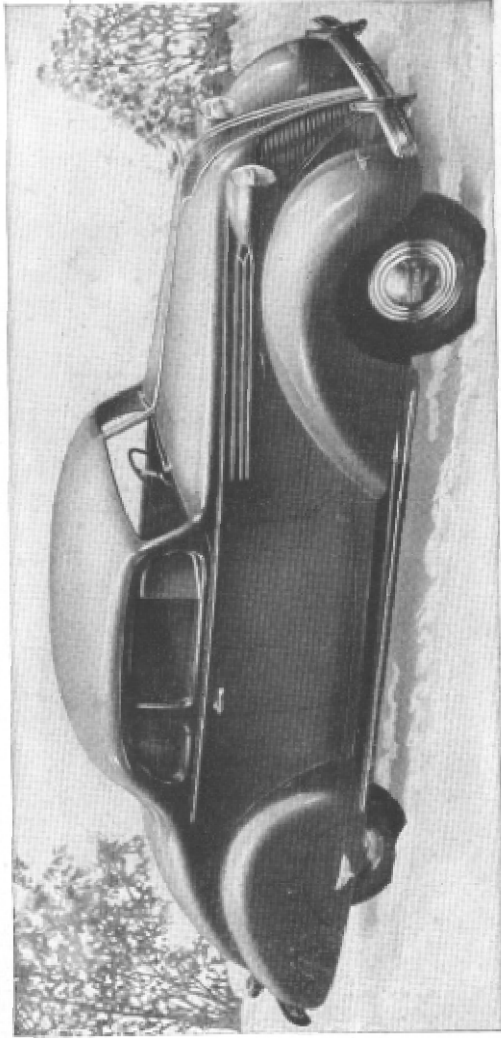

	<i>Delivered Price</i>	<i>Monthly Payments</i>	<i>Delivered Price</i>	<i>Monthly Payments</i>
De Luxe 3-passenger Coupe	\$	\$	Custom 3-passenger Coupe	\$
De Luxe Victoria Coupe	\$	\$	Custom Victoria Coupe	\$

HUDSON EIGHT CONVERTIBLE BROUGHAM
 122-Inch Wheelbase

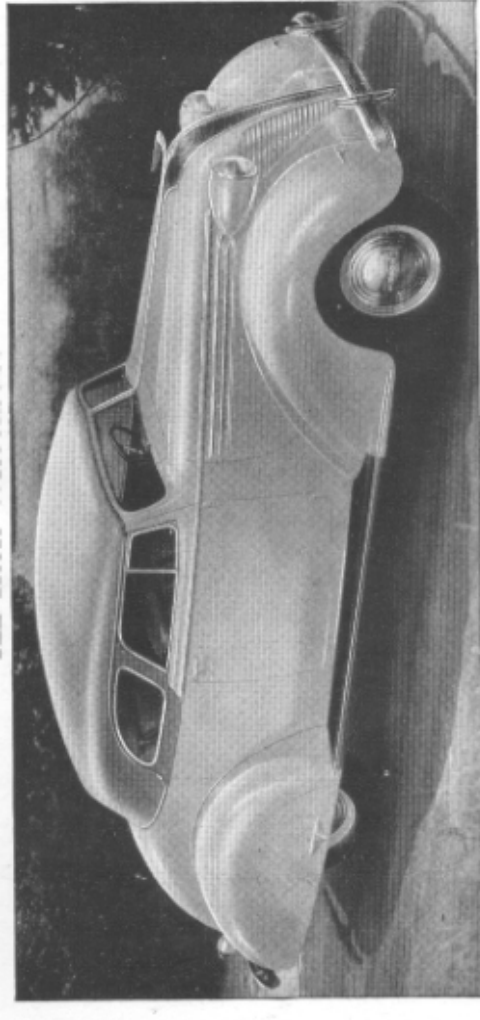

	<i>Delivered Price</i>	<i>Monthly Payments</i>
De Luxe Convertible Brougham	\$.	\$.
Custom Convertible Brougham	\$.	\$.

4

HUDSON EIGHT CONVERTIBLE COUPE - 122-Inch Wheelbase



	<i>Delivered Price</i>	<i>Monthly Payments</i>
De Luxe Convertible Coupe	\$.....	\$.....
Custom Convertible Coupe	\$.....	\$.....

STEP NUMBER ONE

**PERFORMANCE**

THE POWER PLANT

SMOOTH power, the smoothest ever built into an automobile motor, has been stepped ahead in 1937 to 96 or 101 horsepower for Terraplanes and to 101 or 122 horsepower for Hudson. Linked with this premium performance, obtained from standard motors using non-premium gasoline, is 10 per cent greater economy.

Outstanding among the developments of these completely new 1937 power plants is the double carburetion, standard on Super Terraplanes and Hudsons. Super Terraplane and Hudson Six are the first six-cylinder cars ever to offer double carburetion.

These champions of motordom have been refined and improved throughout, creating new performance standards for the motors which were conceded to outperform any stock car engine in the world . . . the

champion which holds 78 officially certified American Automobile Association stock car performance records.

In commenting upon Hudson-built cars, Reid Railton, famed English automobile engineer and designer of Sir Malcolm Campbell's "Bluebird" said:

"These cars will out-perform any car made in England and-so far as I know-in the world! They excel in power for their weight, and in their quietness and smoothness, excel any engine built by anyone."

Hudson-built motors are the smoothest on the road today. There is a sound, fundamental reason for this. Hudson originated the balanced crankshaft and has contributed more to automobile motor development than any other company.

Only in Hudson and Terraplane will you find Duo-flo oiling, the system which filters and cools the oil before recirculation. The two generous streams of oil from the over-size dual pump lubricate every part of the motor the instant it starts and the flow of lubricant increases with motor speeds.

In Hudson-built motors you find such refinements as cam ground silicon aluminum pistons, four pinned piston rings, large bearing surfaces, high chrome alloy cylinder block and numerous other qualities not found in other cars in Hudson and Terraplane price range.

With Hudson or Terraplane you can demonstrate the smoothest motor you ever saw ... a car that will flash out of tight places in traffic ... that will glide over any hill on any main highway in America in high ... a motor you will be proud to sell because you know it will have its original pep and smoothness after thousands of miles.

THE POWERFUL
HUDSON EIGHT

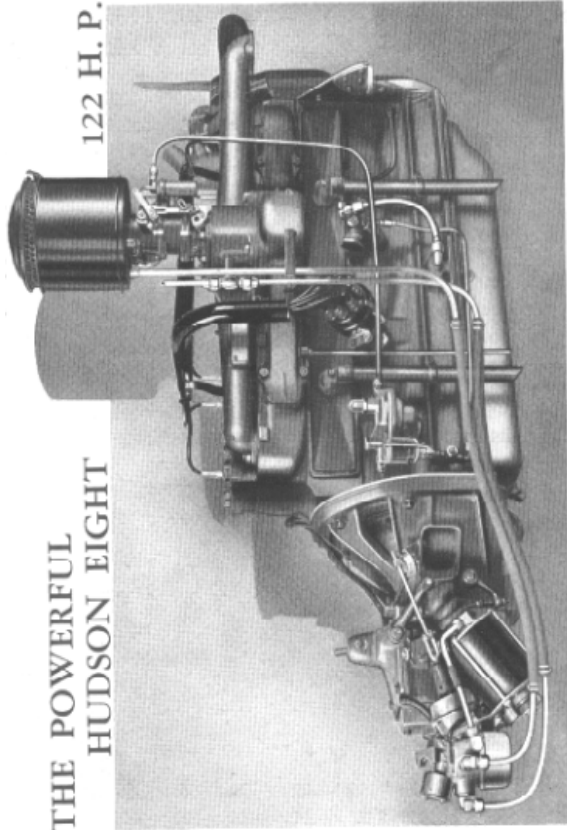

122 H. P.

**HUDSON-BUILT CARS for 1937
are THREE BIG STEPS AHEAD in**

- P** -PERFORMANCE, including Economy
- D** -DRIVING and RIDING, including Safety
- S** -STYLE and COMFORT

Every part in Hudson-built cars contributes to one or more of these superior qualities. In reading the following pages, note the symbols in the margin beside the answers.

P They point out why Hudson built cars are ahead in each of the three big

and important values.

**POWER PLANT QUESTIONS
AND ANSWERS**

1 - *Of what type are Hudson and Terraplane motors?*

P High compression, high speed L-head.

2 - *How many automobiles have L-head motors?*

In 1935, 19 out of 22 American manufacturers, building 67 per cent of all American cars, used L-head motors. 3

3 - *How many cylinders in Hudson and Terraplane motors?*

Terraplane, 6; Hudson, 6 and 8.

P **4 - *What is the bore and stroke?***

Terraplane - 3" x 5"; Hudson Six - 3"x5"; Hudson Eight

P -3"x4-1/2".

5 - *What is the displacement?*

Terraplane - 212 cu. in.; Hudson Six - 212 cu. in.; Hudson Eight - 254 cu. in.

6 - *What are the compression ratios?*

6.25 to 1 in all models.

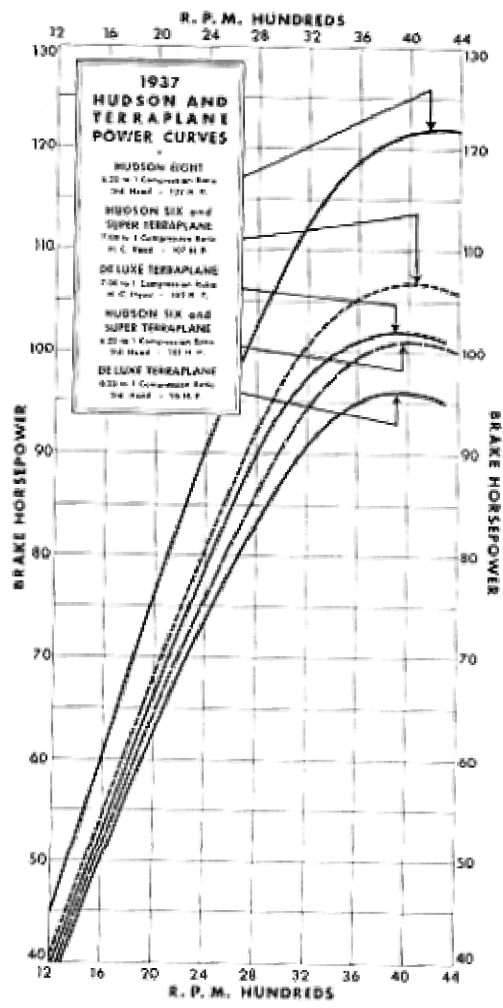

7 - What are the actual developed horsepowers?

	Terraplane De Luxe	96 at 3900 r. p. m.
P	Terraplane Custom	101 at 4000 r. p. m.
	Hudson Six	101 at 4000 r. p. m.
	Hudson Eight	122 at 4200 r. p. m.

8 - Are "power-dome" cylinder heads available?

Yes-on Terraplanes and Hudson Sixes. With the super power dome aluminum heads (7 to 1 compression ratio), the horsepowers are:

P	De Luxe Terraplane	102 at 3900 r. p. m.
	Super Terraplane	107 at 4000 r. p. m.
	Hudson Six	107 at 4000 r. p. m.

9 - What is the horsepower per cubic inch of piston displacement?

P	With standardheads: DeLuxeTerraplane - .453; Super Terraplane and Hudson Six - .476; Hudson Eight - .480. With 7-to-1 compression heads: De Luxe Terraplane - .481; Super Terraplane and Hudson Six - .505.
----------	---

10 - Is this a high power-ratio?

P	Yes. Probably the highest on any production motor in the world - exceeded only by racing and special super-charged motors.
----------	--

11 - Why do Terraplane and Hudson engines have the greatest power per cubic inch of piston displacement?

Perfectly compensated reciprocating parts; elimination of useless dead weight; high-compression heads; an exclusive valve tappet and cam design; the exclusive Hudson oiling system; and other factors co-ordinated into a balanced unit.

12 - How many engine revolutions per mile?

Terraplane and Hudson Six - 3096; Hudson Eight - 3042.

13 - What is the A. M. A. horsepower?

Terraplane-21.6

Hudson-28.8

14 - What does A. M. A. horsepower mean?

A mathematical formula used for taxation in some states and involving only the bore and number of cylinders. It ignores stroke, compression, ignition, valves, cooling or other vital factors of engine efficiency which affect actual horsepower.

It has no relation whatever to actual brake horsepower. The superior power-to-weight ratio of Hudsons and Terraplanes is figured from actual, usable horsepower.

15 - What does power-to-weight ratio mean?

The relation of a motor car's developed horsepower to its total weight, or the number of pounds of weight divided by the number of horsepower.

16 - Is this important to a car's performance?

Yes. More important than anything else. A strong man can lift a 50-pound weight easier than a weak man. The more power an engine has in proportion to its weight, the faster and longer it will run-with proportionately less wear and tear on the whole car.

17 - Do Terraplanes and Hudsons have a high power-to-weight ratio?

Yes. All Hudson-built cars have the airplane ratio-one horsepower to about 30 pounds. The ratios of other cars range as high as 1 horsepower to 48 or 50 pounds.

18 - Where is the engine number stamped?

On Terraplanes and Hudson Sixes: On the left side of the engine, on the boss at the rear of the water jacket. It is above the side water manifold and near the cylinder head.

On Hudson Eights: On the left side of the engine, on the boss at the *front* of the water manifold.

CYLINDER BLOCK, CRANKCASE AND CRANKSHAFT

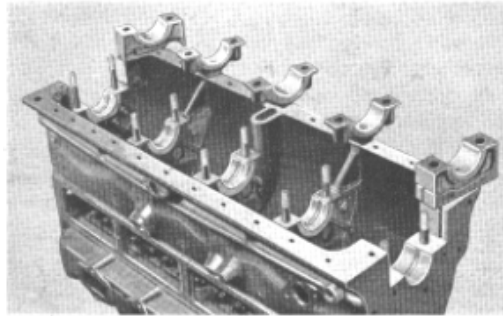

Hudson Eight Crankcase showing "Bridge-Truss" Ribbing.

19 - *What type of cylinder block and crankcase construction is used?*

They are cast integrally. The crankcase is heavily ribbed internally, the ribs supporting the massive main bearings. This "bridge-truss" construction provides an unusually rigid crankcase, which preserves perfect alignment of the heavy, inherently compensated crankshaft and the camshaft.

P **20** - *What material in the block and crankcase?*

A high chrome alloy used only in Hudson-built motors. Provides a hard wear-resisting cylinder bore and increases engine life tremendously. It is so hard that it provides a valve seat as enduring as any in the industry, without the many disadvantages of a separate insert.

21 - *Why do Hudsons and Terraplanes not have special hardened inserts for valve seats?*

Valve seat inserts are needed only when the block is made of softer metal.

22 - *Is there any advantage in the Hudson design compared with the valve seat insert?*

Yes. No matter how tightly a valve seat insert may fit in the block, heat will not dissipate through a junction as freely as through the unbroken metal of the chrome alloy block (note illustration). This junction is virtually an insulator. Thus heat is conducted more quickly in Hudsons and Terraplanes, performance is improved, and the life of the valves greatly increased.

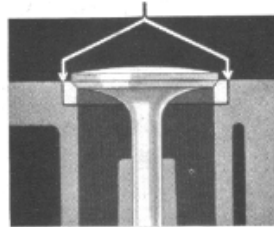

Valve seat inserts as used in engines made of softer metal. The junction (note arrows) between the insert and cylinder block metal hinders conduction and dissipation of heat. Hudson-built motors, with chrome alloy block do not require valve seat inserts.

23 - *Why don't other manufacturers use high chrome alloy blocks?*

Because the castings cost more, the factory tools for machining them cost more, the factory's machining speed is only half as fast, and thus twice as costly. But the Hudson or Terraplane owner gets a better car.

24 - *How is the unusually fine finish of the cylinder bore obtained?*

The bore is power "honed" to a limit of one thousandth of an inch. This hardens, as well as smooths the bore

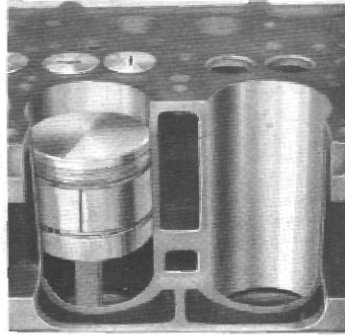

Cut-away view of Hudson cylinder block showing mirror smooth cylinder walls, water-jacketing, T-slot low-expansion piston with one of its four rings below wrist pin, and valve seating.

surface to a satin finish. It increases the engine life and aids the "breaking in" process by shortening the process while protecting cylinder surfaces.

25 - How is the crankcase ventilated?

- P** By two ventilator pipes extending from the front and rear tappet covers to a point below the motor, where the current of passing air dissipates the fumes and prevents them from getting into the passenger compartment.

26 - Does crankcase ventilation have any purpose, other than dissipation fumes?

Yes, a much more important purpose. It carries away water vapor, which is one of the major products of combustion and which would emulsify the motor oil. It also rids the crankcase of sulphurous acid fumes coming from the combustion of low-grade fuels containing sulphur. These fumes have a harmful effect on

bright steel parts. The water and acid are vaporized by the churning action of the connecting rods, thus permitting their escape through the ventilator pipes. Hudson-built motors are the only ones in which the oil is so churned.

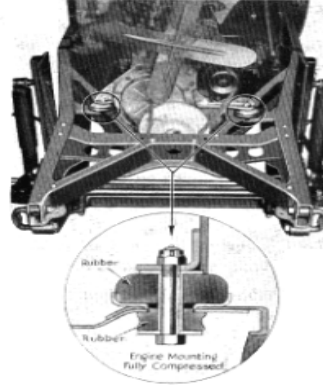

The ventilators also permit a breathing action eliminating any possibility of crankcase pressure being built up by the rapidly reciprocating connecting rods and pistons.

(Below): Cross section view of live rubber engine mounting.

(Above): Position of two front mountings. The third point of suspension is at the rear of the engine, on a sturdy frame cross

27 - How are Hudson and Terraplane motors mounted on the chassis?

On live rubber cushions at three points. These prevent vibration and sound from being transmitted from motor to chassis and body. Three-point suspension provides further insurance against transmission of vibration and sound by permitting the engine to rock slightly as if cradled.

28 - *What about the so-called "floating power" mounting?*

The inherent smoothness and minimum vibration of Hudson-built motors do not require so loose and flexible a mounting. Engines with more violent vibration periods require a more flexible mounting. On the other hand, the looser type of mounting also permits increased engine vibration. On such motors, all accessory units, such as the carburetor, distributor, etc., are subject to the same violent vibrations, which restrict their effectiveness and shorten their lives.

D 29 - *Is the motor in Hudson-built cars moved forward to balance the weight over the front and rear axles?*

No, the motor is mounted to the rear of the axle, and there is more weight on the rear axle than on the front.

30 - *Does an equal distribution of weight on the axles give smoother driving?*

While this may appear true in theory, it is untrue in practice. Certain manufacturers were compelled to move the engine forward in order to get sufficient body room. Hudsons and Terraplanes do not have to resort to this expedient. Cars with the engine moved forward are notoriously hard and uncomfortable to steer and their practical top speed is reduced several miles an hour. The principal reason is: The heavier weight on the front axle puts a greater burden on the steering mechanism and the driver has to "carry the added weight." This heavier weight also causes much greater front tire wear. As an example - shortly before the Hudson Eight set its records at Muroc Dry Lake, California, another manufacturer tested his car, which has a forward-mounted engine, at the same testing ground.

Many new tires were required on the other car during a 24-hour run, but the Hudson, running at higher speeds, went 24 hours without a single tire change

31 - *What type of crankshaft is used?*

An inherently compensated and balanced crankshaft, with compensating counter-balances forged integrally with the shaft. It is balanced both statically (at rest), and dynamically (in motion, or while revolving) so that there is no centrifugal "throw" or "whip." The inherently compensated crankshaft was originated and patented by Hudson.

P



The Hudson Eight patented crankshaft which is inherently compensated, and balanced both statically and dynamically.

32 - *What is the number of compensating weights?*

Terraplane - 8 Hudson - 8

P

33 - *What is the length and weight of the shaft?*

	Length	Weight
Terraplane and Hudson Six	27-29/32"	73.25 pounds
Hudson	36-13/32"	77.50 pounds

34 - *Do the relatively heavy weight and short length have any significance?*

P

Yes. Hudson and Terraplane crankshafts have less tendency to whip than longer and lighter shafts. The crankshafts maintain a steady alignment even at highest speeds.

35 - *What is a "compensated" crankshaft?*

Any revolving mass, such as a crankshaft, tends, through centrifugal force, to pull out of shape at high speed. Crankshafts of Hudsons and Terraplanes have the counter-balancing weights so placed that they set up compensating forces that are equal to, and opposite, the forces acting

P

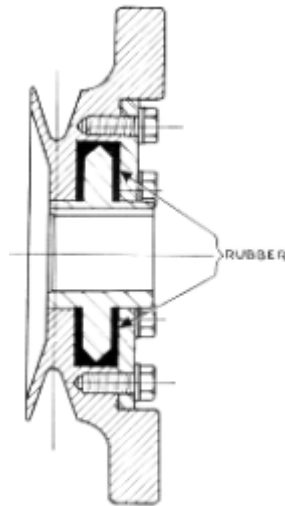

Cross section drawing of vibration damper showing live rubber

on the crankshaft proper. Thus the crankshafts are "inherently compensated." Even when running at high speed, "Hudson-built" crankshafts exert no more pressure on their bearings than when running at low speeds.

36 - *Is there a crankshaft damper?*

Yes. Although the crankshaft is inherently compensated against vibration caused by centrifugal action, the intermittent power impulses of the motors would, at higher speeds,

cause an audible vibration or sound. The Hudson damper, which completely dampens or absorbs such vibrations, is at the front end of the shaft and

P consists of two members. One is joined rigidly to the crankshaft, and the other, virtually a small flywheel, is mounted on the rigid member, but separated by live rubber surfaces. It has no wearing parts to be adjusted or replaced.

37 - *What type of main bearing is used?*

Bronze-backed bearings, lined with highest quality babbitt metal. Since the compensated crankshaft minimizes bearing friction and the Duo-flo oiling system keeps a perfect oil film between bearing surfaces, the amount of heat absorbed by crankshaft

bearings is relatively low. Bronze is an excellent heat conducting medium. The babbitt lining is comparatively thin and the heat is immediately conducted through the babbitt to the bronze and then to the crankcase structure itself, where it is dissipated. Bearings in Hudson-built engines frequently operate for the life of the car without mechanical adjustment.

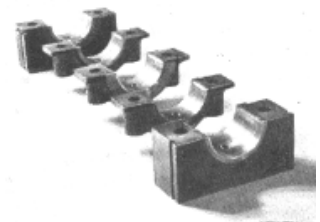

Main bearings in the Hudson Eight Engine - note size and sturdiness

38 - What is the number and size of main hearings?

TERRAPLANE AND HUDSON SIX -

	Dia. In.	Length In.	Area Sq. In.	Surface Sq. In.
No. 1	2 ¹¹ / ₃₂	1½	3.516	11.046
No. 2	2 ³ / ₈	1¾	4.156 (takes thrust)	13.056
No. 3	2 ¹³ / ₃₂	2 ³ / ₈	5.721	17.973

Total area - 13.393 sq. inches.

Total surface - 42.075 sq. inches.

HUDSON EIGHT -

	Dia. In.	Length In.	Area Sq. In.	Surface Sq. In.
No. 1	2 ⁹ / ₃₂	1 ⁵ / ₈	3.706	11.643
No. 2	2 ⁵ / ₁₆	1 ³ / ₈	3.180	9.990
No. 3	2 ¹¹ / ₃₂	1 ⁷ / ₈	4.371 (takes thrust)	13.732
No. 4	2 ³ / ₈	1 ³ / ₈	3.266	10.260
No. 5	2 ¹³ / ₃₂	2	4.812	15.117

Total area - 19.335 sq. inches.

Total surface - 60.742 sq. inches.

*(NOTE- Information given out by some automobile manufacturers confuses "bearing area" and "bearing surface," giving the impression that the bearing surface in their engines is the effective bearing area, whereas the bearing surface is always much greater than the area. This difference should be kept clearly in mind.)

In the 3-bearing engine (Terraplane and Hudson Six), each piston stroke is carried on two large bearings. In the 4-bearing engine, on two medium-size bearings. In the 7-bearing engine, on one medium-size and one small, or on two small, bearings.

39 - Do 6-cylinder engines with 4 or 7 main bearings have an advantage over the Terraplane and Hudson Six engines, which have three?

No. The Terraplanes and Hudson Six engines have the advantage. No matter how many bearings an engine may have, the load of the piston stroke is concentrated on only two of them at one time - the two bearings adjacent to that particular connecting rod pin. Obviously, the larger these two bearings are, the less strain and wear on them, and the

quieter and more trouble-free the operation of the engine.

In Terraplane and Hudson Six engines, each piston stroke is carried by a larger pair of bearings (larger bearing area) than in any other car of their price or size class (1936 specifications are the basis for this statement).

For example, compare the pairs of bearings that carry the No. 1 and the No. 6 piston strokes in the Hudson Six and Terraplane engines with the bearings doing the same work in two

3 BEARINGS

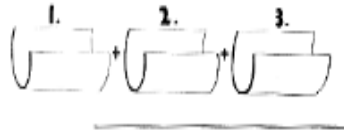

4 BEARINGS

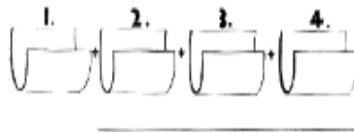

7 BEARINGS



In the 3-bearing engine (Terraplane and Hudson Six), each piston stroke is carried on two large bearings. In the 4-bearing engine, on two medium-size bearings. In the 7-bearing engine, on one medium-size and one small, or on two small, bearings.

other prominent six-cylinder cars having four and seven main bearings respectively:

	<i>Total Area of 2 Bearings Carrying Piston Stroke</i>	
Terraplane and Hudson	<i>No. 1 Piston</i>	<i>No. 6 Piston</i>
Six (3 main bearings)	7.672 sq. in.	9.677 sq. in.
Car X (4 main bearings)	5.762 sq. in.	7.264 sq. in.
Car Z (7 main bearings)	5.432 sq. in.	6.363 sq. in.
Terraplane and Hudson Six Advantage -		
Over Car X	1.91 sq. in.	2.413 sq. in.
Over Car Z	2.40 sq. in.	3.314 sq. in. (or 52%)

PISTONS AND CONNECTING RODS

40 - *Of what type and material are the pistons?*

The T-slot, low-expansion, cam-ground, "pinned" ring type, made of silicon aluminum alloy. This alloy, which is 10 per cent lighter even than aluminum, is also extremely hard and provides not only an excellent bearing surface but also freedom from scoring, assuring a longer motor life. The pistons' have a glass-smooth finish. The T-slot design prevents warping under temperature changes. "Cam-ground" means that the pistons have a slight elliptical shape, instead of being perfectly round, but when the piston expands

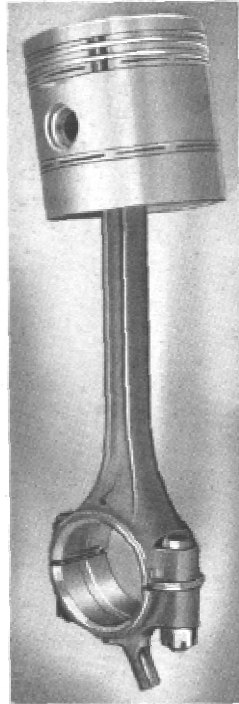

*Piston and Connecting
Rod assembly.*

as it becomes hot, it becomes perfectly round. The cam ground principle permits the piston to be fitted more closely, thus eliminating "piston slap" when the engine is cold.

41 - How many piston rings are used?

Four. Three rings (two compression and one oil) are above the wrist-pin, and one oil ring is below the pin. Having the lower oil ring below the pin greatly reduces the possibility of oil leakage past the piston, while still permitting ample lubrication of the cylinder walls. This almost doubles the oil economy. All four rings are "pinned," the bottom one with a separate pin.

42 - What is a "pinned"

ring?

The rings are conventional, but they are "pinned" in position so that they will not rotate and chatter and cause irregular and eccentric cylinder wear. This design further seals the

cylinder against compression loss and oil pumping. Rolls Royce is the only other car in the world using "pinned" rings.



43 - *If the pin keeps the ends of the three upper rings in alignment, what prevents a passage, or "blow-by," of gas and oil at this point?*

The ends of the rings are not in absolute alignment piston rings which they are staggered a small fraction of an inch to prevent an aperture that would permit "blow-by."

"Pinned" piston rings which cannot rotate and cause irregular cylinder wear. The lower ring is "pinned" on the opposite side of the piston.

44 - *Can the pin become loose?*

No. It is peened to keep it permanently in place.

45 - *What is the weight of one Hudson or Terraplane piston and the weight of one iron piston of similar size?*

Hudson piston - 9.6 ounces.

Iron piston - 27 ounces.

46 - *Are silicon aluminum alloy pistons better than ordinary cast-iron pistons?*

Yes. Hudson and Terraplane pistons, weighing one-third as much as iron pistons, greatly reduce vibration tendencies and strain and overload on the connecting rods and crankshafts. They can be fitted more closely, owing to their cam ground design. Thus they hold compression better (saving gasoline and oil), permit higher compression and wear much longer. Also, aluminum is a dissipator of heat; cast iron holds heat much longer. The only

P

disadvantage is to the manufacturer - they are more expensive to make.

47 - Are the wrist pins of the usual type?

No. After being ground, they are "lapped" (held to a variation of 3/10ths of 1/1000th of an inch) to a glass-smooth finish, which assures a permanently close fit. The piston is diamond-bored for the wrist pin. The wrist pins are full floating, meaning that they ride in three bearings (two in the piston, one in the connecting rod), as in very high-priced cars (Duesenberg, Packard, Pierce-Arrow). The full floating design gives better distribution of lubrication, better heat dissipation, prevents seizing, and reduces wear to a minimum. The pin is kept in place by steel lock rings. Pin bushings are bronze.

P

48 - What type and material are the connecting rods?

P "I" beam type of drop-forged special steel, providing extreme rigidity and strength with light weight.

49 - What is the connecting rod length?

$8\frac{3}{16}$ - center to center.

50 - What is the size and type of the lower end bearing?

Width, $1\frac{3}{8}$ "; diameter, $1\frac{15}{16}$. It is of spun babbitt, diamond bored for accuracy and finish.

51 - Are the piston and connecting rod assemblies uniform in weight?

Yes. Pistons and connecting rods are individually weighed and come within exceedingly close limits. The rods installed in any Hudson or Terraplane engine will not vary more than one-quarter of an ounce. The piston assemblies in a motor are uniform to a featherweight balance.

CAMSHAFT AND VALVE ASSEMBLY

5

52 - What type of camshaft is used?

An electric-furnace-hardened shaft of nickel-chrome-molybdenum-iron alloy. *This is as hard as any camshaft material* used by any manufacturer. Hudson was the first automobile manufacturer to use it. Due to its extreme hardness, it can be ground to the smoothest possible surface, permitting a low friction, non-wearing cam nose. P

53 - How is the camshaft driven?

By gears - a cast iron gear on the crankshaft and a laminated bakelite gear on the camshaft. These gears have helical-shaped teeth, are quiet and long lived and do not require adjusting. P

54 - What type of bearing supports the camshaft?

Large babbitt bearings, with surfaces reamed to the dimensions of the camshaft surfaces plus oil clearances. In contrast, some competitive manufacturers support the camshaft in the original cast if on of the cylinder block. The Hudson-Terraplane method, far more expensive, makes for long life and quiet operation. P

55 - What are the camshaft bearing sizes?

Terraplane and Hudson Six -

	Dia.	Length
Front	2"	1 ³ / ₁₆ " (takes end thrust)
Center	3 ³¹ / ₃₂ "	1 ³ / ₁₆ "
Rear	1 ¹ / ₂ "	1 ¹⁵ / ₁₆ "

Hudson Eight -

No. 1	2 ³¹ / ₃₂ "	1 ³ / ₈ " (takes end thrust)
No. 2	2"	1"
No. 3	1 ³¹ / ₃₂ "	1 ¹ / ₄ "
No. 4	1 ¹⁵ / ₁₆ "	1"
No. 5	1 ¹ / ₂ "	1 ¹ / ₂ "

56 - What type of tappet is used?

The roller-cam type, in which the rotating, specially designed cam lobe wipes across the large semi-circular valve-tappet shoe, keeping

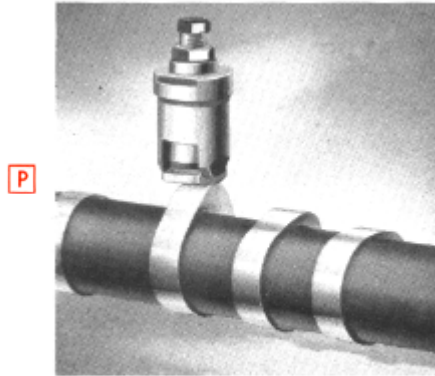

P

Roller-cam tappet in position on cam-shaft lobe.

always in contact with the shoe and giving a roller effect. This constant contact prevents the slapping or tapping that occurs as the cam lobe hits the shoe in the ordinary cam and tappet design. The Hudson design gives precisely

the same effect as a roller tappet. It is longer lived and requires less adjustment than other designs. Because of the smooth roller action and the absence of pounding, less heat is generated and there is less wear and strain.

57 - Has the tappet design been changed for 1937?

P

Yes, slightly. The contour of the shoe has been changed to give a somewhat shorter "dwell" or period of-opening to the valve. This has been done to provide still quieter operation. Reducing the "dwell" would reduce the horsepower slightly, but other changes in 1937 have increased the horsepower so greatly that this slight loss is far more than balanced.

58 - *Is the roller-cam design found in any other car?*

No. This was developed by Hudson and is found only in Hudson-built cars.

59 - *What kind of valves are used?*

Intake valves are special nickel-chromium steel. Exhaust valves are special silicon-chromium-alloy steel. P

60 - *What are the valve head diameters?*

	<i>Intake</i>	<i>Exhaust</i>
Terraplane and Hudson Six	1 ³ / ₈ "	1 ³ / ₈ "
Hudson Eight	1 ¹ / ₂ "	1 ³ / ₈ "

61 - *What is the amount of valve lift?*

1¹/₃₂" on all valves.

62 - *Will the valve spring tension remain constant?*

Yes. The valve springs are specially treated and cadmium plated to prevent rusting and to assure their original tension throughout their life. Cadmium plating prevents rusting. The heat treating prevents fractures of the surface, or "skin", of the wire that would otherwise occur during the stretching action as the spring wire is bent. Valve springs not so treated tend to "soften" after a short period of use. P

63 - *Are the valve springs designed for high speed operation?*

Yes. Valve flutter at high speeds is prevented by specially designed cups which fit over the lower coils of the valve springs, maintaining their alignment at high speeds and permitting perfect action of the spring no matter how rapidly the engine rotates. P

THE FUEL FEED SYSTEM

64 - *What type of carburetor is used?*

P On Terraplane De Luxe models, a single down-draft, with triple venturi. On all other models, a double down-draft, with triple venturi for each barrel. Both carburetors have the delayed deceleration feature.

65 - *What is the advantage of the double down-draft type?*

It gives an increase of more than 10 per cent in power, a gain of 5 to 10 per cent in gasoline economy, and smoother engine performance.

P

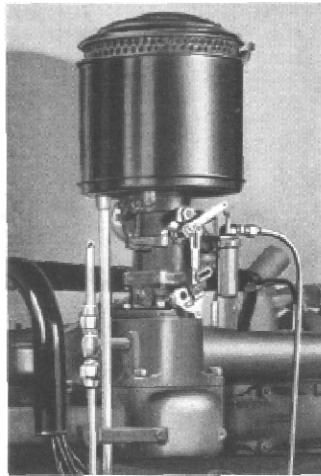

Fuel feed system including double down-draft carburetor, new type radial manifold, automatic choke, vapor-lock relief valve, air cleaner and backfire arrester.

66 - *How is this improved performance accomplished?*

The double down-draft is virtually two carburetors in a single housing. In the 8-cylinder engine, one barrel feeds the front two and rear two cylinders; the other barrel the center four cylinders. In the 6-cylinder engine, one barrel feeds the front three, and the other barrel the rear three

cylinders. Thus each barrel has just half as much work to do as a single-barrel carburetor, although each barrel has considerably more than half of the section area of the single barrel. This means that the necessary amount of gasoline mixture for each combustion charge can be fed into the cylinder at a considerably slower rate, or lower velocity, than with the single-barrel type.

As an exaggerated comparison, it might be said that the double carburetor "floats" the gasoline mixture into the cylinder, while the higher velocity single barrel type must "shoot" in the same amount of mixture. The "floated" charge is more completely diffused and consequently is more completely exploded when ignited. A larger proportion of the gasoline's power is utilized; a smaller proportion is wasted.

This means better performance, because there is more complete combustion—more power is obtained from each engine explosion. It also means better economy, because

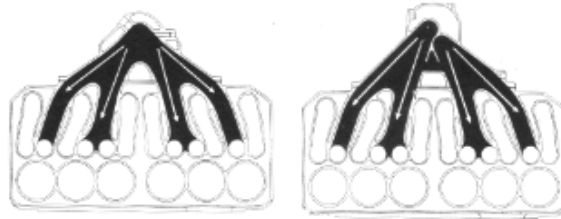

(At left): Plan view drawing of radial manifold for six-cylinder engine with single down-draft carburetor. Note straight passages to cylinders.

(At right): Plan view drawing of radial manifold for six-cylinder engine with double down-draft carburetor. Note straight passages to cylinders. The front three cylinders are fed from one barrel of the double carburetor; the rear three cylinders from the other barrel, permitting the fuel mixture to move at a lower velocity.

67 - *Since the double carburetor has a greater capacity, would it not feed more gasoline into the engine, and thus be less economical?*

P No. Both barrels feed in the same amount in a given time, but do it with less pressure or velocity. As an example, you can fill a gallon bucket with water in one minute, using either a one-inch or a two-inch nozzle ... but you would need a lower velocity with the two-inch nozzle.

If the double carburetor were adjusted to feed more gasoline mixture than is needed for each combustion charge, the engine would not work properly.

68 - *Is the double carburetor difficult to adjust, or will it get out of adjustment easily?*

No more so than the single-barrel type. There is a simple screw adjustment for each barrel. Any mechanic can make the proper adjustment in a few minutes.

69 - *Is the double carburetor actually two carburetors in one?*

There is a single float bowl, but in all other respects the parts and operation of each portion are distinct.

70 - *Do most 6-cylinder engines have a double carburetor?*

No. Terraplane Custom and Hudson Six models are the only American 6-cylinder cars with this type. Others can't use double carburetors because their type of manifolding will not permit it.

71 - *Why is the delayed deceleration type of carburetor used?*

D So that deceleration will be smooth, rather than abrupt, when the driver's foot leaves the accelerator.

72 - Is the fuel heated in any manner to assist carburetion?
 Yes. Exhaust gas from the rear cylinders is taken from the exhaust manifold and carried around the intake jacket to heat the fuel before it passes through the intake manifold. P

73 - Is there thermostatic control of this for summer and winter driving?
 Yes, on all series except Terraplane De Luxe, which has manual adjustment. P

74 - Do Hudson and Terraplane carburetors have air cleaners and silencers?
 Yes. They are standard on all models. Further, they have a flame arrester, an important safety factor. D

75 - How is gasoline supplied to the carburetor?

By a newly designed and larger fuel pump, driven by the camshaft. The diaphragm is larger than in 1936 and there is a larger exposed glass bowl instead of a smaller metal bowl. It has a maximum flow of 40 gallons an hour, compared with 18 gallons for the 1936 pump. This means that it exerts constant pressure on the flow to the carburetor. These changes have a very important cooling effect on the pump, and also prevent vapor lock at high temperatures.

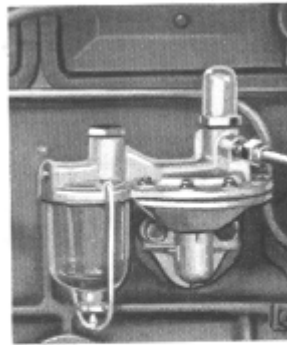

The new and enlarged fuel pump, with exposed glass sediment bowl.

76 - Is the vapor-lock relief valve at the float chamber retained?

Yes. When the engine is stopped, the residual heat sometimes causes part of the gasoline in the float chamber to vaporize. This vapor tends to "lock" fluid gasoline from the jet, and must be removed to let the fluid fuel through before the motor can be restarted. Normally, it would be necessary to suck the vapor slowly through the jet by prolonged use of the starter, but the new vapor-lock relief valve opens automatically when the accelerator is released, and permits the vapor to escape quickly.

77 - What type of intake manifold is used?

The "radial" low-velocity type, in which large straight passages to the cylinders radiate from the distributing chamber as spokes from a hub. This permits "easier breathing" and better combustion.

For the Terraplane Custom and all Hudson engines, the manifold has been redesigned to work with the double carburetor. There is a distributing chamber for each end of the manifold.

78 - What are the advantages of the radial type manifold?

Uniform, straight-path distribution of the fuel mixture to all cylinders, resulting in uniform power impulses and smoother performance.

79 - Can liquid gasoline collect in the intake manifold and interfere with combustion?

No. In 1937 there is a drain valve that is open as long as there is no vacuum pull from the cylinder, and that lets fluid gasoline drain off through a pipe that extends below the bottom of the engine.

80 - *Is automatic choke used?*

Yes. It is standard on all series except Terraplane DeLuxe, which has manual choke.

81 - *What are its advantages?*

It automatically makes the proper mixture adjustment for starting, and then automatically changes the adjustment for continued driving. Choking is controlled entirely by the temperature of the carburetor and vacuum in the intake manifold. Nothing is left to human neglect or forgetfulness. When the choke is not operating, part of the clean warm air is diverted directly to the fuel stream in the manifold, further aiding in atomization. There is a special relief valve that operates in the event of back-fire. This is an important safety factor. P

82 - *Has the automatic choke design been changed?*

There are minor changes, to adapt it to the new double carburetor.

83 - *Can the automatic choke valve become stuck?*

No. The cam-and-rod design assures the opening of the choke when the engine is started. In cold weather, the contraction of metal parts sometimes caused the choke valve to stick when the car had been standing for some hours and, as it might not open immediately when the engine started, it would cause flooding of the carburetor and consequent stalling. With the cam design, the valve is pushed open by pressing well down on the accelerator. P

84 - *What is the gasoline tank capacity?*

16½ gallons in all Hudsons and Terraplanes.

ELECTRICAL SYSTEM AND STARTER

85 - *What type of generator is used?*

A newly designed high-output, fan-forced ventilation type, known as the GCJ model. In Terraplane De Luxe models (unless equipped with radio), the maximum charging rate will be 16 amperes.

P

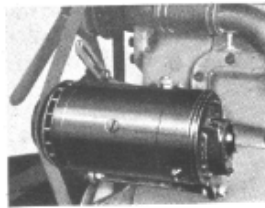

The new high-output generator with fan-forced ventilation. The voltage regulator is mounted on the front side of the dashboard underneath the hood.

All other models (and Terraplane De Luxe models with radio) will also have a voltage regulator and the generator will be set with a charging rate of 2.5 amperes. When a radio is installed in the field in a Terraplane De Luxe model, the voltage regulator can also be installed and the charging rate increased.

86 - *Is the generator improved in any other ways?*

Yes. The commutator is longer, providing more brush contact area and increasing brush and commutator life.

P

There is also a new type of brush holder which keeps the brush in constant contact at the highest speeds, also lengthening brush life. The end frames of the generator are now of cast iron, to maintain the alignment of the brushes and eliminate generator noise.

87 - *Has the voltage regulator been improved?*

Yes. Previously the regulator was a "two-charge" type, meaning that it could regulate the generator to only two charging rates - a high rate when the battery's voltage got

below a predetermined point, and a low rate when the voltage got above another predetermined point; This meant a continual fluctuation in battery strength between these high and low points, and there was also the possibility that the high charging rate would cause overheating in the generator.

P

In 1937, the vibrator type of regulator is used. It does not regulate to merely two rates, but is "elastic", meaning that it increases the charging rate gradually as the battery's voltage drops; and as the voltage increases, the charging rate tapers off so that only a small amount of current flows into the battery when it is fully charged. This prevents overcharging, protects both the battery and the generator, and assures an ample battery charge, regardless of drain by excessive use of radio, starter and other electrical units.

88 - *At what speed does the generator reach the maximum charging rate?*

At 28 miles per hour.

89 - *How is the generator driven?*

By a V-belt. An adjustable bracket permits proper belt tension at all times.

90 - *What type of starter is used?*

A finger-touch starter. The weight of the driver's finger on a conveniently located button on the instrument board actuates the 6-volt solenoid operated switch, which in turn actuates the over-size starting motor. A Bendix drive is used. There is a manual button at the starting motor for emergency or "under hood" operation. With the Electric Hand installation, the clutch pedal should be depressed when the starter button is touched.

91 - *How is the starter bearing lubricated?*

P An oiler provides constant and ample lubrication.

92 - *What size are the batteries?*

Terraplane and Hudson Six-105 amp. hour, 17 plates (full size); Hudson Eight-125 amp. hour, 19 plates (full size).

93 - *Are these heavy-duty batteries?*

Yes; they are standard batteries with a very high plate area. Consequently they have a high current flow for cranking the engine in extremely cold weather. The additional capacity of these batteries provides a store house for the extra generating capacity of the large 1937 ventilated and cooled generator.

94 - *Where is the battery located?*

In a box under the left hand side of the hood, at the side of the chassis frame. In this convenient and accessible position it is

S not necessary to disturb any passengers when testing or refilling battery.

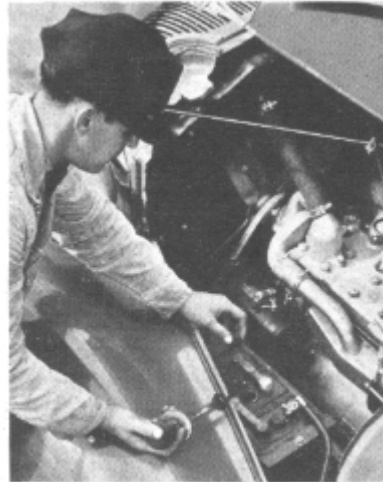

The battery is located conveniently under the left side of the hood.

95 - What type of spark advance is used?

Full automatic, for maximum efficiency at all speeds.

96 - What type of spark plugs are used?

14-millimeter spark plugs. Hudson was the first manufacturer to adopt metric plugs as standard equipment. A feature of the plugs is the sealing of the interior of the plug with sillimanite to prevent compression and oil leaks through the plug. These leaks would cause oil to pocket at the firing end of the plug, resulting in carbon deposits and fouling.

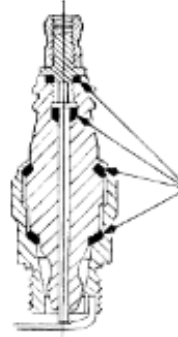

P

97 - Why is the single-lever ignition breaker used?

It is equally as efficient as the two-lever type and does not require occasional synchronizing adjustments, as does the two-lever type. Consequently, it is a sturdier and more satisfactory design.

*Cross-section
of spark plug,
showing Silli-
manite Seal*

OILING SYSTEM

98 - What is the function of a motor oiling system?

To provide a lot of oil to all bearings and other friction surfaces at all times, whether the motor is cold or hot, running fast or slow, or on a level plane or an angle.

P

99 - What type of oiling systems do Hudsons and Terraplanes have?

The Duo-flo system, patented by Hudson and available in no other cars.

P

100 - How does the Duo-flo system get oil to the various bearings and friction parts?

See the illustration and description on pages 72 and 73.

DUO-FLO OILING SYSTEM IN HUDSONS AND TERRAPLANES

Note: Solid darker red indicates fluid or flowing oil. Solid lighter red indicates an oil film on friction surfaces, such as cylinder walls and bearings. Mottled red indicates the oil spray enveloping the moving parts in the crankcase and engine block.

Cool, cleaned oil is sucked up through the pipe (A) to the big, double-action oil pump (B), which then pumps the oil through two pipes—one leading to the front of the engine and the other to the rear; note the direction of the arrows in the pipes leading from the oil pump.

Oil from the front pipe (C) pours over the front-end gears, keeping them continually bathed in lubricant. This oil then flows through the lower duct into the No. 1 trough (D) in the oil tray.

As the No. 1 piston goes down and the crank pin reaches the bottom of its rotating travel, the finger, or scoop (E) at the end of the connecting rod swishes through the No. 1 trough in the oil tray, throwing a spray of oil clear up through the crankcase (note speckled red area).

Part of this spray coats and lubricates the cylinder wall. Part of it collects in oil holes (F) at the piston assembly and lubricates the wrist pin. Part of the spray coats the camshaft faces and provides constant lubrication for the camshaft and tappet contact (G). Part of it coats the valve stem and lubricates it for its travel in the valve-stem-guide (H).

Part of the oil spray collects on the upper crankcase surfaces and then runs down into oil reservoirs (I) over the camshaft bearings, providing them with a constant supply of oil - a supply that is already there and waiting when the engine is started. Still another portion of the oil spray collects on the side wall of the crankcase, then runs down and is caught by the channel (J) that carries it to oil reservoir (K) over the main bearings, giving them an abundant supply of oil at all times - even for the first turn of the engine.

The finger, or scoop, at the end of the connecting rod has a hole drilled upward to reach the connecting rod bearing, and oil is forced directly to the bearing each time the scoop travels through the oil trough. Thus the bearings always have a full supply of cooled oil.

A baffle, or guide-plate (L), at the end of the No. 1 trough catches much of the oil that is thrown by the scoop against the crankcase wall above it, and directs it into the No. 2 trough. Similarly, the oil is directed from the No. 2 trough into the No. 3. From the No. 3, it flows through a return duct into the oil pan below.

In the same way, oil flows from the No. 6 trough at the rear of the oil tray into the No. 5, and then into No. 4, and then through the return duct into the pan below.

When the oil has returned to the oil pan, it flows through a winding series of baffles (see illustration on page 76), reducing the oil temperature by 45 degrees. This cooling is caused by the air passing along the bottom of the oil pan. After flowing through this labyrinthian passage, the cooled oil passes through a filtering screen (M) that thoroughly cleans it, and flows into the sump (N). From here, it is sucked up to the oil pump and the circuit around the lubricating system is repeated.

The Terraplane engine Duo-flo oiling system is illustrated here. The Hudson Six engine is exactly the same. The Hudson Eight system is the same, except that there are eight troughs in the oil tray, and the channels at the side of the crankcase are designed to carry oil to the five main bearings.

The Duo-flo system, which is exclusive on Hudsons and Terraplanes, is the only oiling system that supplies a large flow of cooled oil to all parts of the engine at all times, whether the engine is running fast or slow, hot or cold, on a level plane or on a hill.

DUO-FLO OILING SYSTEM—SIDE VIEW

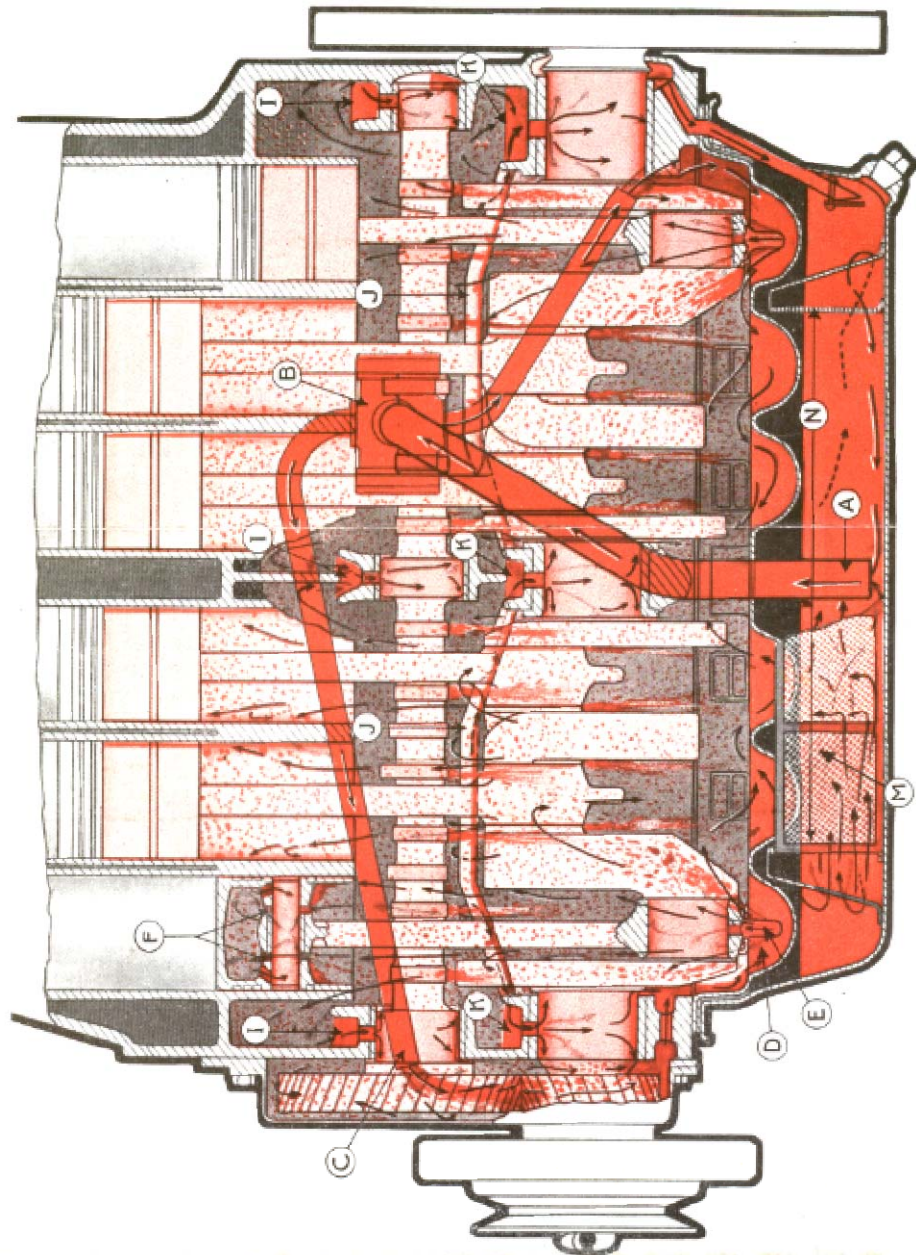

END VIEW

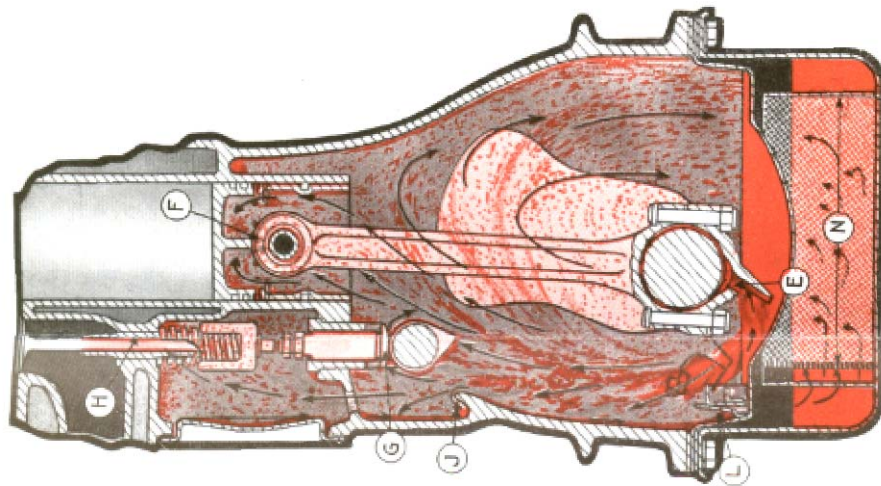

101 - Why is the system called Duo-flo?

P Because the oil flows in two large streams. The double pump delivers the oil to both ends of the motor, from which the streams flow to meet again in the middle, thus circulating twice as as was previously possible.

102 - What is the advantage of such a large flow of oil.

The big rivers of oil easily soak up and carry away all of the heat of the bearings, whereas a small stream of oil entering the bearings neither cools the bearings nor stays cool itself, and often requires a separate cooling system. Instead of

P squirting a little hot oil on a bearing, the Duo-flo system pours a lot of cooled oil over it. Because oil in a pressure system is almost always hot, it must be forced through the system to enable any heat to be carried away. The large oil flow provided by the Duo-flo system prevents connecting rod and main bearing trouble and other costly service work.

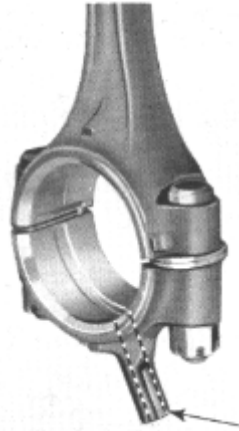

Oil "scoop" or "finger" on connecting rod lower end. Dotted line indicates hole through which oil is fed directly to the crank pin bearing.

103 - Is the oil cooled and cleaned at any point?

P Yes. When the oil returns to the pan, it must flow through labyrinthian passages (a winding series of baffles) before it passes through the filtering screen into the sump, from which it is again drawn up by the

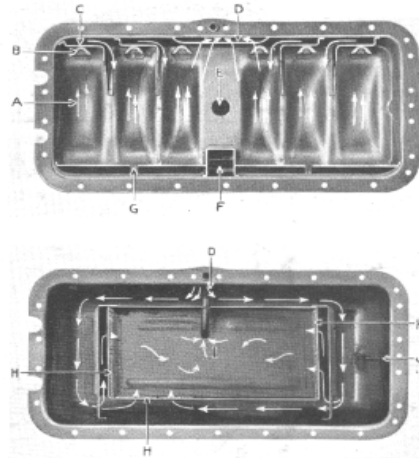

Views looking down into oil tray (above) and oil pan (below)

Oil Tray: A - White arrows indicate direction in which oil in the troughs is scooped up and thrown by the scoop on the connection rod. B - The "vaporizer" a small cup, or baffle, which catches part of the oil thrown by the scoop and breaks it up into a fine mist, or vapor, that fills the entire crankcase. C - The baffle-plate that directs oil into the next trough toward the center of the tray. Oil thrown against the crankcase wall by the No. 1 connecting rod runs down and is thus directed into the No. 2 trough. Note that similar baffles at the end of each trough direct the oil toward the center of the tray. D - The duct through which oil, running down the crankcase wall, passes into the oil pan below, E - A filter-screened over-flow hole through which oil may flow into the pan below. F - The hole through which the bayonet, or measuring-stick, passes into the pan. G - Baffle

plates on this side of the tray catch the oil running down the crank-case wall and direct it back into the tray.
Oil Pan: D - Oil coming down from the oil tray through the duct (see D above) enters the oil pan here and follows the course of the white arrows, around the labyrinthian passages. H-H-H - Filtering screens through which oil passes into the sump. I - The sump, in which the oil circulates until being drawn up through the pipe to the oil pump. J - The pipe that returns excess oil from the rear-end bearing oil-reservoirs.

pump. During this devious flow through the pan, the temperature of the oil drops 45 degrees due to the cooling effect of the air passing beneath the car.

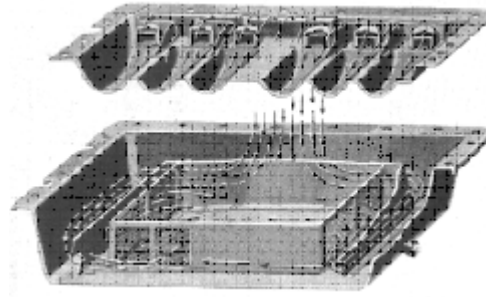

Cut-away perspective view of oil tray (above) and oil pan, showing their relative positions, Arrows indicate how oil moves in the tray, then flows down into the pan and around the labyrinthian passages.

104-Can the flow of oil ever fail with the Duo-flo system?
 No. Not if there is oil in the oil pan. And the Teleflash oil gauge on the instrument panel gives warning of an oil shortage. The double pump is absolutely valveless, and has no adjustments or by-passes. It works when the engine works, and always works the same. Inside the engine, the distribution of oil is controlled by gravity, a force that will

P

never change and never fail.

105 - Does the Duo-flo system provide adequate lubrication on a cold day?

Yes. It is the only system that gives positive lubrication from the instant of starting. The oil is ready where it is needed at the first turn of the motor ... no waiting for thickened, sluggish oil to be forced through small apertures to point of friction. P

106 - Is a "forced-feed" system more positive?

Oil cannot be forced into a bearing. The space to be lubricated between a bearing and its journal is approximately .001" in thickness, and thousands of

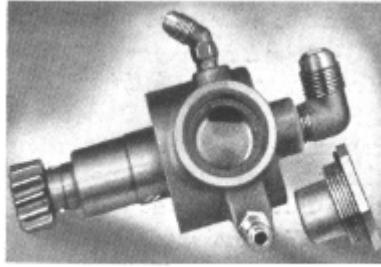

Large double action, valveless oil pump.

pounds of pressure would be required to force oil into this space. The pressure of an automobile oil pump is only about forty pounds. The "forced-feed" system is so named because it forces oil through small holes and pipes to a point outside of the bearing. The Duo-flo system pours much larger quantities of oil to the same point. The oil is then pulled, or sucked, into the small spaces by the capillary action of the moving parts. The pressure of this action is many times greater than that of any oil pump. All that any oiling system can do is to carry the oil to a point outside of the bearing. The moving bearing then does the lubricating.

107 - Has the Duo-flo system any other advantages?

Yes. It has no small passages to become clogged with dirt, oil sediment or abrasive particles.

It stirs up the oil, vaporizing the water and acid (foreign matters in the oil) so that they pass off through the ventilators.

P If a bearing becomes loose and takes an excess of oil, it does not rob the other bearings of their oil quotas, as is true with the forcefeed or pressure system. A loose bearing would get all of the oil it could use with the Duo-flo system.

108 - Is the Duo-flo system long lived?

P Yes. It is absolutely the only system that will be working exactly the same after 100,000 miles.

109 - Does it make any difference whether the Hudson or Terraplane is on a hillside?

P Absolutely not. The Duo-flo system functions perfectly regardless of the angle of the motor. The troughs in the upper oil tray retain oil wherever it is needed along the full length of the motor.

110 - What is the refill capacity of the oil pan?

Terraplane and Hudson Six - 5 quarts; Hudson Eight - 7 quarts.

111 - How often should the oil be changed?

For the best results, it is recommended that with normal driving and the use of a good grade of oil, it be changed at each 2000 miles. However, if an owner prefers to change oil more frequently, he is taking a precaution toward the longest life and best service possible for the engine.

COOLING SYSTEM

112 - How much water does the system hold?

Terraplane and Hudson Six - 12½ quarts; Hudson Eight - 20 quarts.

113 - What kind of circulating system is used?

5

Pressure circulation. A thermostatic valve at the front of the cylinder head causes the water to return immediately through a by-pass to the engine until the water has reached the engine temperature; then the thermostat causes the water to flow in the normal manner through the radiator (for cooling) before returning to the engine. (This thermostatic valve is in all models except the Terraplane De Luxe.)

P

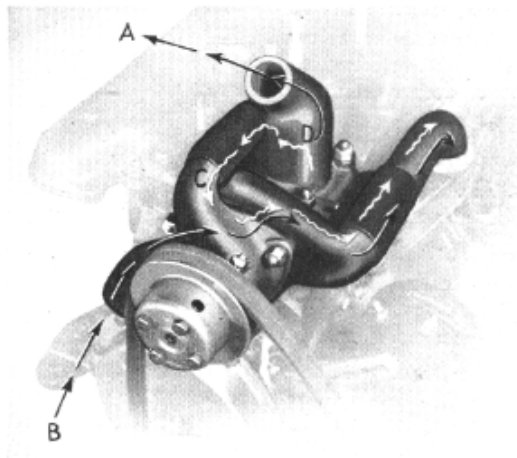

Water pump and water circulating system. Wavy white lines indicate direction of flow until water reaches engine running temperature, thermostatic valve (at D) directs water from cylinder block through by-pass (C) and directly back into the engine. The black lines indicate the normal circulation after the water has reached engine running temperature; the thermostatic valve (D) opens to permit the water to run to the radiator (indicated by A); after passing through the radiator and being cooled, it is brought back (B) through the water pump and pumped by pressure through the engine.

114 - *Have any changes been made in the cooling system for 1937?*

P Yes. In the Hudson Six the radiator has been moved back a few inches closer to the engine, to increase the effectiveness of the fan and improve cooling. The radiator now rests on a special frame cross member, which also serves further to strengthen the frame. In all models, the radiator is now in the same relative location to the engine.

115 - *Why is the thermostatic valve in the cylinder head?*

P The closer it is to the engine block, the faster the circulation during the warming up period of the engine and the shorter the warming up period.

116 - *Does this faster beating of the water affect the car heater performance?*

Yes. The Hudson-designed heaters will begin throwing heat into the car almost instantly.

117 - *What is the advantage of the pressure system?*

P It provides rapid, positive distribution of water in much greater volume. The circulation is 30 gallons per minute at approximately 50 miles per hour.

118 - *If a pressure water system is best, why not also a pressure oiling system (see Question 106)?*

In a pressure oiling system, the oil passages are so small that only a small stream of oil can be circulated . . . too small a stream to carry off the heat most efficiently . . . whereas the water passages are large and the pressure pump can force a large stream of water through the engine rapidly.

119 - *Is the pump trouble-free?*

P Yes. No packing adjustment is required, as the pump is automatically and permanently self-sealed at the shaft

and housing by a spring-loaded, graphite-impregnated cork ring. The thrust is taken by spring-loaded stainless-steel washers that are machined and ground.

120 - *Is there a water temperature indicator?*
Yes, in all models.

D

121 - *What type of fan is used?*

A sturdy, four-blade fan, with scientifically pitched blades for uniform distribution of the air current. It is driven by a V-belt.

P

SELECTIVE AUTOMATIC SHIFT

122 - *What is the Selective Automatic Shift?*

It is an exclusive Hudson and Terraplane feature, consisting of a combination of the Electric Hand and the new and improved automatic clutch.

123 - *Is this the same as an automatic transmission?*

No. It is much better, because with the automatic transmission, the driver has no control whatever over the gear in which the car is operating; the gear is selected automatically by the speed of the car or the driving torque. There are certain driving conditions, such as steep grades, where it is important for the driver to select the gear, as he can with Selective Automatic Shift.

P

124 - *How is the combination of Electric Hand and automatic clutch different in 1937?*

Principally through a major improvement in the automatic clutch-the development of a governor that permits the automatic, or coasting effect of the automatic clutch only at speeds up to 15 to 18 miles per hour. The automatic, or coasting, effect is highly desirable at lower speeds, especially for city driving, but is not desirable at higher speeds

D

and in open-country driving where the braking effect of the engine is needed. When the car is accelerating, the governor permits the coasting effect in low and second gears re-

gardless of car speeds (for example, if the car is accelerated to 30 m. p. h. in second gear, the automatic operation is still in effect); but in high gear the coasting effect is automatically cut out as the car speed passes 15 to 18 m.p.h. (if, for example, the

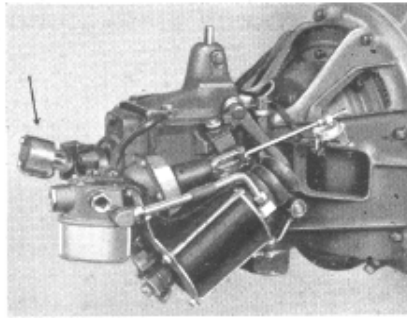

P

D

Hudson's Selective Automatic Shift mechanism: the synchro-shift transmission, the vacuum-powered gear-shifting unit (Electric Hand control), and the new coasting governor (arrow points to governor).

car is traveling at 30 m.p.h. when the shift is made from second to high gears, the automatic operation is cut out the instant the shift is made). When the car is decelerating from higher speeds (for example, 40 m.p.h.) in high gear, there is no automatic operation until the car has slowed down to about 18 m.p.h. If the driver shifts back into second or low gears, the coasting is again, of course, in effect.

125 - Is the Selective Automatic Shift standard or optional?

Optional at a nominal extra cost. The Electric Hand and automatic clutch units are also optional separately at nominal extra costs.

126 - *Is the Selective Automatic Shift complicated?*

No. It is very simple to drive, and is also simple in design, so that it will not cause service troubles. In contrast, the various types of automatic transmission are very complicated in design and generally subject to service troubles. There is little difference in the amount of effort required of the driver. With the Electric Hand, he shifts gears easily with a flick of the finger. With automatic transmissions he must put the transmission in gear when he starts the car, must put it into reverse and back into a forward speed each time he wishes to change his direction, and must also throw the automatic device out of use if the braking effect of the engine is desired when (for example) going down a hill. The ability to throw the automatic device out of operation is not incorporated in all automatic transmissions, but when it is operated, it causes considerable strain on the mechanism.

D

127 - *Do other manufacturers offer Selective Automatic Shift?*

No. Since Hudson's exclusive oil-cushioned clutch is the only clutch that has a sufficiently smooth and non-grabbing action to permit satisfactory use of automatic clutch operation, it is unlikely that other manufacturers will ever be able to offer Selective Automatic Shift.

128 - *What is the "Electric Hand?"*

It is a gear shifting development with pre-selection feature, in which the work of shifting is done with vacuum power.

129 - *How is it operated?*

Pre-selection means that the next gear into which the transmission is to be shifted can be chosen any length

D

of time in advance of the actual shifting. It is done in this manner: An arm extends out from the steering column, immediately under the normal position of the driver's right hand on the steering wheel. Extending up from the end of this arm is a small lever or trigger easily reached by the fingers of the driver's right hand. While running in any gear, the driver can move the lever through an H (similar to that of the conventional gearshift) to pre-select the next gear in which he wishes to travel. When the driver is ready to shift gears (if his car is equipped with automatic clutch) he takes his foot momentarily from the accelerator and the shifting is accomplished by vacuum action; if the car does not have automatic clutch, the driver presses the clutch pedal and this actuates the shift.

130 - What are its advantages?

1. Its simple operation is much less fatiguing than manipulating a gearshift lever.

P 2. The driver need never take his hand from the wheel or his eyes from the road to shift gears-a safety factor.

D
S 3. He can anticipate his shifting requirements and is not compelled to reach hastily for his shift-lever in an emergency.

4. Eliminating the gearshift lever makes the front compartment clear, much roomier and more convenient - see illustration on page 132-(the emergency brake is under the cowl at the left-hand side in all Terraplane and Hudson models).

131 - *Has any change been made in the Electric Hand in 1937?*

Yes, there is a slight change in the shift position on the control unit. Instead of moving the small control lever in a true H, as before (lifting the lever to permit the movement into reverse gear), the reverse gear movement angles to the left. This was done to make the



A change in the H design in the Electric Hand control makes shifting into reverse easier and simpler.

movement more obvious to persons who are unfamiliar with the Electric Hand and who might, through ignorance of the operation, try to force the lever into reverse without lifting it, and thus bend or break the lever. Shifting into reverse will also be easier with the new design.

132 - *Can the conventional gearshift be used if the "Electric Hand" is installed?*

Yes - the gearshift lever can be attached in a few seconds, and the transmission operated in the conventional manner.

THE CLUTCH

133 - *What type of clutch is used?*

- P** A single-plate, cork-insert, oil-cushioned, triple-sealed clutch. This is the smoothest engaging type of clutch

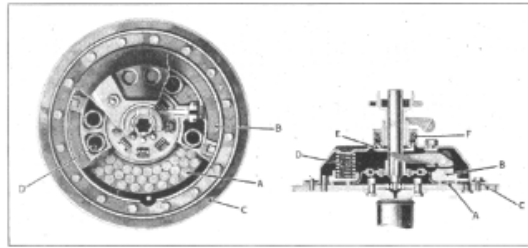

Cut-away view of Hudson's exclusive triple-sealed oil-cushioned clutch. A - Aluminum friction plate, with treated cork inserts. B - Drop-forged steel pressure plate, C - Light-weight steel flywheel. D - Heat-treated spring. E - Throw-out bearing. F - Oil seal.

known, being entirely free from chatter and grab, and is unusually long lived.

134 - *Why is cork used as a friction material?*

- P** Its co-efficient of friction is higher than that of any other known material. When used with cushioning oil, it is very long wearing. It does not disintegrate from the effects of the oil as does other clutch lining material, and provides smooth clutch engagement.

135 - *What is the advantage of oil-cushioning?*

- D** Lubricated working parts mean longer life and an oil cushion provides the smoothest initial engagement known. Clutch grabbing, which results from dry surfaces, is eliminated.

136 - What is meant by "triple-sealed" clutch?

The Hudson and Terraplane clutch is (1) sealed in front - a leather-sealed throw-out bearing; (2) sealed around the perimeter, against centrifugal action of the oil; (3) sealed at the rear, against leakage. The cushioning oil is retained for exceptionally long mileages, and the minimum of attention is required.

P

137 - How many cork inserts are there?

Terraplane	90	Hudson Six	90
		Hudson Eight	108

138 - Will the cork inserts become loose, come out or wear out?

They will remain firmly fixed in the friction plate, and will wear for an extraordinarily long period. After being inserted in the plate, the corks are spread and fixed in oil under pressure, and heat treated for period of one hour. After this they are cooled in oil and trimmed to a limit of .001".

P

139 - Is the pressure plate made of cast iron, as in other cars?

No. It is of forged steel, exactly the same as the material in the front axle. This expensive material is used because of its strength and uniformity.

P

140 - With the clutch springs "soften" after brief use, as they do in other cars?

No. They are "pre-set" by special treatment to prevent softening during use. This assures retention of the clutch's operating characteristics throughout its life and saves service adjustment.

P

141 - *What is the clutch cover design?*

P It is heavily ribbed for increased rigidity, with ample openings for ventilation.

142 - *Is the flywheel made of iron as in other cars?*

P No. It is made of steel, for lightness and strength. The ring is heat treated and the flywheel is ground and polished, and perfectly balanced. It provides the best contacting surface for the clutch yet devised. It is approximately only half as heavy as the iron flywheels used in competitive cars, and consumes 50% less power from the motor.

143 - *What kind of fluid is used in the clutch?*

P For the smoothest possible service, Hudsonite Clutch Compound, an inexpensive fluid developed by Hudson engineers, is recommended. It may be obtained from all Hudson and Terraplane dealers and service stations.

144 - *Do other cars have this type of clutch?*

No. It has been developed over a period of twenty years by Hudson engineers, who have concentrated on this one type of design and have brought it to its present high peak of efficiency.

145 - *Is free wheeling available?*

All the advantages of free wheeling, with none of the usual disadvantages, are provided with automatic clutch available on Hudsons and Terraplanes.

TRANSMISSION

146 - *What type of transmission is used?*

A synchro-shift, three-speed transmission, with silent second

gear. Low and reverse gears are automatically demeshed when second and high gears are engaged, or when the transmission is in neutral. This feature lengthens the life of the transmission and makes it quieter in operation. The synchro-shift, non-clashing transmission, rapid and positive in its action, is an important factor in Hudson and Terraplane super-performance.

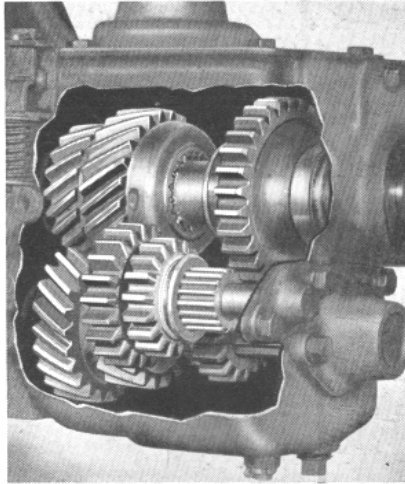

Cut-away view of synchro-shift transmission (left side) without Electric Hand installation.

5

P

147 - What are the transmission gear ratios?

High	1 - 1	Low	2.424 - 1
Second	1.61 - 1	Reverse	2.99 - 1

148 - Of what material are the gears made?

Nickel molybdenum electric furnace alloy steel. The constant mesh gears are of electric furnace steel, the most expensive of all automobile steels. The Terraplane is, as far as is known, the only car in its price class using this steel.

P

149 - *Are the transmission bearings adequate?*

P Yes. For added safety and durability, there is a multiple ball thrust between the main stem gear and the main shaft. This provides great oversize beafing capacity to take cafe of the load at this point. Also, needle bearings carry the front end of the main shaft.

150 - *Can any gear become disengaged when the car is passing over rough roads?*

D No. Two transmission "interlocks" prevent this. The clutch pedal must be depressed if gears are disengaged in any speed.

STEP NUMBER TWO

6

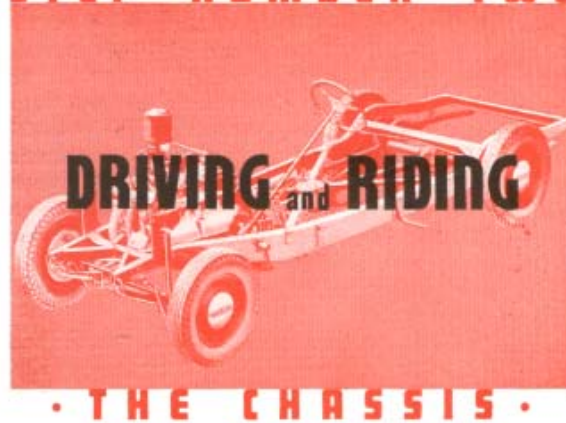

THE story of Hudson's development of the automobile is a romance of leadership of the industry. With the introduction of the first Hudson-built car back in 1909, the Hudson Motor Car Company won a reputation for building cars to last. Actual owner records show Hudson-built cars with 150,000 . . . 200,000 . . . 250,000 miles or more . . . still going strong. Never satisfied with laurels already won, Hudson engineers have main tained a never-ceasing search for improvements and refinements.

The result has been a succession of Hudsons and Terraplanes that drove easier, rode better and lasted longer than cars costing hundreds of dollars more. Little wonder, then, that public acceptance of our line has grown so steadily.

In 1937, Hudson and Terraplane offer, exclusively one

of the greatest advancements in driving that the industry has ever seen-Selective Automatic Shift.

Selective Automatic Shift achieves the highest point of perfection in gear control yet obtained. A flick of the finger ... a touch of a toe ... to shift ... to stop . . . to go. It is as simple as that. It lets the driver do the thinking but the car does all the work. Selective Automatic Shift has all the advantages of an automatic clutch without the disadvantage of free wheeling at high speeds. The driver selects gears with the Electric Hand, then with a touch of a toe to the accelerator, gears shift smoothly and silently at any car speed and at any engine speed.

Double Drop "2-X" Frame, is longer, wider, deeper and stronger than ever. It permits a lower center of gravity, 1½ inches lower, with the same road clearance as the 1936 cars. This rugged frame is both riveted and welded and is further strengthened by the "box" construction of its members. Finally, the frame is bolted to the body in 38 places instead of the usual 10 to 12. Thus the frame and the body become a single unit.

Hydraulic Hill Hold prevents roll back when starting on hills. It is connected to the hydraulic brakes and operates from the clutch pedal, leaving the right foot free for the accelerator pedal and making starting easier on grades. It is not in operation when the car is in motion, when it is level or when the front end is lower than the rear.

In addition to these sales-making features, all Hudsons and Terraplanes have Duo-Automatic Hydraulic Brakes, Radial Safety Control, Tru-Line Steering, Rhythmic Ride and Road Leveller Shock Absorbers. Every one of these advancements was pioneered by Hudson. Four of these advancements are available in 1937 only on Hudsons and Terraplanes.

THE HUDSON EIGHT CHASSIS

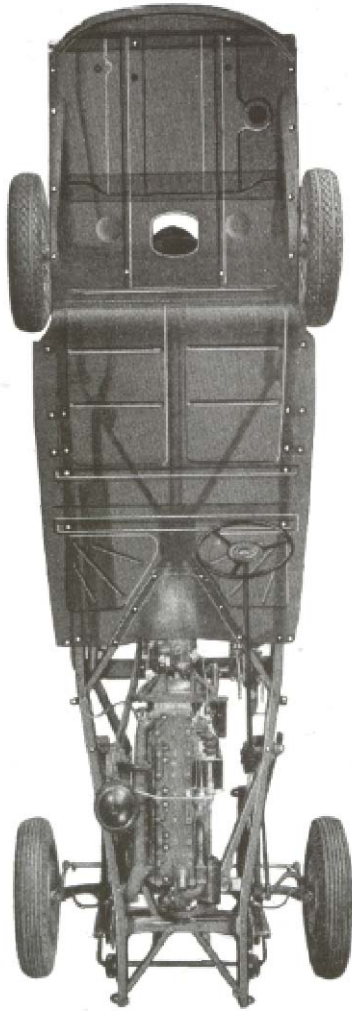

Plan view illustration of Hudson chassis showing (in phantom) the sheet steel panel, heavily trussed and ribbed, that serves as both chassis cross member and body floor. Note 38 points, indicated by white dots, where chassis and body are bolted together into a unified whole.

**HUDSON-BUILT CARS for 1937
are THREE BIG STEPS AHEAD in**

- P** -PERFORMANCE, including Economy
- D** -DRIVING and RIDING, including Safety
- S** -STYLE and COMFORT

Every part in Hudson-built cars contributes to one of more of these superior qualities. In reading the following pages, note the symbols in the margin beside the answers. They point out why Hudson built cars are ahead in each of the three big and important values.

**CHASSIS
QUESTIONS AND ANSWERS**

151 - *What are Hudson and Terraplane wheelbases?*

Terraplane	117"
Hudson Six	122"
Hudson Eight (Sedans, Broughams, Coupes, Convertible Coupes, Convertible Broughams).	122"
Hudson Eight (Sedans)	129"

152 - *What are the over-all lengths (bumper to bumper, including bumper guards)?*

Terraplane	194½"
S Hudson Six	199"
Hudson Eight (122" wheelbase models)	199"
Hudson Eight (129" wheelbase Sedans)	203 ³ / ₁₆ "

153 - *What is the tread?*

	<i>Front</i>	<i>Rear</i>
D All Hudsons and Terraplanes	56"	57½"

154 - Has any change been made in the frames in 1937?

Yes. The 1937 frames are double-drop type, with 2 X-members, and with box-section side-rails extending virtually the full length of the frame. The frame is both riveted and welded, there being 142 welds, most of them in the box-section construction. Although the frame section depth of Hudsons and Terraplanes was already greater than in other cars in their price fields, the section depth has been increased by $\frac{1}{2}$ inch in Terraplanes and by $\frac{3}{8}$ -inch in Hudsons. The frame

Cross section drawing of Hudson frame box section, at a point just in front of steering post connection where strains on steering assembly are most severe; actual measurements are indicated.

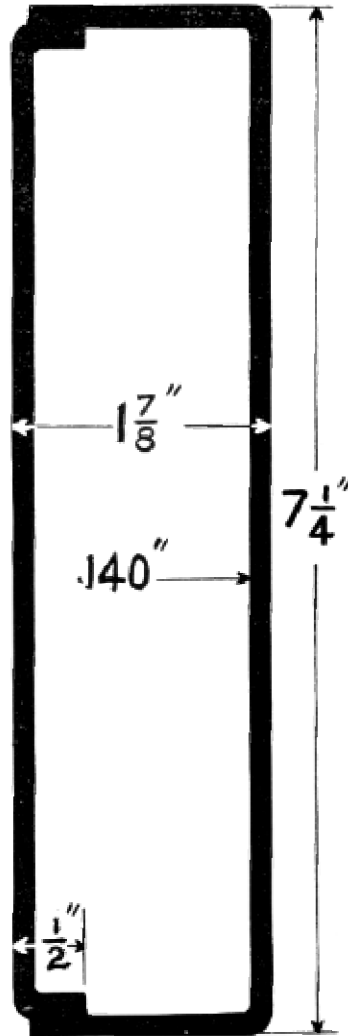

is probably 200 per cent stronger than any ever previously used in Hudson-built cars. Hudson was the first manufacturer to use the box-type member, and this greater experience is reflected in the new design. To accommodate the new wider bodies, the frame side-rails flare outward toward the rear, giving a maximum greater width of 6 inches.

D 155 - *What is the maximum depth of the frame?*
 Terraplane $7\frac{1}{4}$ " Hudson $7\frac{3}{8}$ "

D 156 - *What is the width of the flange?*
 Terraplane $1\frac{3}{4}$ " Hudson Eight 122" w.b. $1\frac{25}{32}$ "
 Hudson Six $1\frac{25}{32}$ " Hudson Eight 129" w.b. $1\frac{31}{64}$ "

D 157 - *What thickness of steel is used in the frame?*
 Terraplane $\frac{7}{32}$ " Hudson Eight 122" w.b... $\frac{1}{8}$ "
 Hudson Six $\frac{1}{8}$ " Hudson Eight 129" w.b $\frac{9}{64}$ "

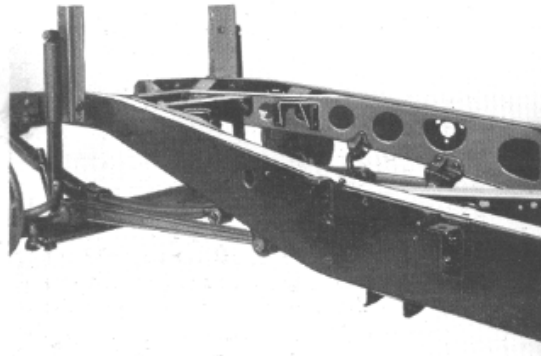

Front end of frame showing deep box section and sturdy cross members, giving extreme rigidity. (Note torque rod from frame to front axle; see question No. 162)

158 - *What portion of the frame side rail is deepest and strongest?*

The section between the "X" member and the rear end of the front spring. This is portion made stronger because it is the point of maximum stress from road shock. The fact that the maximum depth section is in front of the steering gear mounting minimizes the transmission of road vibration to the steering wheel.

159 - *What cross members does the frame have?*

(1) Two complete "X" members, with box section extending to the front end of the frame.

(2, 3, 4) Three straight members, including a new, heavy channel member across the "kick-up" at the rear wheels.

(5) The heavy sheet-steel body floor, bolted to the frame at 38 points. (See illustration on page 93.)

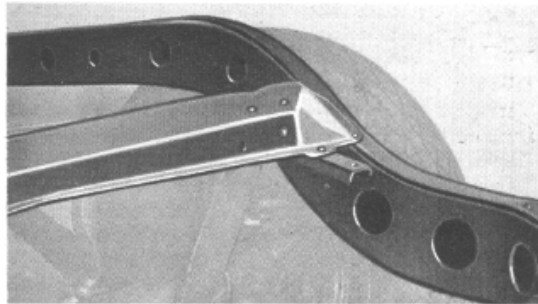

Frame side-rail at the rear "drop", showing heavy, boxed section and also the heavy channel cross-member.

(f) The heavy steel running board brackets, two on each side, which are bolted both to the side rail and the cross member. In addition to these, the motor supports at the transmission function, as a cross member and add to the strength and rigidity of the frame. In addition, the Hudson Six has a special cross member at the front to support the radiator.

160 - *Do any other cars have all of these?*

No. No other car has the complete broad backbone of sheet steel. Few other cars have 2 X-members, and few, if any, other frames have such complete box sections.

161 - *Are the Hudson and Terraplane frames as heavy as those of competitive cars?*

In depth of frame, in cross bracing, and in strength and rigidity, yes. In number of pounds of metal (dead weight), no.

RADIAL SAFETY CONTROL

162 - *What is Radial Safety Control?*

It is the exclusive front end design on Hudsons and Terraplanes, which greatly improves the riding, steering and braking qualities of the cars. It provides the Rhythmic Ride and permits Tru-Line steering. Two sturdy forged torque rods (one on each side of the chassis frame) are attached to the frame with rubber bushed pivot pins at a point in line with the steering Pitman arm, the rods being able to rotate vertically on the pivot pins, but having no side-wise movement. The front ends of the rods are fixed to the front axle at points just outside of the spring mountings; they serve to

carry the propulsion from the chassis to the front axle and wheels, and also to transmit the braking action of the front wheels to the chassis. Since the rods

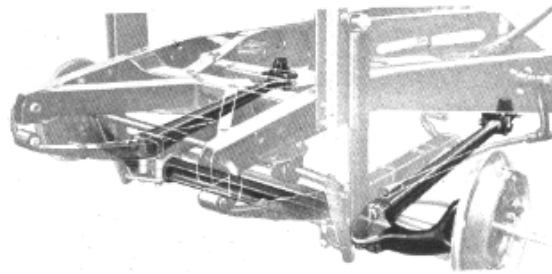

Radial Safety Control, phantom view, showing forged torque arms, which permit front axle to move only up and down in a true arc, and which provide safer riding, safer steering and safer braking. Note the frame's exceptionally rigid cross-bracing and Sturdy front-end construction.

are pivoted at the rear, they permit the axle to rise and fall freely as inequalities in the road are encountered, but the definite length of the rods permits the axle to move only in a true arc. The axle cannot move backward and forward with the spring-flex as it can do when the front springs are used as torque rods in the conventional front end design, and there is no sidewise movement. The springs are not rigidly mounted on the axle, but are on a lubricated saddle bearing, which permits the slight rotation of the axle in its up-and-down travel. This is done because the springs now have no function except to cushion the car.

(For further details on Radial Safety Control and its effect on riding, steering-and braking, see sections on Spring Suspension, Steering and Brakes.)

SPRING SUSPENSION

163 - *Is there any outstanding superiority in the spring suspension?*

Yes. Radial Safety Control, which is exclusive in Hudsons and Terraplanes, eliminates the braking torque "duty" of the front springs (see question No. 162), so that their only function is to cushion the car. It provides the Rhythmic Ride. Without Radial Safety Control, the front springs must act as a torque-arm, transmitting the propelling power from the chassis frame to the front axle and wheels, and also

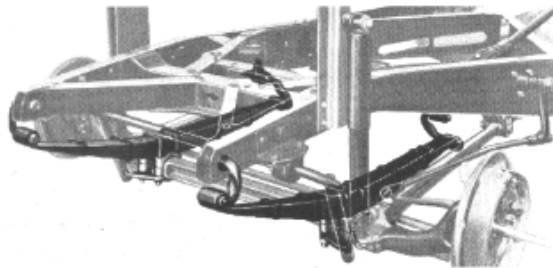

Rhythmic Ride - phantom view, showing front springs shackled at both ends and mounted on axle with saddle bearings to permit only rotating motion of the axle. Since the springs have no torque duty, either accelerating or decelerating, they do nothing but cushion the car. Note the frame's exceptionally rigid cross-bracing and sturdy front-end construction.

transmitting the braking power of the front wheels to the chassis. This requires a much heavier, stiffer spring than is needed for spring suspension only. The 1937 Hudson and Terraplane springs have a much softer, slower action, and consequently give a much smoother ride.

Since the front springs are not required to absorb brake torque, they are shackled at both ends.

164 - *How much softer are the 1937 front springs?*

As an example: 125 pounds of weight were required to deflect a 1936 Hudson spring one inch; 110 pounds will deflect a 1937 spring one inch.

165 - *What type of spring is used?*

The semi-elliptical type, as on costly cars. They are made of "Amola" steel.

166 - *Is independent front springing available?*

Yes, though not in the so-called "knee-action" sense. Radial Safety Control gives a smoother ride with the greater stability of the two torque rods, in addition to the sturdy front axle.

Hudson-built cars have independent springing in the sense that each front spring acts independently "of the other, and also independently of any brake torque action. Due to the softness of the springs, the deflection of one spring, caused by road bumps, has little effect on the other spring or the horizontal position of the chassis and body.

167 - *Do 1937 Hudsons and Terraplanes have stabilizer bars?*

Yes. A sturdy stabilizer bar toward the front of the frame assures a stability that contributes to the better riding and steering qualities.

168 - *Why is the stabilizer bar at the front of the frame, instead of at the rear as in 1936?*

Since the center of gravity has been lowered approximately 1½ inches, through the double-drop frame design, there is a new balance to the car that renders the rear stabilizer unnecessary (except possibly under the very worst road conditions).

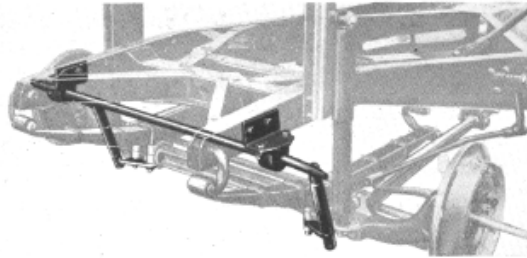

The new stabilizer bar shown in phantom at the frame front end. The stabilizer contributes greatly to the smooth ride and true, effortless steering in 1937 Hudsons and Terraplanes. The front end shock absorbers, springs and stabilizer are perfectly coordinated.

Note the frame's exceptionally rigid cross-bracing and sturdy front-end construction.

The new front stabilizer bar gives riding advantages that were not possible with the previous chassis design and car balance.

Exceptionally rough road conditions in a few sections of the country warrant an additional stabilizing factor so a rear stabilizer bar, similar to that used in 1936, is available for service installation.

169 - Why are leaf springs preferred to coil springs?

Because (a) they do not tend to soften, as do coil springs, but retain their original characteristics to a greater degree throughout their life; (b) they are safer;

the leaf spring is less likely to break because the winding of the coil spring in manufacture stretches the outer side of the spring wire and compresses the inner side, giving unequal characteristics to the different sections of the spring; further, if a leaf of the leaf-type spring breaks, the other leaves support the car, but if a coil spring breaks, all spring support is gone;

(c) the friction of the leaves gives a valuable "snubbing" effect that is not possible in coil springs.

170 - Have the springs been changed for 1937?

Yes. Both front and rear springs have been made longer, giving a softer, smoother ride.

171 - What are the spring dimensions?

	<i>Front Springs</i>	<i>Rear Springs</i>	<i>No. of Leaves</i>
Terraplanes	33" x 1 $\frac{3}{4}$ "	52 $\frac{1}{2}$ " x 1 $\frac{3}{4}$ "	10
Hudson 6 and 8	37 $\frac{1}{2}$ " x 1 $\frac{3}{4}$ "	52 $\frac{1}{2}$ " x 1 $\frac{3}{4}$ "	10

172 - Are the springs parallel with each other?

No. They are "splayed." This means that the rear ends of the springs are mounted farther apart than the front ends. This spreading of the springs prevents the swaying of the chassis and body at all speeds, and rolling when turning curves at high speeds. This exclusive Hudson design greatly increases the car's stability and the passengers feeling of security -

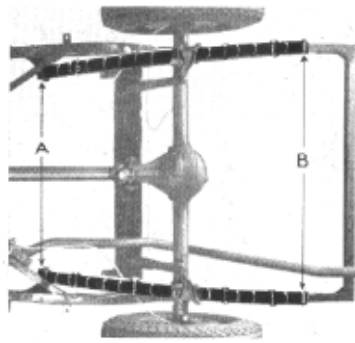

Splayed springs—note greater width at B than at A.

173 - Why is there a rubber pad between the spring and axle?

This permits a still softer, smoother spring action and further insulates the car and the passengers from road vibrations.

174 - Can Hudson-built cars "hit the axle" if a sudden severe jolt compresses the springs to the limit?

No. A rubber pad or "auxiliary spring" between the frame and the axle absorbs such jolts.

175 - What type of spring shackle is used?

The Unit-type shackle, a threaded and permanently self-adjusting, and free from rattles and squeaks.

176 - Are spring covers

Yes. Fabric spring covers are standard on all series except the Terraplane De Luxe. They retain the graphite lubricant and prevent foreign matter from entering between the leaves. Rust and grit between the leaves neutralizes the lubricant and reduces the friction surfaces.

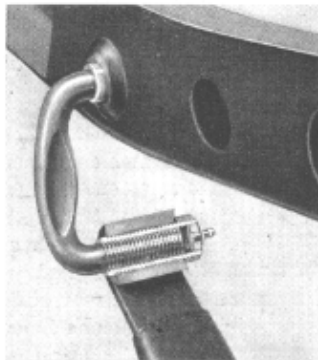

U-type, self-adjusting shackle, with lower threads exposed to show self-adjustment feature.

SHOCK ABSORBERS

177 - What type of shock absorber is used?

The Hudson Road Leveller direct-acting 2-way type. This type was first used by Hudson, but has now been adopted by other cars.

178 - Have they been changed for 1937?

They have been lengthened somewhat and the valving has been changed slightly to meet the requirements of the lowered frame and the longer, softer springs.

179 - Why are "Road Levellers" preferred?

They give the smoothest ride on both boulevard and rough road, are the simplest in design, require the least attention, and are the most nearly trouble free of all types. They have a much larger oil capacity than other types and the oil moves through larger apertures, thus providing a "soft" ride on smooth pavements, and tightening the action when rough roads are encountered. They have a direct 1 to 1 action, whereas other types have a 4 to 1 reduction. Consequently, the "Road Levellers" are four times as effective. The top and bottom parts of the cylinder are threaded, so that any one of five different valves may be inserted, to give any type of ride desired.

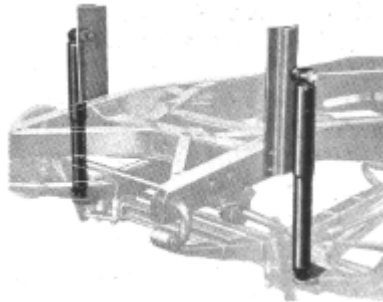
**180 - Do temperature changes affect "Road Levellers?"**

No. Because of the larger apertures, changes in the oil viscosity due to temperature changes have little effect on the action of the "Road Levellers". The valves in the 1937 shock absorbers have been revised to meet the requirements of the longer, softer springs.

181 - What are the relative oil capacities of the direct-action and the "elbow" type of shock absorbers?

The direct-action type holds from four to seven times as much fluid as the elbow type.

182 - *What are the pressures in the different types?*

Oil pressures in the direct-action type are from 400 to 650 pounds; in the elbow type, from 4,000 to 6,000 pounds.

183 - *Which type is more subject to leakage?*

The elbow type, principally because of its much greater oil pressures. Further, a small leakage in the elbow type is much more serious than an equal leakage in the direct-action type. For example, a quarter-ounce loss of fluid from the elbow type would represent probably 25% of the total capacity, but it would be only about 60/() of the capacity of the direct-action type.

184 - *Is there any proof of the greater sturdiness of the direct-action type?*

Yes; this type is used on airplanes, which must be equipped for extraordinary impact when landing. It is also used on the largest cannon to take up the terrific force of the recoil shock.

STEERING

185 - *What kind of steering do Hudsons and Terraplanes have?*

Tru-line Steering, which is accomplished through the Radial Safety Control design. With conventional spring control of the front axle, a slight rotary motion of the axle is unavoidable-for example, when the brakes are applied or released. This rotation changes the caster, or proper tilt, of the front axle. The caster is also changed as springs become older and their characteristics alter, or if there is a variation in the original characteristics of a set of springs. Changing caster affects steering. Too much caster causes shimmy;

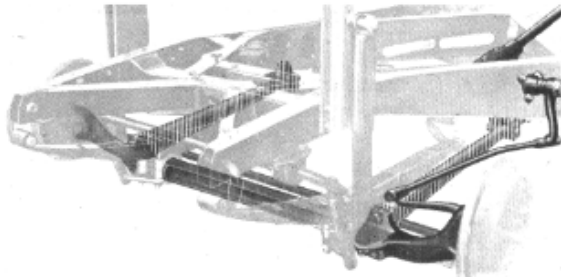

*Tru-line steering-phantom view-showing steering hook-up and, in "cross-hatching", forged torque arms that keep front axle in a true arc and retain Proper caster, providing Tru-Line Steering.
Note exceptionally strong cross-bracing and sturdy front-end con-*

too little reduces the "self-steer." The torque rods of the Radial Safety Control design prevent any change in caster, so there can be no variation in steering from that cause. The car actually tends to steer itself. It has "road sense."

186 - *What type of steering gear is used?*

The roller tooth type, which has less friction than other types, and consequently makes steering easier. It is a more expensive gear, than used in 1936 models.

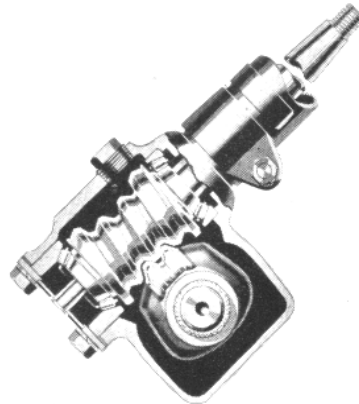

Cut-away view of new roller-tooth steering gear.

The worm shaft is carried on tapered roller bearings. It is a shock-cushion, "self-adjusting" gear.

187 - *What are the steering gear ratios?*

18.2 to 1 on all Hudsons and Terraplanes.

188 - *Is the steering column adjustable?*

Yes, in all series, it may be shim adjusted to give the most restful driving angle.

189 - *What size steering wheel is used?*

17 inch in De Luxe Terraplane models. 18 inch in all other models.

190 - *What type of steering wheel is used?*

In all Hudson models and Super Terraplane models, the wheel has a modern, plastic-covered, steel-cored rim, with spokes comprised of rods of stainless steel. At the hub, the spokes are set in another steel rim, for greater strength and safety. In De Luxe Terraplane models, the wheel is of the highly polished hard rubber type with steel core. The rubber rim is molded to fit the hand, so that the thumb and all fingers rest easily on it.

191 - *What is the advantage of the type of wheel with the stainless steel spokes?*

The slight flexibility of the spokes makes driving somewhat more restful. The flexibility is not sufficient, however, to affect the steering action in the least.

192 - *What is the turning radius?*

Terraplane - 20 feet, 3 inches. Hudson Six and Hudson Eight (122" w.b.) - 21 feet, 3 inches. Hudson Eight (129' w.b.) - 22 feet, 6 inches.

BRAKES

6

193 - *What kind of brakes do Hudsons and Terraplanes have?*

Duo-Automatic Hydraulic brakes.

194 - *What does "duo-automatic" mean?*

It means that it is a double system, or two systems so hooked up that one supplements the other. If the primary system should fail to function properly, the secondary system then does the braking.

195 - *What is the primary system?*

A conventional hydraulic system, with internal expanding, low-velocity, servo-acting brakes operating on all four wheels.

196 - *What is the secondary system?*

Hudson Rotary Equalized mechanical brakes, operating on the rear wheels.

197 - *How does the one system supplement the other?*

When the brake pedal is applied, the hydraulic brakes "take hold" at a certain point in the pedal travel, as is customary. If for any reason the hydraulic brakes should fail to "take hold" at the proper point, a slight additional travel of the pedal (about one inch) applies the rotary-equalized mechanical brakes. This application of the mechanical brakes is absolutely automatic and requires no action by the driver except pressure on the brake pedal.

198 - *Why did Hudson adopt Duo-Automatic Hydraulic brakes?*

Hydraulic brakes were adopted because they are inherently equalized and consequently prevent side

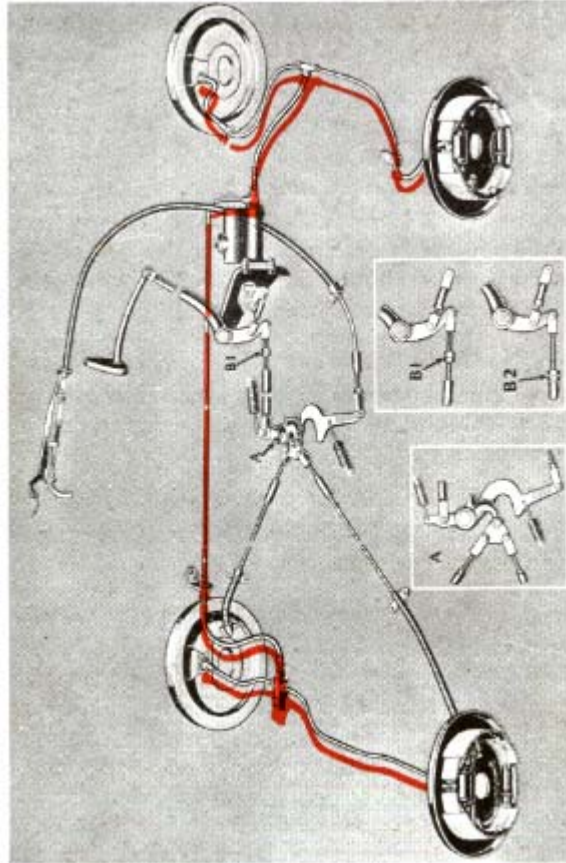

Duo-Automatic Hydraulic Brakes showing Primary Hydraulic System (Hydraulic lines in red) and Reserve Mechanical System. A - Hudson Rotary Equalizer on Reserve Mechanical System. B - Normal position of "pick-up" design; Hydraulic Brakes take effect at this point when pressure is applied to the pedal, B 2 - Position at which Reserve Mechanical Brakes are applied; note that the "pick-up" nut has traveled approximately one inch to contact the sleeve that actuates the Rotary Equalizer and the Mechanical Brake,

skidding and other dangers that are possible with unequalized brakes; also, they provide the smoothest stopping and require a minimum of effort by the driver. The possibility of loss of braking effectiveness (through loss of fluid or

other cause) makes a supplementary system necessary for absolute safety of the passengers at all times. Hudson Rotary Equalized mechanical brakes were adopted as the supplementary system because they had proved their efficiency and their positive operation at all times. Although they operate on the rear wheels, instead of all four wheels, they are ample to control the car in an emergency, and may be used with



Rear wheel brake assembly, showing mechanism for application of both hydraulic and mechanical pressure in Hudson's Duo-Automatic Brakes.

complete safety until the hydraulic brakes are again functioning.

199 - *Do the hydraulic and mechanical systems operate different shoes at the wheels?*

No; they actuate the same shoes, thus assuring the most effective braking performance.

200 - *What does "servo-acting" mean?*

It means that the power of the revolving Wheels is utilized to set the brakes and stop the car. The revolving brake drum actually pushes the brake shoe harder against itself (the drum). This power is controlled by the brake pedal. The car

motion contributes to the powerful yet easy brake action.

201 - *Is there any difference between the "genuine 100% hydraulic brakes" advertised by some manufacturers, and the hydraulic brakes used in Hudsons and Terraplanes?*

Yes. Hudsons and Terraplanes use "100% hydraulics PLUS." All hydraulic systems are exactly the same except for the method of operating the brake shoes - Hudsons and Terraplanes having the Bendix method of operation, and some other cars having the Lockheed method.

In the Lockheed, or so-called 100% type, each brake shoe is anchored individually at the bottom (A), and the top ends of the two shoes are pushed outward against the drum by

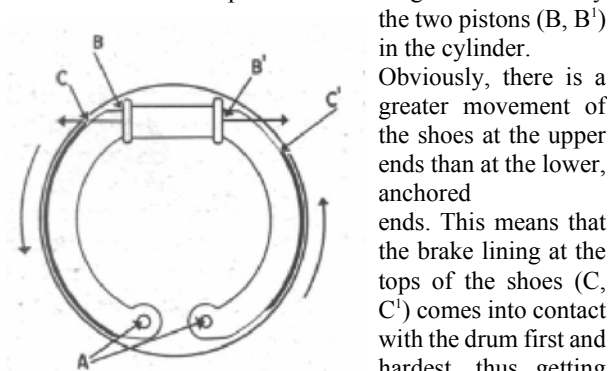

Lockheed type of brake shoe application. Curved arrows indicate rotation direction of brake drum.

the two pistons (B, B') in the cylinder.

Obviously, there is a greater movement of the shoes at the upper ends than at the lower, anchored ends.

This means that the brake lining at the tops of the shoes (C, C') comes into contact with the drum first and hardest, thus getting the greatest wear-in fact, it will wear out completely at the top, requiring replacement,

while there is still considerable unused lining at the bottom end of the shoe. It also means that only the upper part of the brake shoe is doing full work, and consequently the brakes are not 100% efficient.

There is some servo-action to assist the hydraulic pressure

pressure on the first shoe (left-hand side shoe in the illustration), but there is no servo-action whatever in the second shoe. On the contrary, the pressure of the revolving drum creates an anti-servo-action, which pushes against the hydraulic pressure and partially nullifies it. So this type of brake application is less than 100% efficient. Further, since there is less braking pressure on the second shoe, its lining must be made shorter so that it will wear out uniformly with the lining on the first shoe, so again this brake is not 100% efficient. (Note shorter lining in second shoe.)

In the Hudson-Bendix type, the shoes are not anchored at the bottom, but there is a linkage (D) that transmits the servo-action of the primary shoe to the secondary shoe. The only anchorage is a floating, spring-tension anchorage' (E) at the top of the secondary shoe.

Equal pressure is exerted by both pistons (F, F') and the brake lining covers the full length of each shoe. There is full servo-action in the primary shoe, adding to the 100% hydraulic pressure, and there is also full servo-action in the secondary shoe, adding still further to the hydraulic pressure so they are 100% hydraulic PLUS. The full length of both brake shoes comes into instant and complete contact with the drum.

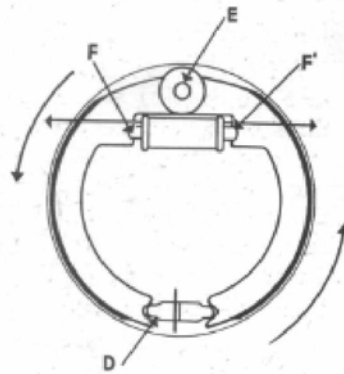

Hudson-Bendix type of brake shoe application. Curved arrows indicate rotation direction of brake drum.

This maximum friction surface causes quicker, safer stopping, and also causes even wearing of the brake lining. Thus the lining will last longer-an important economy item.

202 - What is the "rotary equalizer?"

It is a steel unit to which the secondary brake cables are attached. The rotary action of the equalizer, when the brake pedal is applied, actuates the cables in an absolutely equal movement at equal pressure, stopping the car quickly and smoothly in a straight line. It is simpler than other equalizing designs and does not require adjustment. It is an exclusive Hudson and Terraplane design. (See illustration on page 110.)

203 - How does Radial Safety Control affect the braking action?

Since the braking action of the front wheels is transmitted to the chassis through the forged torque rods (see question No. 162), the deceleration is more prompt and positive than when the springs are used for the braking torque. With Radial Safety Control, there is no "nose dive" by the front end of the car when the brakes are applied, as in other cars.

204 - What type of brake drums is used?

The drums are of alloy steel, machined and polished and are of a special thickness to assure concentricity under all operating conditions.

The brake drums are held to .003" to .005" eccentricity, with the drum rotating on the wheel spindle.

205 - What are the brake shoe dimensions?

	Shoe Lengths	Width
Terraplane	2 2 ¹ / ₈ "	1 3 ⁴ / ₄ "
Hudson Six	2 2 ¹ / ₈ "	1 3 ⁴ / ₄ "
Hudson Eight	2 3 15 ¹⁵ / ₁₆ "	1 3 ⁴ / ₄ "

206 - How is rusting of brake parts prevented?

Actuating parts are heavily plated. Brakes are also protected by centrifugal shields against splash.

207 - How is the braking power divided between the front and rear wheels?

50-50.

208 - Can water or mud be thrown into the brakes?

No. A baffle plate prevents water and abrasives from being thrown into both the front and rear brakes.

209 - How is the parking brake applied?

On the rear wheels. The operation is through the rotary equalizer and is the same as that described under questions Nos. 197 and 202, except for the manner of application.

210 - How is the parking brake operated?

By hand-control conveniently placed under the cowl. This has a finger-release for extra ease of operation and, when the Electric Hand pre-selective shift is used, leaves the front compartment clear, with added leg room.

211 - What is the Hydraulic Hill-Hold?

It is an installation, optional at extra cost in all Terraplanes and Hudsons, that will keep the brakes applied and prevent the car from rolling backward when stopped on an up-grade. The Hill-Hold unit is a small -cylinder that is attached to the hydraulic brake master cylinder and that has a valve which is actuated by depressing and releasing the clutch pedal. Fluid from the hydraulic master cylinder passes through the Hill-Hold cylinder enroute to the wheel brakes when the brake pedal is depressed, and returns through the same -course when the brake pedal is released.

However, if both the clutch pedal and brake pedal are depressed, the Hill-Hold valve (actuated by the clutch pedal) holds the brake fluid in the lines and keeps the brakes applied, although the brake pedal may be released. The brakes will remain applied as long as the clutch pedal is kept depressed.

212 - *If the clutch pedal must be kept depressed, what is the advantage of the Hill-Hold?*

There are two advantages. First-clutch pedal pressure is much lighter and less tiring than brake pedal pressure. Second-by using the left foot on the clutch pedal, the right foot is free, to use on the accelerator, so that the car may start smoothly up the hill. When the right foot has to be shifted quickly from the brake pedal to the accelerator on a hill side, there is a possibility of killing the engine.

THE AXLES

(Note-Also see "Radial Safety Control"-question No. 162.)

213 - *What kind of front axle is standard?*

The Elliott type, with the axle forks forged integral with the sturdy axle beam. It is a solid forging of high grade steel. A heavy ball-bearing tie-rod is used.

214 - *What is unusual about the Hudson-built front axle and steering knuckle assembly?*

The ball bearing that supports the weight of the car is to assist in easy steering, in a housing between the king pin and the axle forks, instead of being exposed, and the king pins are made of nickel-molybdenum alloy. In 1937 models, the king pins have been made larger, increasing their strength, and they are continuously lubricated, improving the steering.

215 - Why is nickel-molybdenum alloy steel used for king pins and other vital parts?

Where a great strain or over-load might cause the usual material to break, nickel molybdenum will only bend. It is the safest material for severe service.

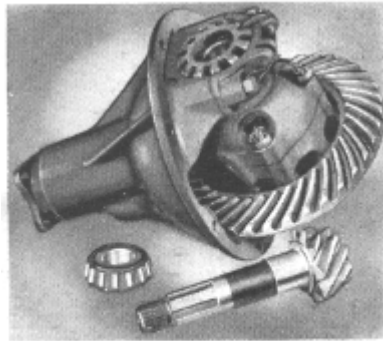

Sturdy rear axle gear construction—ring gear and pinion are nickel-molybdenum alloy steel.

216 - What kind of rear axle is used?

A semi-floating, fully adjustable rear axle.

217 - What are the advantages of the Hudson-built rear axle?

1. Minimum unsprung weight, with great strength.
2. Tapered roller bearings throughout.
3. It is fully adjustable, including wheel bearings.
4. Ring gears and drive pinion are of nickel-molybdenum alloy steel.

218 - What type of driving gear is used?

The spiral bevel type.

219 - What is the axle ratio?

4-1/9 to 1 on all models

220 - What type of universal joint is used?

Needle roller bearing joints, with sealed lubrication, which give better distribution of the power load. Friction is minimized and the life of the universal is indefinitely prolonged. The needle roller bearings afford more capacity than the heaviest service could possibly

require. All Hudson-built cars have two universal joints, whereas some cars use only one.

221 - *Has the propeller shaft been changed in 1937?*

Yes. The tubular shaft has been made larger and correspondingly stronger.

222 - *What type of drive is used?*

Hotchkiss drive. With this type, the torque, or propelling force of the rear axle is transmitted through the rear springs to the chassis. Similarly, the decelerating torque of the brakes is transmitted to the chassis through the rear springs, as well as through the torque arms from the front axle to the frame.

223 - *What are the -advantages of the Hotchkiss drive?*

The car rides easier and holds the road better, because of the flexibility of the rolling parts, and the lower unsprung weight, as compared with other types of drives. The springs tend to "cushion" the quick forward thrust of a sudden acceleration, and likewise "cushion" a quick deceleration. This not only adds to passenger comfort, but protects the car mechanism. Less tire noise is transmitted to the body.

WHEELS AND TIRES

224 - *What size and type of wheels are used?*

16" steel wheels are standard. 15" steel wheels are optional at extra cost.

225 - *What sizes of tires are used?*

Standard sizes: 16 x 6.00 on Terraplane and Hudson Six; 16 x 6.2 5 on Hudson Eight.

Optional at extra cost on all Terraplanes and Hudsons:
15 x 7.00.

226 - *What tire pressures are recommended?*

In all models: front, 24 pounds; rear, 32 pounds.

MISCELLANEOUS

6

227 - What type of chassis lubrication is used?
Pressure lubrication with self-cleaning chassis fittings.



Some of the 30 anti-friction, heavy duty roller and ball bearings in one Hudson-built car.

228 - Are many roller and ball bearings used in Hudson built cars? P

Yes, 30. Probably more and larger bearings than in any other cars in their price fields. D

229 - What type of bumper is used?

Wide-range" bumpers., The full width and extreme up-and-down" range give the car maximum protection Front and rear bumper-guards are standard equipment. D
 S

230 - What type of running board is used?

Heavy sheet steel, with a round flanged edge to add strength, and with a durable, heavy-ribbed rubber mat. D

231 - How are the running boards mounted?

On heavy steel channel brackets riveted to the side rails and the X-member, thus forming additional cross-members and adding further strength to the chassis. P

232 - *Do the running boards provide any protection?*

- D** Yes. Because of their own strength and that of the bracket, they are actually side-bumpers that protect the body from side collision.

233 - *What type of muffler is used?*

- D** The baffled type which is big enough to accommodate the exhaust from an even larger engine, and still provide maximum silence. Muffler and tail pipe brackets are attached to the frame by rubber-mounted brackets, further eliminating noise and vibration.

234 - *Is the body insulated against heat from the muffler?*

- D** Yes. A new feature in 1937 is the metal plate fastened horizontally to the frame and located between the muffler and the body floor. The stream of air passing on both sides of the plate carries away the heat and prevents its reaching the body.

235 - *What is the capacity of the gasoline tank?*

16½ gallons in all models. As a precaution against letting the gasoline tank run dry, the fuel gauge in the instrument panel is set to read "empty" when 2½ gallons still remain in the tank.

236 - *Is the gasoline tank filler easily accessible?*

- D** Yes. The tank is placed somewhat forward from the conventional position, and is protected from stones thrown by the wheels. Further, it is protected by heavy rear cross members against collision from the rear.

237 - *What is the road clearance?*

Front axle center, 8⁹/₁₆"; rear axle center, 8⁷/₁₆".

238 - *In what manner are the body and chassis joined?*

- D** They are virtually one unit. The sheet steel cross member, which is bolted to the chassis frame at 38 points, is also the body floor and is welded inseparably to the box girder type all-steel body shell.

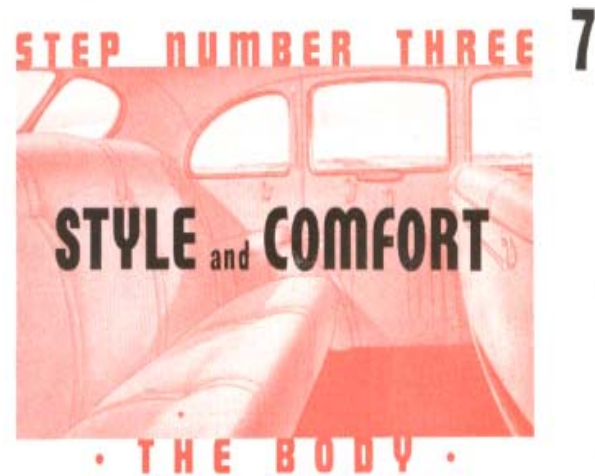

FOR 1937, Hudsons and Terraplanes are completely new, These new bodies all of steel are structurally planned for durability and safety. Artistically, they are designed for useful style-style that has lower, wider, more graceful lines with more roomy and luxurious interiors.

A look at the 1937 body styling is an inspiration to a selling man. Viewed from the front, the distinctive radiator with stainless steel grille, blends in artistic harmony with full crowned fenders. Bumpers are rounded for beauty as well as service. Louvres make part of a picture in addition to ventilating the power plant. Headlamps are decorations by day and safety beacons by night. The broad "V" windshield has tasteful lines symbolic of the trend-leading style.

Every part is engineered for safety and ruggedness as well as beauty.

From the side, these lines of ruggedness form a profile of beauty. Long, graceful hood, with its slim chromium trimmed louvres, indicates the speed of the quiet, powerful motor. The sweeping lines of the one-piece solid steel roof show the scientific stream-lining proved in wind-tunnel tests. Fenders over the new steel wheels, their full crowns sweeping to the satisfaction of the most particular stylists, harmonize with a round-edged running board that is so sturdy that it becomes a side bumper.

Open a spacious door with its safety styled handle . . . doors open to their full width . . . front doors more than a yard wide . . . rear doors in excess of 18 inches at the floor. Enter the luxurious interior which has ample room for six . . . seat room . . . head room . . . leg room, on spacious level floors.

Hudson and Terraplane bodies are built in the Hudson Motor Car Company's own gigantic body plant. They are designed by the same engineers who design the chassis and they join the frame so that the body and the chassis become a single unit.

Hudson has been building steel bodies since 1926, and was the first to build a body of solid steel ... first to have a seamless solid steel roof. The industry now is following Hudson's lead.

There is not a single piece of wood in any structural part of a Hudson or Terraplane body. Steel roof, steel floor, steel front, steel rear ... all are built over a frame of solid steel. All parts are welded together to make a one-piece body free from rattles and squeaks. Here is a stronger body . . . and a lighter body with no useless weight to push up gasoline costs.

The instrument panel, of ultra modern design in rich, walnut finish, also is solid steel. The cowl is solid steel and both these are welded in place as structural cross-members.

The body is insulated against weather and sound. The domed ceiling has the same insulation found in the better electric refrigerators. Under the carpeted rear floors and the heavy rubber covered front floor are layers of jute, as protection from outside heat and cold. All doors are rubber scaled against drafts that rob a ride of comfort.

Individual, year around, draft-free ventilation is attained, either by sliding windows or wind deflectors. The cowl ventilator, equipped with insect screen, is a full 17 inches wide and three inches deep.

Exclusive qualities of Hudson and Terraplane bodies - steps ahead in safety, style and room-are sales clinchers. On the following pages every detail is explained in full.

**HUDSON-BUILT CARS for 1937
are THREE BIG STEPS AHEAD in**

- P** - PERFORMANCE, including Economy
- D** - DRIVING and RIDING, including Safety
- S** - STYLE and COMFORT

Every part in Hudson-built cars contributes to one or more of these superior qualities. In reading the following pages, note the symbols in the margin beside the answers. They point out why Hudson built cars are ahead in each of the three big and important values.

**BODY
QUESTIONS AND ANSWERS**

239 - How many Terraplane and Hudson passenger car body models are there?

Forty-four, as follows:

Terraplane De Luxe models:

Brougham	Sedan
Touring Brougham	Touring Sedan
Victoria Coupe	3-Passenger Coupe
Convertible Coupe	Convertible Brougham

Super Terraplane models:

Brougham	Sedan
Touring Brougham	Touring Sedan
Victoria Coupe	3-Passenger Coupe
Convertible Coupe	Convertible Brougham

Hudson Custom Six models:

Brougham	Sedan
Touring Brougham	Touring Sedan
Victoria Coupe	3-Passenger Coupe
Convertible Coupe	Convertible Brougham

Hudson De Luxe Eight (122-inch wheelbase) models:

Brougham	Sedan
Touring Brougham	Touring Sedan
Victoria Coupe	3-Passenger Coupe
Convertible Coupe	Convertible Brougham

Hudson Custom Eight (122-inch wheelbase) models:

Brougham	Sedan
Touring Brougham	Touring Sedan
Victoria Coupe	3-Passenger Coupe
Convertible Coupe	Convertible Brougham

Hudson De Luxe Eight (129-inch wheelbase) models:

Sedan	Touring Sedan
-------	---------------

Hudson Custom Eight (129-inch wheelbase) models:

Sedan	Touring Sedan
-------	---------------

240 - *In what ways do Terraplane De Luxe models differ from the Super Terraplane models?*

Super Terraplanes have the following additional values:

5 additional horsepower	Short pile carpet
Automatic carburetor	Double down-draft carburetor
heat control	
Automatic choke	Spring spoke, Tenite rim
Voltage regulator on generator	steering wheel
	Spring covers
Twin air horns	Assist cords
Ventilating wings	Front fender ornaments
Parcel compartment lock	Front fender ornaments'
Front compartment	Trunk, or luggage compartment door-
Floodlight	ornament
Etched aluminum scuff plates	

Twin tail lamps	Colored rubber front
Swivel type sun visor	compartment mat
Instrument panel	Custom boucle or custom
ornamental moulding	mohair upholstery

241 - *In what ways do the Hudson Custom Eight models differ from the Hudson De Luxe Eight models?*

Custom models have:

Built-in radio	Door pull-to cord on
Fenders lacquered in	front door
body color	Ash tray in rear arm rest
Cigar lighter in	(De Luxe 129" w.b.
instrument panel	Sedan is only De Luxe
	model with ash tray in
Cigar lighter in rear arm	rear arm rest)
rest (De Luxe 129"	Electric clock
w.b. Sedan is only De	Twin swivel sun visors
Luxe model with cigar	Valance Tenite plaque
lighter in rear arm	Long pile carpet
rest)	Chrome moulding
Folding table top in front	inside door trim
seat back (in Custom	Custom loom cloth
129" w.b. Sedan only)	upholstery

242 - *Are Hudson and Terraplane bodies roomy?*

Yes. Sedans and broughams have 150 cubic feet capacity (129" w. b. sedan bodies, which are 7 inches longer, have 162 cubic feet capacity), which is more than any other cars in their price class. There is ample room for three passengers in both front and rear seats. Leg-room is greater than in nearly all other cars, and headroom is ample in all models. (See illustration on page 127 for all interior measurements.)

S

7

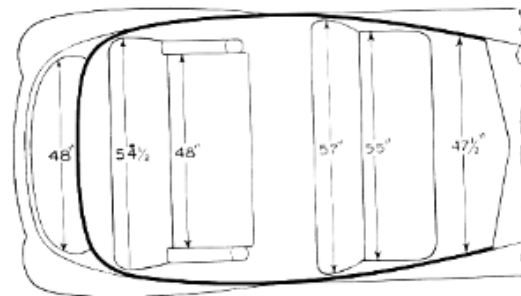
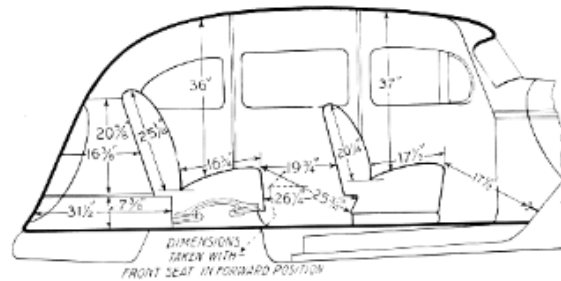

This diagrammatic drawing shows the exceptional seat room, leg room, head room and luggage space in Hudsons and Terraplanes.

243 - Have the brougham front seats been changed?

Yes. The seats are solid, the same as sedan seats. This gives comfortable room for three people. The seat back is divided as before, with both halves hinged to fold forward. S

244 - Are the drivers' seats adjustable?

Yes. All front seats can be adjusted to accommodate the tallest or shortest driver. A lever at the side of the seat releases the locking mechanism and permits the seat to slide easily, through a 4-inch range, to the desired position. Releasing the lever locks the seat in the new position.

S



Lock-lever for driver's seat adjustment.

In 1937, the tracks at both sides of the seat are geared together (only one side geared in 1936) to permit easier movement and prevent sticking. The seat cushion and backs are slanted to give the most

relaxed posture.

245 - Are rear seats adjustable?

S Yes. Sedan and brougham rear seats may be moved 1½ inches forward, to fit on dowel pins. This is not a mechanical adjustment. The seats must be lifted to the new position.

246 - Is there any other new seat adjustment feature?

S Yes. In 1937, all brougham, Victoria coupe and convertible brougham front seats are pivoted at the left hand side, so that the right-hand side may be swung forward, permitting easier access to the rear compartment through the right-hand door. Pushing forward on the seat back actuates this forward movement of the entire seat. This is a great convenience feature.

247 - *What type of seat is used on 3-passenger coupes?*

The adjustable, full-width seat, giving ample room for three persons and providing the same type of seating arrangement as is found in the sedan front compartment. The commodious space just behind this seat is available for luggage. The folding seat back makes the space easily accessible.

S

248 - *What is the Victoria coupe seating arrangement?*

The pivoted full front seat, for 3 passengers is described under question No. 246. The seat for the fourth passenger is placed transversely behind the front seat, occupying the same space that, in the 3-passenger coupe, is available for luggage. The pivoted seat, with the folding back, gives easy access to the transverse seat.

249 - *What type of body is used by Hudson?*

Unit steel; sides, floor, ends and roof are of steel, giving the highest degree of safety built into any automobile today.

D

250 - *Is no wood used at all?*

Not for structural purposes. Wood top bows are used, but only as a base for attaching the headlining. The bodies do not even have wood floor sills.

D

251 - *Are they like the steel bodies on other cars?*

No. Under the Unit-Engineering plan the body is a complete steel entity. The steel floor panel is welded to the body so that it helps to form a complete steel box, each side of which reinforces each other side. Structurally, the design is comparable to the steel structure of a bridge, or an ocean liner - in which each structural part strengthens those adjoining.

D

252 - What type of top is used?

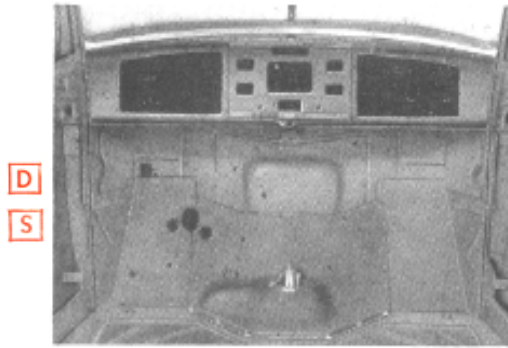

One of the rugged steel box sections of a Hudson-built body.

A steel top, which is a smooth, solid unit with the body shell. There are no seams or joints in the roof and body structure; just a complete steel box.

253 - *Will the steel roof be noisy or cause drumming?*

S No. Hudson engineers have worked at this problem from two sides to achieve a silent body—they have eliminated vibration, the cause of body drumming, and have also developed sound-deadening construction to its highest point.

254 - *How is vibration eliminated?*

In many ways, two major ones of which are: 1. The development, several years ago, of the Hudson compensated crankshaft, the smoothest running crankshaft known today. 2. The use of a type of rubber cushion engine mountings that damp out any minute engine vibrations that would otherwise be transmitted (through rigid mountings) to the body and would tend to set up "sympathetic" body vibrations. The steel roof, being the largest unbroken section of sheet metal, would be most affected by such vibrations.

255 - *How has Hudson sound-deadened the steel roof?*

Sheets of insulating board are cemented to the under side of the roof. Next underneath these are loosely placed strips of

7

Masonite, a hard material usually used as building board. The Masonite strips are held up by the top bows, but there is a heavy layer of wadding between the bows and the Masonite. The Masonite is not screwed or rigidly fixed to the bows, but is only supported by them. There is a direct contact between the steel top, the insulating board, the Masonite, the wadding and the top bows, but since each of these materials has a different vibration frequency (or vibration wave length), they damp out and completely eliminate any vibration that might be started in the steel roof.

S

D

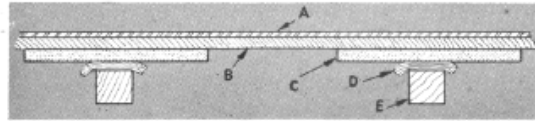

Sound-deadening construction of Hudson-built body roofs: A - Heavy gauge sheet steel. B - Insulating board cemented to steel, C - Masonite strips, running across the top and held against the insulating board, but not firmly fastened either to the insulating board or the supporting top bows. D - "Blue wadding," insulating top bow from Masonite. E - Top bow.

256 - *Is this insulation also effective against heat and cold?*

Yes. In fact, the materials and method of construction are the same as in mechanical refrigerators.

S

257 - *What are the advantages of Hudson steel bodies over composite bodies (steel and wood)?*

The same that a steel railroad coach has over a composite coach. They are much safer, quieter and longer lived.

S

258 - *Are the body doors also of steel?*

D Yes. In fact, they are double strength, the inner as well as the outer wall being of steel, with overlapping flanges. They are so strong and rigid that, with a heavy man's weight hanging from them, they will still swing freely and close perfectly.

259 - *Will the doors squeak or rattle?*

No. A small oil reservoir in each door hinge prevents hinge squeaks. Also, the dove-tail and striker plates are lubricated with saturated wicks (patented by Hudson). Dove-tails and striker plates are also adjustable to prevent door rattle. This feature is exclusive to Terraplane in its price class. The lubrication feature is exclusive to both Terraplane and Hudson.



Wide door and clear front compartment

260 - *How are Hudson and Terraplane front doors hinged?*

At the front side.

261 - *Are there any other structural features adding strength to the body?*

Yes. The instrument, a heavy steel stamping, is an integral structural part of

the front end, combining with the cowls, and the dash-to-pillar braces to form a complete box section. The windshield pillars, the top header (the front portion of the roof immediately over the windshield) and the cowl are formed from one welded solid piece, making another box section.

262 - *Are the bodies insulated in any way?*

Yes. The body is completely insulated and the passengers are thoroughly protected from heat and cold, motor fumes and resonance. A heavy jute pad, under the rubber floor mat, extends from under the front seat forward to the dash and up to the cowl. The car wiring coming through the dash is strung through this padding and then up the dash. Over this dash padding and the wiring is laid another heavy layer of jute padding, which serves two purposes: 1 - It covers the holes in the under-layer through which the wiring comes, and thus prevents engine fumes from entering the car; the wires are sandwiched between the two layers. 2 - It provides additional insulation at the place where the engine heat would be greatest. An embossed, laminated finish panel covers the dash insulation. The jute padding under the floor mat is cemented to the floor, both as an insulation and as a carpet pad. A sheet of insulating board covers the rear deck floor of coupes and convertibles. Ventilating wings and all windows are rubber sealed in place in the fully closed position. The doors are weather-stripped. They also have a tubular rubber seal strip around the door opening that completely seals the crack when the door is closed. The roof insulation is described under question No. 254.

All welded seams in the steel body are sealed with rubber sealing compound.

263 - *What else contributes to the unusual quietness?*

- S** The permanent rigidity of the body, the perfect fit of the doors and windows, the accuracy and adjustable features of the door lock and other hardware and the padded door trim panels.

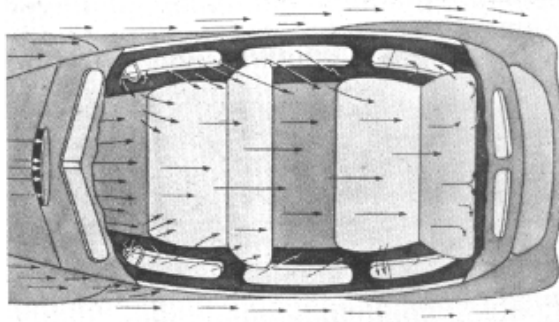

264 - *Do Hudsons and Terraplanes have draftless individual ventilation?*

- S** Yes. The Hudson complete year-round ventilation is an important health asset, as absence of drafts minimizes danger of colds, bronchial and sinus infections and similar ailments. It is also a tremendous comfort asset while riding. Each passenger may control the ventilation for himself - have as much fresh air as he wants-without affecting any other passenger. Utilizing the natural air currents, the Hudson system prevents drafts, clears the car of smoke and stale

vents drafts, clears the car of smoke and stale air, circulates the air in the car, cools the car in hot weather, and prevents clouding of the windshield and windows.

265 - *What is the Automatic Draft Eliminator?*

A very important and exclusive advancement for the admission of fresh, filtered air to the car in winter driving. In cold-weather driving, it is frequently desirable to have one ventilator slightly open for fresh air. The suction of the passing air outside of the car sucks the stale air from the car and this must, of course, be replaced by air from some source. Normally, it would leak in around the doors and windows, causing drafts about the passengers' feet, but Hudson and Terraplane bodies are so tightly sealed as to prevent this. New air is admitted through a hole in the floor immediately over the rear axle, the suction power of the vacuum created in the body being sufficient to draw the fresh air in if the car is traveling at 8 miles per hour or faster. The air is filtered by a bag made from a fabric similar to that in a vacuum-cleaner bag.

266 - *Will the air coming through the filtering bag cause drafts, especially on the feet of rear-seat passengers?*

Absolutely not, because drafts could not pass through the fabric bag or the seat fabric. Instead, the air will be diffused draftlessly into the car in many ways through the side-walls and around the window frames, up to the roof of the car and through the headlining, etc. The air will "seep", but never cause drafts.

267 - *Will the filtering bag get clogged with dust?*

Possibly, but it can be easily removed, and can be cleaned by shaking.

268 - Are there any other special ventilating features?

Yes. The most advanced in the industry. In addition to year-round draftless individual ventilation, all 1937 models (except the Terraplane De Luxe series) have divided front windows, the front portion of which may be

S

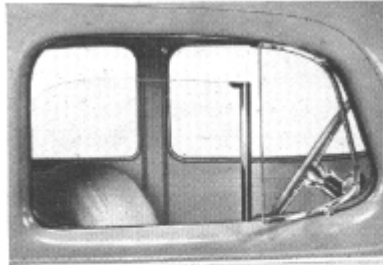

Ventilating wing that serves as wind-deflector, or wind scoop, or may (on all Hudson Eight models) be lowered into door.

used as a deflector, or as a wind scoop, or may - in Hudson Eight models - be lowered fully into the door, so that, with the rear portion of the glass down, the front seat passenger may have a fully opened window. The complete movement of the front portion - as a deflector, wind scoop, or down - is made with one handle. In the Terraplane De Luxe there is a solid window with full ventilating operation. A continuous motion of the handle moves the glass back and then down to open; reversing the process to close.

269 - Is there a cowl ventilator?

S



17-inch cowl ventilator, with insect screen.

Yes. An unusually large ventilator (17" x 3" opening). An insect screen is standard on the ventilator.

270 - *What Provision is made to keep the windshield clear of vapor and ice?*

All 1937 Hudsons and Terraplanes have two openings in the instrument panel, one each at the bases of the two panes of the deep V-windshield. Both the Hudson Custom and the De Luxe types of heaters have a separate outlet to which may be attached a special defroster connection to carry heated air to the openings. The flow of the warm, dry air from the base of the windshield effectively clears away any vapor from the inside, and prevents ice and frost from glazing the outside surface.

D

271 - *Is there a "tunnel" in the floors of Hudsons and Terraplanes?*

No. The floor of the rear compartment is level for the comfortable accommodation of passengers' feet and legs. Despite Hudson-built cars being nearly two inches lower this year, it has not been necessary to leave a pronounced hump in the floor to give clearance for the drive shaft, as is the case in many other cars.

S

272 - *What is the Baggage Compartment?*

The compartment in the rear of the Sedan and Brougham bodies that holds the spare tire and luggage. The tire is laid flat in the bottom of the compartment, with a wooden floor over it to hold the luggage. The tire, held in place with a single nut, is easily and quickly removed. The tire clamp is placed toward the side in the 1937 models, permitting the floor to be lowered and giving greater luggage space. The tire may also be side-mounted in the fender, adding greatly to the already capacious luggage space. The door to this compartment is dust-proof and water-tight and has a thief-proof lock.

S

273 - *Do other body models also have haggage compartments?*

- S** Yes. In the coupes and convertible models, the rear deck is a spacious baggage compartment. The elimination of rumble seats leaves this space clear.

274 - *Are trunk models available?*

Yes. The Touring Sedans and Touring Broughams are trunk models. The tire may be side-mounted to increase the luggage space.

275 - *How much luggage space is there?*

Sedans and Broughams:

- Compartment with tire mounted inside - 9½ cu. ft.
- Compartment with tire side-mounted - 16½ cu. ft.
- Trunk model with tire mounted inside - 12 cu. ft.
- Trunk model with tire side-mounted - 19 cu. ft.

Coupes:

- Business Coupe with tire mounted inside - 20½ cu. ft.
- Business Coupes with tire side-mounted - 27½ cu. ft.
- Victoria Coupe with tire mounted inside - 16½ cu. ft.
- Victoria Coupe with tire side-mounted - 23½ cu. ft.
- Convertible Coupe with tire mounted inside - 15½ cu.ft.
- Convertible Coupe with tire side-mounted - 22½ cu. ft.

276 - *When the tire is side-mounted, what kind of tire cover is used?*

- S** An easily removable, close-fitting metal cover that harmonizes with the body design.

277 - *What type of upholstery is used?*

- S** The piped type, that is used in the most expensive cars. (Current upholstery fabric options are shown in the "Price and Equipment List".)

278 - *What kind of seat cushions is used?*

What is known in the industry as the full luxury type. 1937 seat cushions are completely redesigned. All coils are directly supported by either the four steel supports in the cushion frame or the four wood supports in the seat frame. The 1936 cushions had four unsupported rows of coils, because of fewer available supports. The cushion frame is of much heavier wire and is supported on the seat frame for its full width, whereas previously it was supported only at the center and ends. A lock-clip prevents the springs from slipping out of place. This is a Hudson development that is being copied by other manufacturers. In Hudson models, all coils are enclosed in burlap, which is double-stitched between the coils. Previously only two rows have been burlap-enclosed. Spring steel mattress wire over the tops of the coils prevents their puncturing the padding. Besides being more comfortable and longer-lived, the 1937 cushions are crowned and contoured to be more pleasing in appearance.

S

279 - *What kind of interior trim is used?*

Rich wood finish. The beauty of the door garnish mouldings on all Hudson models is enhanced by a graceful valance design.

S

280 - *What type of hardware is used?*

The hardware is of a graceful "three-step" design to harmonize with the complete car design. All interior hardware has a polished finish. Handle knobs are of grain-marked Tenite in Hudson models, and of Plaskon in Terraplane models. Exterior hardware is chromium plated.

S

281 - *Can all doors be locked from the inside?*

Yes. However, it is impossible for the driver to lock himself

D

outside of the car inadvertently. He can lock himself outside only by using the door lock key.

282 - *How many keys are required?*

Two. One for the car door and ignition; the other for the spare tire and baggage compartment and the package locker on the instrument board. Locks on doors and baggage compartment are thief-proof.

283 - *What instruments are in the instrument cluster?*

- D** A large, quick vision speedometer, a mileage meter, a gasoline level gauge, a water temperature gauge and Teleflash gauges for oil pressure and generator.

284 - *What other instruments are on the panel?*

- The rotary-button light switch, the finger-touch starter control, the ignition switch, the radio dial and operating knob. A front compartment floodlight is installed immediately behind the instrument panel and at the side of the package locker. (This light is not installed in the Terraplane De Luxe series.) This bulb is easily removed from and installed in its bracket, and, as it is on a 10 in. extension wire, it may be used as an emergency light within a limited range in the front compartment. This light also illuminates the interior of the parcel compartment through a hole in the side of the compartment. A reflector plate increases the illumination. Hudson Custom models have a cigar lighter on the instrument panel and in the right rear arm rest, and an electric clock in the parcel compartment door.
- D**

- D** **285** - *Why are Teleflash gauges used instead of the conventional ammeter and oil pressure gauges?*

The Teleflash lights are more conspicuous warning

signals. In 1937, they have been made larger and easier to see. The driver will not ignore them.

286 - *What is the parcel compartment capacity?*

1,002 cubic inches, as compared with 813 cubic inches in 1936 models.

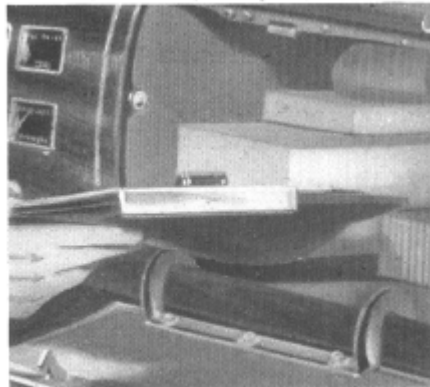

S

287 - *Is radio installed in any models?*

Six-tube, custom-type radio is

standard equipment in all Hudson Custom Eight models, and is optional at extra cost in all other models. Five-tube, de luxe type radio is optional at extra cost in all models except Hudson Custom Eight. Antennae are provided with radios purchased for installation in the field.

The parcel compartment has 1002 cubic inches capacity.

288 - *What type of antenna is used?*

It runs lengthwise under both running boards. It is completely waterproof and abrasion-proof, and is held by spring-tension hooks.

P

289 - *Is the radio built into Hudsons and Terraplanes, or merely "added" as an accessory?*

It is built in, in an inconspicuous, out-of-the-way position behind the instrument board and above the steering post, and does not prevent the installation of

P

a heater. The Hudson-built design for radio installation permits the best reception with the least electrical and mechanical interference.

The dial and operating knob are integral installations in the instrument board.

290 - *Will the radio exhaust the battery?*

No. (Refer to question No. 87.)

291 - *What type of headlamp is used?*

The two-beam type, with bright and dim beams operated by a convenient foot switch. The lamps are finished to match the fenders in all models.

292 - *Has any change been made in the illuminating capacity of the headlamps?*

Yes. The filaments have been relocated and the lens redesigned to control the illuminated area much better and consequently to provide more useful lighting. The driving beam has 75 per -cent more concentration, making it effective for a much greater distance. The foreground lighting of the passing beam is more concentrated-there is 50 per cent less stray. The passing beam is deflected 2 degrees to the right, giving complete illumination not only on the road, but also on the right shoulder. Both the driving and passing beams have approximately 50,000 candlepower. (Note - Mazda bulb No. 2331 should always be used with the 1937 headlamps.)

D

293 - *What other lighting equipment is there?*

All models have twin tail lamps (except Terraplane De Luxe, which has one). All tail lamps are in fender colors. The license plate is illuminated by a special light on the body "tail," just behind the center of the rear bumper.

All closed models have a dome light with a 15-candle-power bulb, giving probably the best illumination ever provided in an automobile interior. All models have indirect lighting at the instrument panel, and all (except Terraplane De Luxe) have a front compartment floodlight, which also illuminates the inside of the parcel compartment.

S **7**

294 - *What kind of horns is used?*

Twin electric-air horns on all models except Terraplane De Luxe, which has one vibrator-type. Horns are mounted on the forward side of the dash, under the hood. Outside horns are optional at extra cost.

D

295 - *Do Hmdsons and Terraplanes have safety glass?*

Safety glass is standard in windshields and front window wings. It is optional throughout all models at extra cost.

D

296 - *What type of windshield wipers is used?*

Vacuum-operated self-parking wipers, that go automatically to the "rest" position when not in use. The wipers oscillate from the bottom of the windshield, wiper giving a wider clear vision of the road. This is an important safety factor. All models have two wipers. Wiper arms and blades are of stainless steel.

D

297 - *What type of foot rest is used?*

In all models except Hudson Eight 129" w.b. Sedans, the foot rest for rear seat passengers is cut into the front seat back, giving a wide resting surface at the most comfortable angle. In 129" w.b. sedans, the foot rest is a metal bar, covered with carpet, which may be twisted slightly around the bar to expose an unworn portion whenever the carpet shows apparent wear.

S

298 - *What kind of floor carpet is used?*

S A heavy pile type. It is cushioned by a kersey silencer pad that is cemented to the floor.

299 - *What are the other interior appointments?*

S Pull-to grips on right-hand front doors of Hudson Eight Custom models.

Ash receivers as follows: One in instrument panel of all models; one in front seat back of all Terraplane, Hudson Six and Hudson De Luxe Eight (122" w.b.) Sedans; two in arm rests of Hudson Eight De Luxe (129" w.b.) and Hudson Eight Custom (122" and 129" w.b.) Sedans, and Hudson Eight Custom Broughams; one in rear quarter panel of all Terraplane Broughams; two in rear quarter panels of Hudson Six and Hudson Eight De Luxe Broughams.

Cord-type hangers on front seat backs of all Terraplane Sedans and on Hudson Eight Custom Broughams; metal bar hangers on all Hudson Sedans.

One assist strap in all Broughams (except Terraplane De Luxe) and two assist straps in all Sedans (except Terraplane De Luxe).

Folding-type sun visor in Terraplane De Luxe models and fully adjustable visor in all other models. Hudson Eight Custom models have two visors.

Non-glare rear-vision mirror.

300 - *Are the pedals convenient and comfortable?*

D Yes. The clutch, brake and accelerator pedals are conveniently placed and have a soft, easy action. The clutch pedal is insulated from the clutch shaft by rubber pads, preventing any engine movement from being transmitted to the pedal. Ribbed rubber pads cushion the feet and keep them

from slipping from the pads.

Rubber pads around the pedal rods cover the holes in the floor through which the rods run, and keep out drafts, motor fumes and dust.

301 - *What new developments in body finishes has Hudson made for 1937?*

A new high solid, low-viscosity lacquer-developed by Hudson's paint laboratory working in conjunction with paint manufacturers-will be used on all 1937 Hudsons and Terraplanes. Hudson is the first to use this improved lacquer on its complete line of cars.

The permanent protection afforded by a lacquer depends upon the depth of the color material which remains on the metal. Lacquers must be thinned before they can be sprayed successfully, but the thinner quickly evaporates, having added nothing to the final finish. The problem, therefore, has been to develop a lacquer which would require a minimum amount of thinner - i.e., a lacquer which would leave a maximum of color and protection material on the metal after the thinner has evaporated. The success with which Hudson has solved this problem may be judged by the fact that one gallon of the new high solid, low-viscosity lacquer requires less than one gallon of thinner in preparation for spraying, whereas the old type lacquer requires two gallons of thinner. As a result the lacquer finish on Hudson-built cars is deeper, and consequently more lasting. S

Hudson research men, cooperating with paint manufacturers have also developed a highly superior enamel for use on the standard black enamel fenders. Until now a common fault of all black fender enamel, including the best then obtainable which was used on

Hudson and Terraplane fenders, has been that sun and weather dulled the finish until in time it no longer could be restored by cleaners and polishes. At considerable expense for research and for basic changes in its large fender enameling department, Hudson introduces a new black enamel which compares very favorably with lacquer in having nearly perfect luster retention.

All finishes used on Hudson-built cars undergo thorough testing at Miami, Florida, where the sun's rays have been found to contain a stronger combination of ultra-violet and infra-red rays than any other accessible spot. As these two types of light rays are particularly destructive to colors and finishes, a six-months' weathering test in the vicinity of Miami is equal to a year's test in Detroit or other parts of the country. Hundreds of colors and finishes are tested in Florida for Hudson, but only those which meet a definite high standard of weathering resistance are accepted for use on Hudsons and Terraplanes.

302 - *How are exterior parts plated?*

S All shiny metal parts are chrome plated except the radiator grille and moulding, which are stainless steel.

303 - *What kind of hood ventilators are used?*

S Herring-bone louvres of the most modern type, harmonizing with the body design.

304 - *What type of hood lock is used?*

A single handle pull type, in the center of the lower edge of the hood. It is both hood-lock and hood-lift.

S **305 - *What type of fenders is used?***

Modern style fenders, with deeper, full-length crown.

The fenders are of heavy gauge steel, rigidly mounted on heavy brackets.

306 - *Of what value are the deep fender skirts?*

In addition to blending with the streamline design of the car, they conceal the under part of the chassis and also protect the body and running boards from road splash. Black enameled, fenders are standard on all models except Hudson Eight Custom models, which have fenders in body color. Fenders in body color are available in all other models at extra cost.

S

307 - *Are the fenders protected from rocks thrown by the wheels?*

Yes. A heavy rubber guard mounted beneath the fender crown behind each wheel prevents stones from striking and denting the fenders. It also atomizes water and mud splashed by the wheels and prevents the accumulation of mud beneath the fender, and the splashing of fender tops and running boards.

308 - *How are the radiator shells finished?*

In the body color.

S

309 - *How are the radiator grilles finished?*

Grilles and mouldings are stainless steel.

S

310 - *What tools are included in the original kit?*

Jack, jack extension handle, starting crank, spark plug wrench, monkey wrench, end wrench, hammer, pliers, screwdriver, wheel hub bolt wrench, shift lever with "Electric Hand" installation.,

311 - *Where are the tools kept?*

In the baggage compartment - car seats need not be moved or passengers disturbed to get them.

D

312 - *Where is the car serial number shown?*

In three places: (1) on the body plate, which is mounted on the right front hinge pillar for ready reference; (2) on the rear cross member of the chassis frame, near the right side member; (3) on the frame right side member above the rear of the front spring hanger.

OPTIONAL EQUIPMENT AND APPROVED ACCESSORIES

313 - *What additional equipment is optional at extra charge?*

Any of the following equipment may be specified at the time the order for the car is placed, and will be installed or built into the car at the factory:

Side Tire Mount: May be ordered on any model, and is especially desirable for those who wish the maximum carrying space of the luggage compartment or trunk.

Rear Wheel Shield: Available on all models; adds definitely to the streamlined beauty of the car.

Safety Glass: Standard in windshields and wind deflectors. Built into cars to be sold in states which require safety glass in all windows; available in all models to be sold elsewhere.

Leather Trim: Leather cushions, seat back and wall panels, standard on all convertible models; available in all other models and body types. Leather upholstery is increasingly used because of its excellent wearing qualities and its rich appearance.

Chrome Wheel Rings: Available on all models as an added touch of beauty for the wheels.

Chrome Wheel Discs (for 16" wheels): Standard on Hudson Eight Custom models, available on all other models; this disc, extending from the hub caps to the rim, forms a complete chrome finish disc wheel.

Twin Air Horns: Mounted on dash beneath the hood. Standard on all models except the De Luxe Terraplane, on which they may be ordered.

Twin Outside Horns: Air horns in chromium finish which may be mounted outside at the front of the car. Available on all models.

Custom Radio: See Question No. 287. Standard equipment on Hudson Custom Eight models; a 6-tube receiver with separate speaker. May be ordered on all other models.

De luxe Radio: See Question No. 287. A 5-tube receiver with integral speaker; may be ordered on all models except those having Custom radio as standard equipment.

Custom Steering Wheel: The 18" wheel, with three spokes, each of five stainless steel wires, and with Tenite rim and center, which is standard on all models except the De Luxe Terraplane, on which it may be ordered.

Electric Hand: See Question 128. Available on all models.

Automatic Clutch: See Question 124. Available on all models.

Vacuum Booster Pump: A combined vacuum booster and fuel pump, which provides additional vacuum for the steady operation of the windshield wiper.

Radio Antenna: See Question 287. Standard on Hudson Eight Custom models, which come equipped with

radio; included as equipment for cars ordered with radio.

Hydraulic Hill-Hold: See Question 211. A desirable safety device, which prevents the car from rolling backward on grades. Available on all models.

White Side Wall Tires: Available on all models for those who wish an added touch of smartness to the car.

15" x 7.00" Tires: For use on cars ordered with 15-inch wheels; available on all models.

Front Fender Lamp: For use on front fenders as parking lamps; available on all models.

Lacquered Fenders: With the exception of Hudson Eight Custom models, on which fenders matching the body color are standard, fenders are in black enamel only. They may, however, be ordered in body color on any model.

314 - What are Hudson Approved accessories?

Those items of added equipment which have been thoroughly tested by the Hudson Motor Car Company and are recommended for use on Hudson-built cars. These accessories must be obtained from an authorized Hudson and Terraplane dealer, as they are not installed at the factory.

A list of Hudson Approved accessories for 1937 follows:

Heaters: De luxe and Custom types, both engineered to meet the heating requirements of 1937 Hudson built cars.

Windshield Defroster attachment: Used in connection with either the Deluxe or Custom heater to carry a flow of heated air to the base of each windshield section, defrosting the inside of the glass and preventing the formation of ice on the outside.

Seat Covers: Tailored to fit the cushions and seat backs of the 1937 cars.

Draft Deflectors: May be added to Terraplane Commercial cars and the De Luxe Terraplanes to provide a draft deflector for the front windows. Turned outward, they become wind scoops for forcing air into the car on hot days.

Spot Light: Especially for installation on 1937 Hudsons and Terraplanes, with control handle inside, convenient to driver's left hand.

Fog Light: To be mounted singly, or in pairs, on the front bumper bracket. The amber light gives a safe and visible beam in fog or snowstorms when the head lamp beam is less efficient.

Tell-Turn Signal Lights: Mounted at the front and rear (rear light may be purchased singly), these lights give a vivid, flashing signal of the driver's intention to turn to either right or left. Operated from within the car by the driver, without necessity of opening window to make a turning signal in cold or stormy weather.

Safety Swinging Stop Lamp: At pressure on the brake pedal, this light swings and flashes, giving clear indication that a stop is being made.

Fender Guides: In reproduction of the radiator ornament, fender guides add smartness to the car, and serve the driver by indicating the outside clearance of either fender.

Outside Mirror: Attaches to the left-hand door post and safely eliminates the blind spot to the rear which cannot be covered by the rear view mirror.

Mirror Clocks: Either of two attractive types of clocks, integral with the rear view mirror, add greatly to the distinctive appearance of the front

compartment, and place the clock in a position where it may be safely read at a glance.

Vanity Mirror: An ample sized mirror, conveniently attaches to the sun visor where it can be used as desired without disarranging the rear view mirror.

License Plate Frames: Chromium plated frames, adjustable to fit any shape of license plate.

License Plate jewels: Red reflector buttons, attaching to the license plate, reflect oncoming lights when the car is parked with lights off.

Gas Tank Lock Cap: Prevents theft of gasoline and discourages theft of the car, as it is impossible to refill the tank without the key.

Tail Pipe Extension: Prevents corrosion and discoloration of the bumper by exhaust fumes, and adds to the appearance of the car. Made of chromium plated brass.

Right Hand Sun Visor: Protects the eyes of those sitting beside the driver.

Cigar Lighter: A practical necessity. Can be safely passed to others in the car.

Ash Receiver: For installation in the rear compartment, eliminating the danger of flying sparks and burned upholstery.

Assist Cord: In colors to match the upholstery of the car, assist cords contribute greatly to the convenience of rear seat passengers.

Door Pull-to: An attachment enabling passengers to pull the doors shut with a minimum of reaching.

Tail Lamp: An added lamp for the right side, providing twin tail lights on the Terraplane De Luxe models.

Electric Clock: Mounted in package compartment door.
Standard equipment on Hudson Custom Eight Sedans

8

315 - *When should extra cost optional equipment and Hudson Approved Accessories be sold?*

The best time for selling added equipment and accessories is when taking the order for the car. This is to the customer's best interest, especially if the car is being financed, as the equipment may be distributed throughout the payments on the unpaid balance, and will add little to the individual payments.

Certain equipment, such as heaters, windshield defrosters, etc., is seasonal, and owners should be contacted periodically for the sale of these items.

Use of the Hudson Approved accessories board in the sales room, as well as on the service floor, will increase the sale of accessories.

316 - *Are Hudson Approved Accessories better than other similar accessories on the market?*

Yes. There may be some accessories of equal quality, but Hudson Approved Accessories are better for use on Hudson-built cars because they are definitely engineered to operate most efficiently on Hudsons and Terraplanes. Each Hudson Approved Accessory has undergone thorough testing by the Engineering and Service departments to establish its superiority over similar accessories, and to make certain that it meets a high standard of quality.

With accessories as with cars, the ones selling cheapest are made to sell at a price, rather than to meet the best specifications of quality and performance.



117-Inch Wheelbase 96 and 102 Horsepower

Custom Panel Delivery

Cab Pick-Up

Station Wagon

Utility Coach

Utility Coupe

Chassis, with Cab

Utility Coupe Pick-Up

Canopy Express

TERRAPLANE commercial cars are designed and built to do more work for less money. Powered with a smooth 96 horsepower motor, proved for its rugged endurance and economical operation, with roomy bodies of far more than average capacities, these cars meet the demands of merchant, contractor, farmer, salesman, rural mail carriers or any profession or trade where powerful, economical service is essential.

With scientific power to weight design, Terraplane Commercial Cars do not haul extra pounds of useless weight. Hudson engineers have specified stronger, lighter, more expensive materials to attain this end.

Ruggedness of Terraplanes begins with the new Double Drop "2-X" Frame, which is wider, deeper and stronger . . . both riveted and welded. "Box" construction adds still further strength where stress is greater. The frame lowers the center of gravity without reducing road clearance-an important safety factor.

No other commercial car can offer all these qualities: Selective Automatic Shift, with improved Electric Hand (optional extra), Bodies all of steel, New Double Drop "2-X" Frame, Duo-Automatic Hydraulic Brakes, Hydraulic Hill-Hold, TruLine Steering, Direct-Acting Two-way Shock Absorbers, Heavy Duty Transmission, Oversize Rear Axle.

Eight body models, one standard and eleven optional colors.

PRINCIPAL SPECIFICATIONS

*Developed Horsepower	96
Bore and Stroke	3 x 5 inches
Displacement	212 cu. in.
Compression	6.2 5 to 1
A. M. A. Horsepower	21.6
Wheelbase	117 inches
Tires	16 x 6.00

*Super Power Dome available, stepping motors ahead to 102 horsepower.

TERRAPLANE CUSTOM PANEL DELIVERY - 117-In. Wheelbase

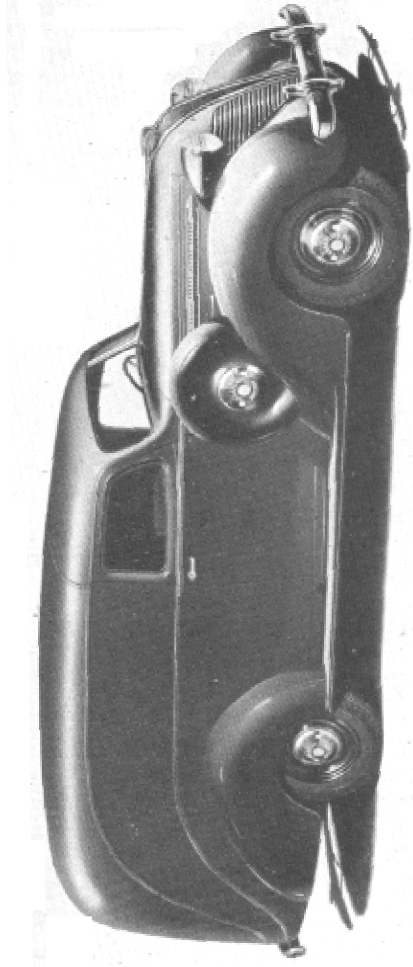

	<i>Delivered Price</i>	<i>Monthly Payments</i>
Custom Panel Delivery.....	\$	\$

TERRAPLANE CAB PICK-UP - 117-In. Wheelbase



	<i>Delivered Price</i>	<i>Monthly Payments</i>
Custom Pick-up.....	\$.....	\$.....

TERRAPLANE UTILITY COACH - 117-In. Wheelbase



	<i>Delivered Price</i>	<i>Monthly Payments</i>
Utility Coach.....	\$	\$

TERRAPLANE STATION WAGON - 117-In. Wheelbase

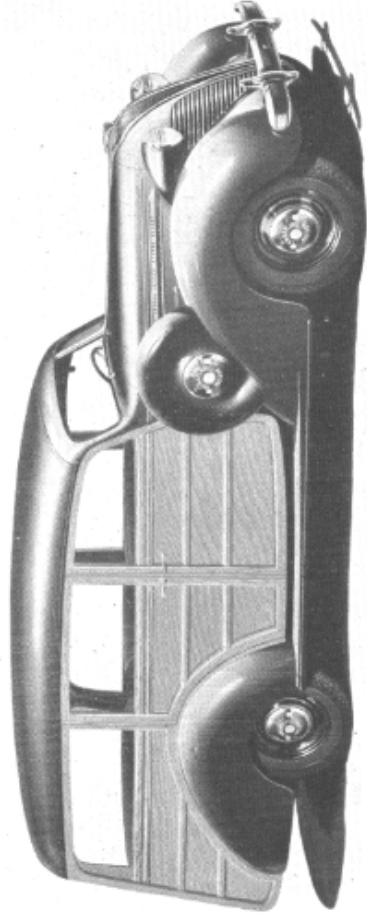

*Delivered
Price*

*Monthly
Payments*

TERRAPLANE UTILITY COUPE AND COUPE PICKUP - 117-In. Wheelbase

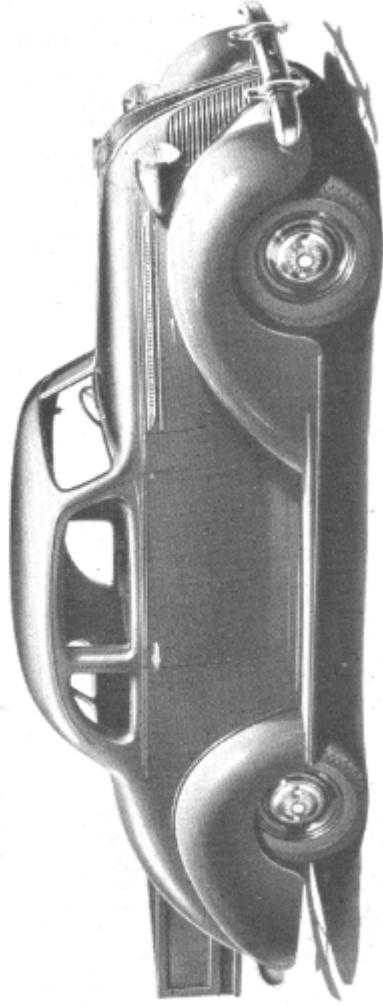

	<i>Delivered Price</i>	<i>Monthly Payments</i>
Utility Coupe.....	\$	\$
Utility Coupe Pick-Up	\$	\$

TERRAPLANE CHASSI WITH CAB - 117-In. Wheelbase

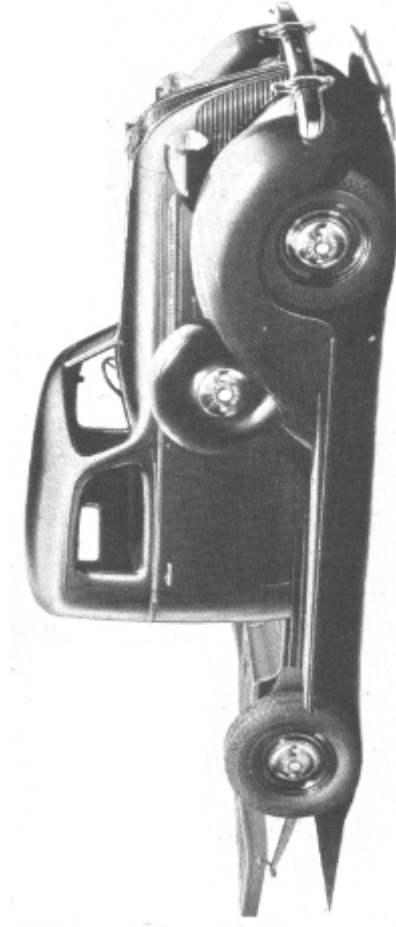

	<i>Delivered Price</i>	<i>Monthly Payments</i>
Chassis with Cab	\$	\$

**COMMERCIAL CARS
QUESTIONS AND ANSWERS**

317 - *What is a Commercial Car?*

A car used as a delivery **9** it having a rating of three quarters of a ton or less.

318 - What is meant by Commercial Car "rating"?

"Rating" means the load-carrying capacity of the car IN ADDITION to the weight of the chassis, cab, body and driver. Practically all Commercial Cars have a rating of one-half ton. In other words they are built to carry a load of 1,000 pounds.

319 - *What rating do Terraplane Commercial Cars have?*

Three-quarters of a ton or 1,500 pounds, in addition to the car and driver. This rating applies to the Custom Panel Delivery, the Cab Pick-up and the Station Wagon, but not to the Utility types such as the Utility Coach and the Utility Coupe, which have a half-ton rating.

320 - *What advantage has this higher rating?*

Greater economy. For example, a Cab Pick-up could haul a pile of gravel weighing 15,000 pounds in ten loads, A 1/2-ton car would require (at 1,000 pounds per load) fifteen loads.

321 - *How do the general dimensions of Terraplane Commercial Cars compare with others?*

Invariably larger in every way-longer, higher, wider, with more cubic feet of load carrying space - an advantage when bulky loads are carried, such as vegetables, laundry, dry cleaning, bakery goods, etc.
More room means more load can be carried.

322 - *What is meant by Terraplane's modern styling?*

Other Commercial Cars invariably have radiators, fenders, and body lines used one or two years previously in their passenger cars, whereas Terraplane uses the modern design of the 1937 passenger car, with its beautiful radiator, sweeping fenders, stream-lined hood, and distinctive appearance. The result is increased prestige and greater advertising value. Their styling is from one to three years ahead.

323 - *Does Terraplane have a complete line of Commercial Cars?*

Yes, generally speaking. Approximately 8070 of the needs of the light car delivery field are covered by our models.

324 - *Is there a large field for Commercial Cars?*

Yes - a tremendous field-vastly larger than is commonly realized. Practically all retailers, many contractors, small manufacturers, and the majority of rural industries use them. Wherever small loads have to be hauled, or deliveries made, there is a market for them.

325 - *Are Commercial Cars as "easy" to sell as passenger Cars?*

There is practically no difference. Many salesmen claim they are even easier. You simply sell a "car". As a rule the prospect knows just the type of body he needs. For example, if he has heavy, small loads to carry, such as sand, gravel, cement, machinery, etc., he would probably want a Cab Pick-up body. All you do is to apply the body type best suited to the buyer's needs.

326 - *Are Terraplane Commercial Cars new?*

A brand new line, completely redesigned, improved,

and bettered, is offered for 1937, but Terraplane has been building Commercial Cars for many years. Sales have grown to large proportions, and the line is being increased constantly to provide a wider coverage and greater opportunities for Dealers and Sales men.

327 - Will I have to know a lot of "engineering and technical specifications" in order to handle them successfully?

No more than you should know about your passenger cars. The mechanical specifications are practically the same, except the spring suspension, as Commercial Cars have to carry heavier loads. If you know your passenger car specifications you are qualified to answer all the ordinary inquiries a Commercial Car prospect will make, which are generally as to the performance, stability, economy and roominess of the car.

328 - What is the difference in mechanical specifications between Terraplane Passenger and Commercial Cars?

The major difference is in the spring suspension, which because greater load strains are placed upon them have been made much stronger. Commercial Cars have two additional leaves in the front and five additional leaves in the rear springs. The Pounds Per Inch of Deflection has been increased 155 pounds in the front and 295 pounds in the rear. Spring thickness gauge is 262 in front and 291 in the rear. They are equipped with self-adjusting "U" type shackles, and springs are covered to preserve initial riding qualities. These spring changes do not apply to the Utility Coach or Utility Coupe, which have slightly lighter springs.

329 - *What are some of the major mechanical specifications that Commercial Car prospects will be interested in?*

Power - 96 horsepower at 3,900 R. P. M.

Wheelbase - 117 inches.

Brakes - Three Braking Systems - Hydraulic, Mechanical and Emergency.

Frame - Over size - 300% stronger than formerly - Box type construction - Extra heavy cross members - Double X construction - Super rigid type - Withstands maximum stresses up to 5,000 pounds per square inch. Design permits lower loading height, and lower center of gravity and increased roadability.

Axle - Front axle "I" beam type-strongest used on any Commercial Car. $1\frac{1}{2}$ " x $2\frac{5}{32}$ ".

Rear axle built strong enough for car of 124 horsepower, and of the toughest steel used in the entire industry. Breakage practically unknown.

Steering - New design insures easy handling, without "road fight" even with heaviest loads. Largest king pin on any car of its type, $\frac{15}{16}$ " diameter. Sealed bearings. Constant lubrication.

Generator - Oversize, air-cooled type, more than capable of handling all demands made upon it.

Battery - Largest used in any Commercial Car - 17 plate, 105 ampere hours. Located under left front fender-protected against mud, water, dirt-accessible. Air cooled.

Loading Height - Lower than, or as low as, any similar cars.

Shock Absorbers - Direct-acting; cushion load to greater degree than "indirect type".

Lubrication - Only oiling system that has these three exclusive features

1. Provides oil the INSTANT the motor starts.
2. Provides cooled oil.
3. Provides quantity of oil in proportion-to engine needs-for instance, twice as much at 40 miles per hour as at 20. Three times as much at 60 miles per hour as at 20.

Power-to-Weight Ratio - Provides much more power in proportion to the weight of the car than other makes. Less pounds to haul per horsepower means more economy. Less "pulling" effort. Less dead weight. More gas used to haul actual load and less wasted on "dead weight". Less wear on bearings, tires, clutch and brakes. Less strain on transmission. Quicker acceleration. More reserve power. Easier and safer handling. All of these make for outstanding economy.

Dimensions - Carrying capacity of the body-length, height, width, cubic contents, overall length, dimensions of cab. Terraplane excels in practically all roominess dimensions.

Standard Equipment - Such as spare tire, tire cover, rear view mirror, instruments, order compartment, accessories. No similar models are more completely equipped, generally speaking.

Economy Features - This is most important. Every prospect will be interested in economy features. Extremely hard motor block, which means closer clearances, longer life. Four pinned piston rings, light weight

pistons, improved manifold design-efficient carburetion. More power per pound of weight carried. Finer materials. More efficient motor design. Economy in repair and upkeep are effected by the many strength factors built in Terraplane cars.

330 - *What are some of these strength factors?*

Rear Axle Housing has a strength factor of 20 to 1.

Propeller Shaft and Universal Joints have a strength factor of 14 to 1.

The Transmission Main Shaft has a strength factor of 10 to 1.

The Clutch Pilot Shaft has a strength factor of 20 to 1.

Frames have the ability to withstand maximum stresses up to 5,000 pounds per square inch.

Connecting Rod Bearings will stand up under a pressure of 82,000 pounds seven times as great as they will ever be subjected to.

331 - *What items are standard equipment on the instrument panel?*

The same as in De Luxe Terraplane passenger models. (See questions Nos. 283 and 284.)

332 - **What colors are available without extra cost?**

Refer to current Price and Equipment List.

333 - *What safety features will buyers be interested in?*

All steel cabs-on Cab Pick-up and Custom Panel Delivery. Bodies all of steel-on Utility Coach, Utility Coupe, Coupe Pick-up and Cab Pick-up. Safety glass windshields; also safety glass in front doors of Station Wagon, and in rear windows of Custom Panel Delivery. Triple strength, super-rigid frames. Three braking systems - hydraulic, mechanical

reserve and emergency. Low center of gravity. Balanced load distribution. Surplus power-higher power to weight ratio. High road clearance. Clear vision V-type windshield. Eye-level, visible instrument panel. Heavy, extra strong, spring suspension. Heavy-load steering control, with over-size king pin.

334 - *What comfort and convenience features will interest buyers?*

The extra roominess of the cab. The -V-- type windshield, which affords greater vision. The "eye-level" instrument panel. Completely sealed, weatherproofed doors. Order or package compartment on dash. Starter button on dash. Toe dimmer light switch. The Automatic Selective Shift (optional). Three position adjustable driver's seats. Sliding window ventilation (except in Station Wagon). Ash receiver on dash. Built-in defroster. Battery under left fender.

THE COMMERCIAL CHASSIS AND CAB

335 - What is the construction of the cab?

All steel throughout, with safety glass windshield. Bench type seat, extending the full width, upholstered in durable, waterproofed imitation leather and adjustable to three positions; sliding window ventilation; complete instrument panel with order compartment in dash; insulated floors and doors. Locks on inside of left hand door and on outside of right hand door. Rear view mirror. Every consideration has been given to the comfort and convenience of the driver.

336 - What are the dimensions of the cab?

From instrument panel to rear of cab - $36\frac{3}{8}$ inches.

Height of roof from floor - 49 inches. Width at floor $53\frac{1}{2}$ inches. Seat width - 55 inches.

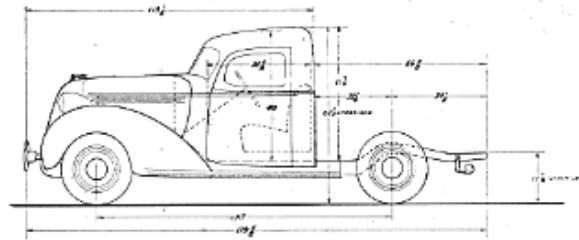

Important dimensions of the Chassis and Cab.

337 - *What are the dimensions of the chassis?*

From bumper guard in front to rear of cab - $113\frac{1}{4}$ inches. From rear of cab to center of rear axle - $32\frac{1}{2}$ inches. From center of rear axle to end of frame - $34\frac{1}{8}$ inches. Overall length - $179\frac{5}{8}$ inches. Floor of frame to top of cab - $51\frac{3}{4}$ inches. Width of frame at back of cab - 44 inches. Width of frame at rear, axle - $47\frac{1}{4}$ inches. Wheelbase - 117 inches.

338 - *Who are logical prospects for the chassis and cab?*

There are two major classes of prospects:

Those who have a body they want to re-mount on a new chassis;

Those whose business demands a special type of body which must be specially designed and built, but who will need a chassis, or with cab upon which to mount it.

THE UTILITY COACH

9

This is a regular passenger Brougham with the following body differences: The rear seat is removable, providing a clear load space from the rear compartment entrance. The right hand front seat may also be removed, providing still greater load space. There are masonite panels on the quarter windows. There are detachable covers of imitation leather on the lower side panels. Instrument panel is the standard Commercial Car panel.

It supplies the needs of the buyer who primarily wants a passenger car but who has to carry some loads, which can be carried in a body of this type.

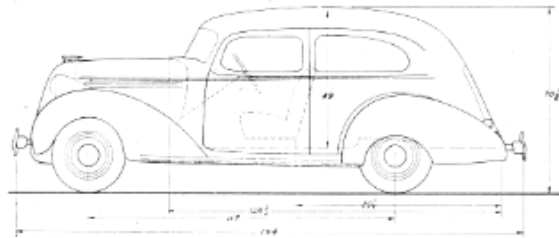

Important dimensions of the Utility Coach.

Width at floor - 53 inches. Length back of driver's seat to end of rear compartment at floor - $80\frac{1}{4}$ inches. Length from dash to end of rear compartment - $124\frac{1}{2}$ inches. Size of rear opening: height $28\frac{3}{4}$ inches; width - 44 inches. Load area with front right hand seat removed - 113.6 cubic feet.

339 - Who are logical prospects for the Utility Coach?

Traveling salesmen and small merchants who deliver their own goods are among your best prospects. For example,

example, salesmen who carry samples or demonstrators such as typewriters, cash registers, adding machines, scales, store fixtures, office equipment, oil burners, etc. Or salesmen and small merchants who carry supplies of tobacco, candy, floor coverings, novelties, paper, shoes, hats, dry goods, etc. Merchants who make only a few deliveries, but who can afford only one car for both personal and business uses, such as grocers, meat markets, vegetable and fruit dealers, plumbers, florists, printers, etc. Or rural industries such as orchards, hatcheries, growers, etc. Or people who live outside of a city or town and who need a car for general purposes, such as resort owners, road houses, country homes, wayside stands, taverns, etc. Rural mail carriers are ideal prospects. The Utility Coach is the ideal car where a personal passenger car is needed most of the time, with occasional need for a delivery unit.

THE CUSTOM PANEL DELIVERY

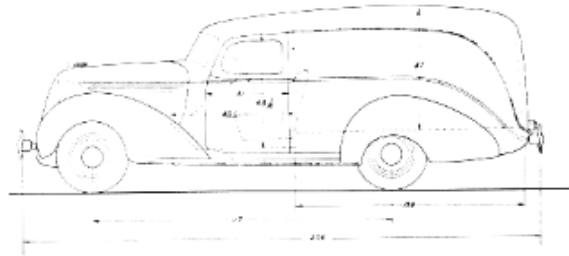

Important dimensions of the Custom Panel Delivery

340 - *What are the dimensions of the Custom Panel Delivery?*

Length of body, at floor - 89 inches. Width at belt - $58\frac{1}{2}$ inches. Width between wheel housings - $47\frac{5}{8}$ inches. Height to roof bows - 47 inches. Capacity of load area - 136 cubic feet. Width of rear door opening - 45 inches. Height of rear door opening - 36 inches. (Doors open full width of opening.) Cab height 49 inches at center. Cab width $56\frac{1}{2}$ inches; cab length- $48\frac{1}{4}$ inches dash to front of floor. Cab door opening - width 31 inches. Height - $4\frac{3}{8}$ inches.

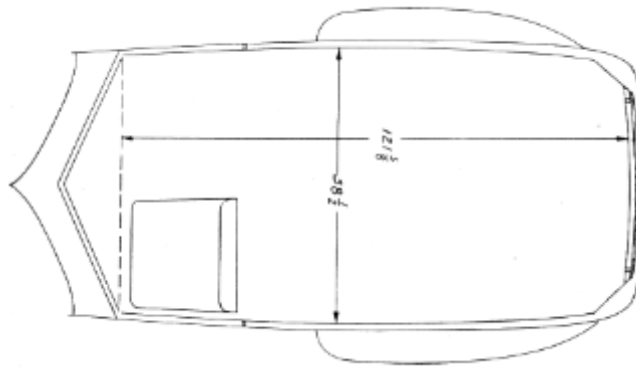

Plan view drawing of Custom Panel Delivery, showing body length and width.

341 - Who are logical prospects for the Custom Panel Delivery?

Retail merchants are among the best prospects grocers, meat markets, department stores, specialty shops, men's clothiers, furriers, dry cleaners, laundries, florists, household goods, etc. Also such businesses as newspapers, furniture dealers, office equipment, radio stores, hardware dealers, as well as

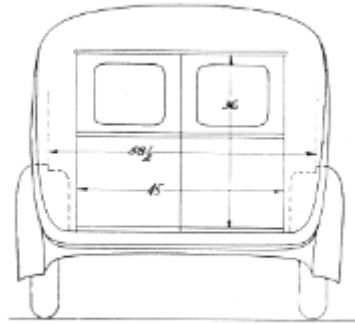

Rear door and body width dimensions of the Custom Panel Delivery.

some types of growers, fruit, vegetable and produce merchants, dairy products handlers, bakery goods, towel supply houses, tea and coffee firms, bottlers, office and store supplies, electrical fixtures, paint and wall paper dealers, awning manufacturers, etc. This model is

particularly adaptable where loads of some bulk, or which require protection against the weather, but are not too heavy, require transporting. It is a closed body, smart appearing, very roomy, and is adaptable for general delivery work.

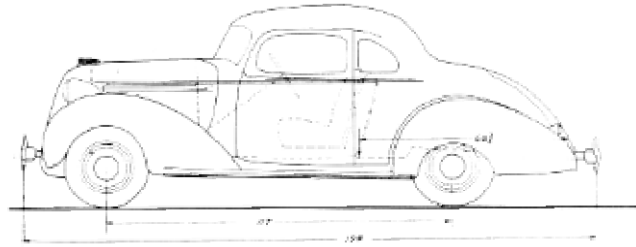

THE UTILITY COUPE

Diagrammatic side-view of the Utility Coupe.

342 - *What are the main differences between the Utility Coupe and the regular Passenger Coupe?*

1. Seat-Back of seat is divided, so that back folds forward, permitting easy access to compartment just in rear of seat.

2. Spare Tire Carrier-Spare tire is carried vertically in recess, or compartment, built just back of seat.

3. Rear Compartment-Top now opens from floor. There is no "sill" or obstruction above floor level, which permits load to "slide" in and out. By carrying spare tire in recess back of seat, the rear compartment is unobstructed, and provides large load area.

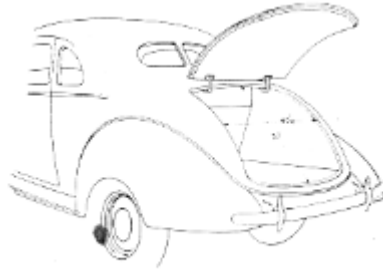

Loading dimensions of the Utility Coupe.

343 - *What are the dimensions of the rear opening?*

Width - 40½ inches. Height - 37 inches. Vertical height - 26 inches.

344 - *What are the dimensions of the compartment?*

Length - 66¾ inches. Width - 48 inches.

THE UTILITY COUPE PICK-UP

345 - *How does this model differ from the standard Utility Coupe?*

The rear compartment is fitted with a sliding open express, or pick-up, body. The unit fits into a "track" which bolts to the floor of the rear compartment. The body slides on this track, on the order of a filing cabinet.

When pushed forward, it is completely inside the rear compartment, and the top may be lowered, entirely hiding the pick-up unit. When extended it provides an ample loading space of the open box type. Ordinary loads may be carried with the top up. Where

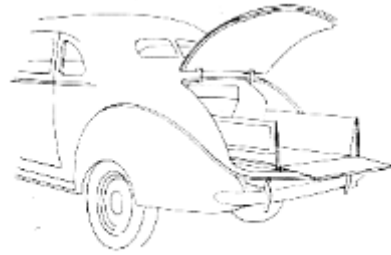

Utility Coupe Pick-Up, with pick-up unit extended.

unusually bulky loads are carried, the top may be taken off.

346 - What are the dimensions of the Pick-up body?

When fully extended, or opened: Length at floor - 49¼ inches. Width at floor - 38 inches. Height of sides - 11½ inches. Cubic contents of body-12½ cubic feet.

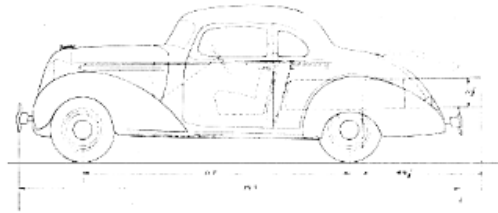

Diagrammatic side-view of the Utility Coupe Pick-Up, showing the pick-up unit extended.

Diagrammatic side-view of the Utility Coupe Pick-Up, showing the pick-up unit extended.

347 - Is there a tail gate on this Pick-up unit?

Yes, the end gate drops down on a level with the floor of the body, supported by covered chains, which form

a rigid support for it. When down it forms a loading platform. The general appearance and construction is quite similar to the regular body on the Cab Pick-Up.

THE STATION WAGON

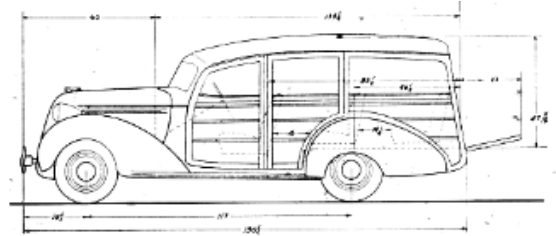

Important dimensions of the Station Wagon.

348 - *What is the general use and purpose of this model?*

This model provides passenger car transportation for as many as 8 persons, and is also adaptable for carrying miscellaneous loads. It has three seats-front for 3 passengers, center for 2, and rear for 3. Center and rear seats are removable, providing large load space. There are four doors, of the sedan type, beside a "tailgate," which drops to floor level, supported by covered chains, which forms a loading platform.

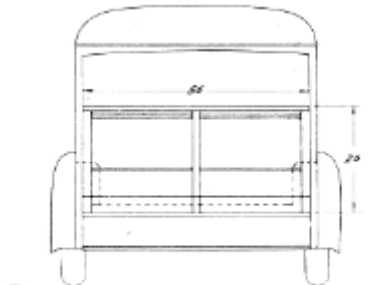

Rear view dimensions of the Station Wagon.

349-What are the body dimensions?

Height, floor to roof bows - $47\frac{11}{16}$ - inches. Width, at floor - 56 inches. Length, dash to tail gate - $134\frac{1}{4}$ inches. Overall, outside length - $196\frac{1}{2}$ inches. With rear seat removed, from back of center seat to tail gate - $46\frac{1}{2} \times 56$ inches. With center and rear seats removed, from back of front seat to tail gate - $85\frac{1}{2} \times 56$ inches.

350 - What are seat dimensions?

Width of aisle - $13\frac{1}{2}$ inches. From rear of front seat to edge of center seat - 16 inches. From rear of center seat to edge of back seat - $14\frac{1}{4}$ inches. From back of front seat to end of tail gate (when lowered) - $110\frac{1}{2}$ inches. Cubic load space with both seats removed 124.4 cubic feet.

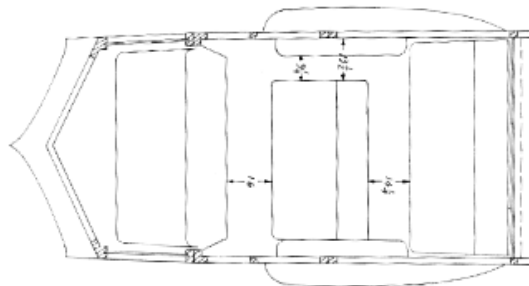

Plan view drawing of Station Wagon showing aisle and between-seat dimensions.

Plan view drawing of Station Wagon showing aisle and between seat dimensions.

351 - How is the body constructed?

Of selected, first grade maple, with fitted, dust-proof flooring; fabric top; two front doors with safety glass that lowers and raises; rear doors and open section

have storm-proof sliding curtains. Fenders, sheet metal, nails, screws, bolts, etc., rust-proofed. All outside woodwork finished in natural color. Tail light is recessed in body to give better streamlining effect.

Tail gate-55 $\frac{3}{4}$ x 26 inches; locks when up. Spare tire, with metal cover, in front fender. One of the most beautiful and most finely constructed bodies of its type on any Commercial Car.

352 - Who are logical prospects for the "Station Wagon"?

Where there is need for a car capable of carrying up to 8 persons, with some load space, or which may be converted to a fairly large load-carrying unit, the Station Wagon is the logical car. It has three seats, two of which may be removed, providing a large load space. Owners of summer homes, or estates, air ports, private schools, small hotels, small bus lines, resorts, sanitariums, hospitals, boat and railroad transfers, country clubs, surveying crews, road construction engineers, ranches, camps, summer schools, etc., are excellent prospects for this model.

THE CAB PICK-UP

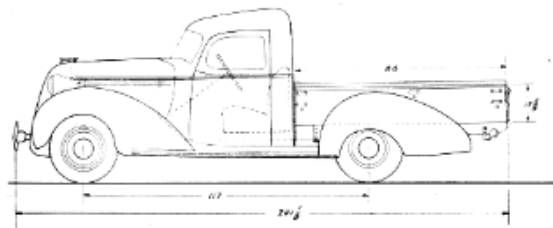

Side-view dimensions of the Cab Pick.-Up.

353 - What are the general uses of this model?

For hauling heavy but compact loads, that do not require protection from the weather. This type of body is variously called the "open express", the "express pick-up", "open pick-up" and the "cab pick-up". Its field is very large.

354 - What are the dimensions of the cab?

The same as those given in the Chassis and Cab section.

355 - What are the dimensions of the body?

The body is built with "lockers" which cover the wheel housings, thus providing a smooth, unobstructed loading space. These lockers may be easily removed, thus increasing the load space. However, even with the lockers installed (which is standard arrangement) the Terraplane load space compares favorably with other Commercial Cars. These lockers may be used for storing tools and equipment, or are convenient for use as seats when workers are being transported.

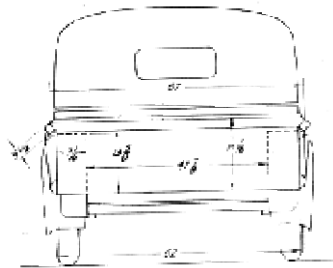

Important dimensions of the Cab Pick-Up.

Width of body between lockers at floor- $47\frac{7}{8}$ inches.

Length at floor - 86 inches. Height at locker sides $13\frac{7}{8}$ inches. Width with locker removed - 62 inches. Width between wheel housings, with lockers removed - $47\frac{7}{8}$ inches.

Width of flange at top of sides - $3\frac{1}{2}$ inches. Length of tail gate - $63\frac{1}{2}$ inches. Width of locker at top - $7\frac{7}{8}$ inches.

356 - *Who are logical prospects for the "Cab Pick-Up" model?*

Persons and firms having heavy, but not too bulky, loads to haul, such as: contractors, road builders, electrical and plumbing supplies, farmers, public utility companies, newspapers, magazine and periodical distributors, building supply houses, hardware dealers, radio and refrigeration dealers, retail coal and coke dealers, oil burner companies, office supply houses, floor covering firms, store fixture stores, painters, roofing firms, gardeners, marine equipment houses, machinery and parts houses, elevator firms, etc.

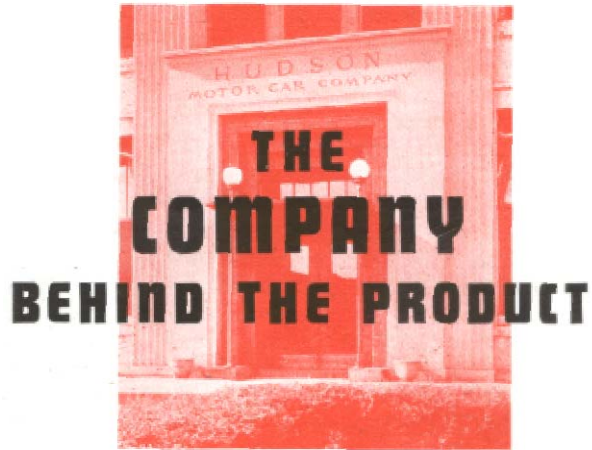

THE first Hudson to drive away from the Hudson Motor Car Company's production line in 1909 established the company as the industry's pacemaker in important engineering advancements. In its twenty-eight years of continuous service to the motoring public, Hudson never has relinquished this distinguished position. The fact that nearly four-score fundamental motor car features were introduced by Hudson is evidence of that. The better manufacturers in the industry have followed Hudson's lead in bodies all of steel, balanced crankshafts, aluminum alloy pistons and many other motor car developments. This year of 1937 has shown Hudson again creating trends for others to follow.

Quality, a Hudson pledge from the first, has become a tradition in the decades that have passed since 1909. Never has hurried engineering, cheap materials or questionable

workmanship gone into a Hudson-built car. Some two and a half million cars have been produced by Hudson. Half of them still are in service, including some of the first year's output. It takes quality to keep a motor car on the road 10 or 15 or 20 years or more. It requires stamina in a car to build up mileages of 100,000 or 200,000 or even 400,000. Hudson-built cars have such records ... not a few, but many of them.

The Hudson Motor Car Company has retained its personality as well as its tradition. The mammoth plant in Detroit covering 77 acres is under the active management of the company's principal stockholders. These men, many of them with Hudson since its founding, insist upon the production of the finest cars at the lowest possible price.

In talking to the prospective Hudson or Terraplane buyer, you can point with pride to Hudson's record and traditions. You can tell him that he is buying from one of the oldest companies in the industry, from a leader, from a company that can and will stand back of the product it builds.

QUESTIONS AND ANSWERS

357 - *Who manufactures Hudsons and Terraplanes?*

Hudson Motor Car Company, whose offices and factory are in Detroit, Michigan.

358 - *What experience has Hudson had in building automobiles?*

Twenty-eight years of experience. The Hudson Motor Car Company was founded in 1909. It has built more than 2,400,000 cars.

359 - *Has Hudson been an originator, or a follower, in motor car design?*

An originator from the beginning. Hudson developed the



The great factory, covering 77 acres, in which Hudson-built car are completely designed and manufactured: (center) main manufacturing and assembly section, (bottom) unit-steel body section, (top) gear and axle section.

first coach model, the first inherently balanced crankshaft, the first aluminum alloy pistons, and more than eighty other fundamental motor car features.

360 - *What about the Hudson management?*

The active management is in the hands of the company's principal stockholders, many of whom have been with the company since its early years.

361 - *Are Hudsons and Terraplanes high-priced cars?*

No. Despite their superiorities in size, performance, beauty and comfort, they are in the low and medium price fields.

362 - *Are they expensive or economical to run?*

Very economical. Their gasoline mileage will compare favorably with that of any cars in their price fields and,

even with their high-compression motors, they do not require premium gasoline. Oil is seldom needed between the normal changes. Because of the balanced weight and scientific springing, they are easy on tires. Many owners report from 20,000 to 30,000 miles on a single set of tires.

363 - *Is service easily available?*

Yes. There are distributors and dealers in every state in the Union and every province in Canada, located in towns and cities of all sizes. In addition, there are several hundred authorized service stations. Authorized service is available in practically every community. (Note The Hudson Motor Car Company's Owner Service Policy is reproduced on pages 181-193.)

364 - *What is Unit-Engineering?*

It is the complete co-ordination of every part of the automobile to produce a unified whole. In a Unit-Engineered Hudson or Terraplane, every part not only performs its own specific function, but co-operates with every other part in giving smooth, effortless, reliable performance. The Unit-Engineered Hudson-built car is not an assemblage of parts. It is a co-ordination of parts into a balanced unit - just as your head, arms, legs and torso are co-ordinated into a balanced, unit.

365 - *With Unit-Engineering, does each part perform just one function?*

No. Many perform two or more. For example: The steel instrument panel also serves as an extra cross member in the body, and the sheet steel cross member which gives such strength to the chassis also serves as the floor of the body - just as your hand serves for feeling, grasping, writing and many other functions.

This multiplicity of functions eliminates dead weight and increases efficiency. (A, C, E, P, R, S)

366 - *How can Hudson achieve Unit-Engineering?*

Because Hudson designs and builds its cars within one great factory which is chassis and body plant combined-the only factory of its kind in the country. Motor, body and chassis engineers do not design their respective parts of the car and then have them put together on an assembly line. Hudson's motor, body and chassis engineers work in co-ordination from first blueprint to finished car in designing and building a unit automobile.



HUDSON MOTOR CAR COMPANY'S OWNER-SERVICE POLICY

The Hudson Motor Car Co., desiring that every Hudson and Terraplane owner be thoroughly satisfied, and believing confidently that Hudson-built cars will give the utmost satisfaction, has adopted a most liberal owner-service policy.

The Hudson Service Policy is intended particularly to assure the proper care of and attention to the car during the first few thousand miles of its use. The care given to a car during this early critical period frequently determines the satisfaction (in performance, economy, comfort and long life) that the owner will get from it afterward.

FOLLOW-UP OF NEW CAR OWNERS

Dealers should establish a systematic procedure for following up each new car sale to see that the car is brought in frequently for inspection, lubrication and

minor adjustments. The first contact of this kind should be made within thirty days after the sale and, following this, the owner should be encouraged to bring his car in for lubrication on an average of every thousand miles.

USE GENUINE HUDSON AND TERRAPLANE PARTS

It is important to the car owner, the dealer and the Hudson Motor Car Co. that every owner be encouraged to use only genuine Hudson and Terraplane parts. The use of unauthorized parts usually leads to unsatisfactory performance and more costly future repairs and adjustments, thus damaging the prestige of Hudson-built products and directly restricting the dealer's and the manufacturer's opportunity for future profit. Because of its manufacturing volume and facilities, the Hudson Motor Car Co. can obviously make first grade parts more reasonably than any other manufacturer. Thus it is clear that parts cheaper in price may be of inferior quality. Since they endanger the car, they are in the long run more expensive.

COMPLAINTS

Reasonable complaints should be solicited from car owners and the causes of the complaints should be quickly rectified. This will do as much as anything else to keep the owner satisfied and friendly in order to avoid unreasonable complaints; salesmen must be extremely careful to make no promises which cannot be fulfilled to the letter. All promises should be on the side of moderation, so that the customer will receive all or more than he has been promised.

PARTS AND LABOR WARRANTY

Provisions of the Hudson Motor Car Co.'s owner service policy, which is intended to promote the servicing of Hudson and Terraplane cars on a basis of fairness to the purchaser, the dealer and the manufacturer, are briefly as follows:

1. A Written Warranty, having the first 90 days of ownership, or the first 4,000 miles of driving (whichever shall occur first), guarantees to every purchaser of a new Hudson or Terraplane car a more than liberal Service Policy.
2. Should Hudson or Terraplane parts or workmanship prove defective at any time during the warranty period, Hudson and Terraplane dealers will supply the parts and perform the necessary labor for replacement, free of charge.
3. Before delivery of new cars to purchasers, every Hudson and Terraplane dealer will determine that all pre-delivery conditioning operations, as shown in the pre-delivery inspection forms, have been completed.
4. During the initial driving period, the dealer who sells the car will furnish one major inspection of the car at the expiration of 500 miles of driving, or one at 500 miles and another at 1,500 miles, according to the model. (This distinction is in compliance with a provision of the Automobile Code.)
5. If a Hudson or Terraplane owner should change his residence or be touring in any part of the United States or Canada, he may be certain of the proximity of a Hudson and Terraplane dealer, and will receive the full benefit

of the Parts and Labor Warranty and of proper lubrication service from the dealer.

6. At the termination of the Warranty period, the owner is offered the facilities of one of the most efficient service organizations in the world, providing genuine Hudson and Terraplane parts at uniform list prices, and service labor, based on current flat rate prices.

SEASONAL SERVICE

In the spring and autumn, dealers should call attention of Hudson and Terraplane owners to the advisability of preparation of their cars for summer and winter driving. These minor and inexpensive adjustments not only assure more satisfactory performance, but they also prevent the necessity of more costly service work later on. This seasonal service attention is a most important factor in owner satisfaction.

OBLIGATIONS OF MANUFACTURER

The manufacturer is under the obligation to build at a fair price an automobile that is reliable, economical, slightly, and simple in operation; to issue adequate instructions for its care and maintenance; to fulfill all conditions of his warranty; to see that all distributors and dealers maintain competent service men at all times, capable of instructing the owner and repairing the car; to maintain a complete stock of repair parts at the factory; to fill all parts orders carefully and promptly; to see that all distributors and dealers maintain suitable stocks for filling orders without delay.

OBLIGATIONS OF DEALERS

The dealer is under obligation to maintain at all times a stock of genuine parts and to fill orders

promptly; to maintain a properly equipped service department and render prompt, efficient and economical service; to deliver new cars in accordance with factory instructions; to properly instruct the purchaser of a new car as to the care, maintenance and operation of the car; to keep in close touch with the owners of Hudson and Terraplane cars in his territory; to see that purchaser receives particularly full instructions about lubrication as covered by oiling chart; to do all in his power to maintain his car's prestige throughout his territory; to issue follow-up letters or cards from which it can be determined whether service work is entirely satisfactory to customer; to keep his service station clean, to treat customers with respect and courtesy at all times and to provide suitable comfort facilities for customers awaiting attention; to assist the factory in fulfilling conditions covered by the Warranty.

OBLIGATIONS OF OWNER

The owner of an automobile owes it to himself to familiarize himself thoroughly with instructions covering care and maintenance of his car and observe such instructions carefully; to exercise care and judgment in operation; to get instructions, repairs and service from Hudson and Terraplane authorized dealers insofar as possible, since Hudson and Terraplane dealers are fully familiar with Hudson and Terraplane cars and are therefore better equipped to handle repairs and adjustments. In every case, regardless of what the circumstances may be, the Hudson or Terraplane owner should feel free to call upon his dealer for advice regarding any automobile problem.

Warranty

"We warrant each new passenger automobile manufactured by us to be free from defects in material and workmanship under normal service, our obligation under this warranty being limited to making good at our factory any part or parts thereof, including all equipment or trade accessories (except tires) supplied by the car manufacturer, which shall, within ninety (90) days after making delivery of such vehicle to the original purchaser or before such vehicle has been driven 4,000 miles, whichever event shall first occur, be returned to us with transportation charges prepaid, and which our examination shall disclose to our satisfaction to have been thus defective; this warranty being expressly in lieu of all other warranties expressed or implied and of all other obligations or liabilities on our part, and we neither assume nor authorize any other person to assume for us any liability in connection with the sale of our vehicles.

"This warranty shall not apply to any vehicle which shall have been repaired or altered by other than an authorized Hudson and Terraplane Distributor or Dealer in any way so as, in the judgment of the manufacturer, to effect its stability or reliability nor which has been subject to misuse, negligence or accident."

HUDSON MOTOR CAR COMPANY
DETROIT, MICHIGAN, U. S. A.

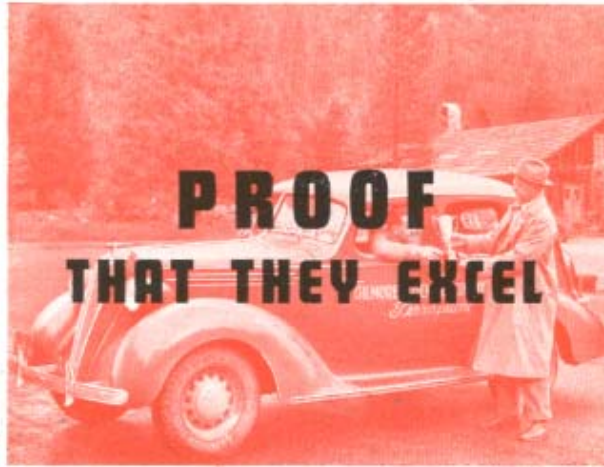

MORE officially certified American Automobile Association stock car performance records have been established and are held by Hudson-built motor cars than by any other line of automobiles. New marks have been set in acceleration, speed, hill climbing and long-run endurance records at high speed. Seventy eight such records, now held by Hudson-built motor cars are listed in tables on pages 199 and 200.

Add to these records the established economy of Hudson and Terraplane and you have motor cars of unchallenged leadership. In actual economy competition, Hudsons and Terraplanes have repeatedly beaten practically every other make of car.

Such records are important to the prospective purchaser of a Hudson or Terraplane even through he never expects to rush to the top of Mt. Washington in 13 minutes and will

not drive his car a thousand miles in eleven and a half hours. They are important because stock cars that will withstand the terrific tests to which Hudson-built cars have been subjected to make these records will have the performance to meet any road requirement. They have the stamina to keep their original "pep" and smoothness even after many thousands of miles.

Couple these records with astonishing economy and you have the complete range of Hudson and Terraplane performance.

Thousands of owners have voluntarily written to the factory telling of Hudson and Terraplane economy of gasoline, of low costs of repairs and of performance that would be remarkable in any other car. Many Hudson-built cars are still in service after 10, 15 and 20 years. Even some of the original 1909 models are still on the road. Astounding mileage has been built up in these cars . . . 150,000 miles, 200,000 miles and occasionally more than 400,000 miles have been recorded. Most of the original parts and equipment are still giving service in these veterans of Hudson's production lines.

Proving grounds for Hudson and Terraplane are the steepest hills of America and the well-known tracks where speed and stamina can be proved. We are reviewing here some Hudson and Terraplane Class C achievements-records which still stand. Remember that the 1937 Hudson-built cars are ahead of these proven champions in power and stamina.

DAYTONA BEACH RUNS

Seven new records for speed and acceleration were established at Daytona Beach by a Hudson Eight, with Sir Malcolm Campbell, of England, at the wheel. A new mark

new mark of 88.207 miles per hour was set for a one mile run with a flying start. From a standing start, the car accelerated through all gears to a speed of 68.18 miles per hour in one mile. In another significant test, a Hudson-built car covered one mile in second gear at 69.2 miles per hour from a standing start.

MUROC LAKE RECORDS

From the sun-baked bed of Muroc Dry Lake in California's Mojave Desert, came 36 new stock car records set by a Hudson Eight. (See table on page 199.) Among them a new speed mark of 93.03 miles per hour, the highest speed ever clocked for a closed car in Class C, made in a five-mile run. More significant is the astonishing 1,000-mile run. The distance was covered in 11 hours, 38 minutes and 55 seconds ... an average speed of 85.84 miles an hour. This record, made by a closed car, not only stands for Class C, but for closed cars of any class.

The Hudson Eight went on for hours after finishing the 1,000-mile test. With throttle wide open, it continued until the track became so filled with ruts that high speed driving no longer was safe.

ECONOMY TESTS

The Hudson Motor Car Company never has had to resort to mere claims ... proven facts easily match the claims of others. just as performance runs prove the stamina of Hudson-built cars, economy tests establish the fact that these fine cars do more work on less gasoline.

In one of the economy tests, Reid Railton, famous British automotive engineer and designer of Sir Malcolm Campbell's

"Bluebird" and John Cobb's "Napier-Railton", drove a Terraplane on the salt flats of Utah. In 1,000 miles of driving at 28 miles an hour, the Hudson-built car averaged 24.24 miles per gallon. Over the same distance at 50 miles an hour, it averaged 20.4 miles per gallon.

A member of the Contest Board of the American Automobile Association selected the Terraplane for this test. It was a stock car, chosen at random; one that had been driven thousands of miles by its owner. A regular grade gasoline was used.

Hudson and Terraplane dealers, following the policy of offering proof instead of claims, held their own economy runs. Hudson-built cars were driven in all climates and under all conditions and showed remarkable results in all.

BRAKES PROVE SUPERIOR

Duo-Automatic Hydraulic Brakes are better than the "perfect practice" referred to in engineering text books. This quick stopping ability of Hudson and Terraplane brakes was proved in a series of tests by the Hudson Motor Car Company and its dealers.

Dr. Alexander Klemin, in charge of the Guggenheim Laboratory at New York University, supervised a number of braking tests with a Hudson-built car. Stops were made at speeds from 10 to 50 miles an hour and in every instance previous records of stopping distance were lowered by a wide margin. For instance, at 20 miles an hour, police require a stop in 22.4 feet. The previous record was 18.1 feet. The Hudson stopped, according to Doctor Klemin, in 13.5 feet. Police supervised tests in Boston, San Francisco, Philadelphia, Norfolk, Akron, Denver, Portland, Me.,

Oakland, San Antonio, Sandusky, Albany, Los Angeles and many other cities. In many instances Hudson-built cars stopped in less than half required distances.

HILL CLIMBS

Hill climbing records, established by Hudson-built cars in 1933-and still unbeaten-are proof that Hudson or Terraplane can go over any hill on any improved highway in America in high. Hudsons and Terraplanes for 1937, having been stepped ahead in power, will take the hills in high with power to spare.

HUDSON 8 PERFORMANCE RECORDS—at Muroc Dry Lake, Cal.

11

Distance	Time	Speed in M. P. H.
1 kilometer	24.09 secs.	92.94
1 mile	38.83 secs.	92.70
5 kilometers	2 mins. 00.22 secs.	93.03
5 miles	3 mins. 13.50 secs.	93.02
10 kilometers	4 mins. 00.08 secs.	92.99
10 miles	6 mins. 48.91 secs.	88.04
25 kilometers	10 mins. 34.39 secs.	88.15
25 miles	16 mins. 59.89 secs.	88.24
50 kilometers	21 mins. 07.34 secs.	88.25
50 miles	33 mins. 56.78 secs.	88.37
75 kilometers	31 mins. 38.14 secs.	88.39
75 miles	50 mins. 56.03 secs.	88.35
200 kilometers	1 hr. 25 mins. 42.12 secs.	87.00
200 miles	2 hrs. 17 mins. 12.97 secs.	87.45
100 kilometers	42 mins. 11.19 secs.	88.35
100 miles	1 hr. 7 mins. 55.00 secs.	88.34
250 kilometers	1 hr. 46 mins. 48.40 secs.	87.27
250 miles	2 hrs. 53 mins. 16.92 secs.	86.56
300 kilometers	2 hrs. 7 mins. 56.91 secs.	87.42
300 miles	3 hrs. 27 mins. 24.80 secs.	86.78
400 kilometers	2 hrs. 52 mins. 17.32 secs.	86.56
400 miles	4 hrs. 37 mins. 17.71 secs.	86.55
500 kilometers	3 hrs. 34 mins. 40.78 secs.	86.83
500 miles	5 hrs. 47 mins. 26.31 secs.	86.35
1000 kilometers	7 hrs. 12 mins. 21.47 secs.	86.23
*1000 miles	11 hrs. 38 mins. 54.60 secs.	85.85
†1000 miles	11 hrs. 38 mins. 54.60 secs.	85.85
2000 kilometers	14 hrs. 51 mins. 45.85 secs.	83.61
†2000 kilometers	14 hrs. 51 mins. 45.85 secs.	83.61
3000 kilometers	22 hrs. 2 mins. 46.12 secs.	84.55
†3000 kilometers	22 hrs. 2 mins. 46.12 secs.	84.55
	1 hr.	88.34
	3 hrs.	86.61
	6 hrs.	86.38
Unlimited	12 hrs.	85.48

(Hudson Eight 5-Passenger Sedan, with full standard equipment, used in this test)

PERFORMANCE RECORDS—at Daytona Beach, Florida

Terraplane Sedan	1 kilometer	Standing Start	61.61
Hudson Sedan	1 mile	Standing Start	68.18
**Hudson Sedan	1 kilometer	Second Gear Only	70.319
**Hudson Sedan	1 mile	Second Gear Only	69.224
†Terraplane Sedan	1 kilometer	Standing Start	61.6

*Beats best mark of ANY closed car regardless of price or size.

†"Unlimited Class" means all cars, regardless of size or price. All other records shown here are Class C Records. Class C includes all American cars of 185 to 305 cubic inches piston displacement. Cars in this class are: Auburn, Buick, Chevrolet, Chrysler, DeSoto, Dodge, Ford, Graham, Hudson, Hupmobile, Lafayette, LaSalle, Nash, Oldsmobile, Packard 120, Plymouth, Pontiac, Reo, Studebaker and Terraplane.

**Performance certified by AAA; not provided for in AAA Register of Records

HILL CLIMBS

	Terraplane Record		Old Record	
	Min.	Sec.	Min.	Sec.
Lookout Mountain, Chattanooga, Tenn.	5	20.8	6	18
"W" Road to Walden's Ridge, Signal Mt., Chattanooga, Tenn.	4	9.8	4	37.1
Cameron Hill, Chattanooga, Tenn.	1	3.8	1	6
Eula St. Hill, Birmingham, Ala.	..	17.733	..	21
Osmoor Hill Shades Mt., Birmingham, Ala.	1	31.33	1	42.4
Gunter Hill, Montgomery, Ala.	..	23.9	..	27.4
Brown's Hill, Montgomery, Ala.	..	28.78	..	29.2
Stewart Ave., Atlanta, Ga.	..	38.67	..	44.4
Buena Vista Ave. Hill, Atlanta, Ga.	..	5 flat	..	10.8
Peterson Hill, Knoxville, Tenn.	..	10.8	..	12.8
Mill Mountain, Roanoke, Va.	1	38.13	1	43.8
Calawba Mountain, Salem, Va.	2	36.6	2	51.8
Summit Mountain, Uniontown, Pa.	2	47.6	3	15
Springfield Hill, Conneville, Pa.	..	41.8	..	55.8
Town Hill Mountain, Cumberland, Md.	1	30.54	1	52.4
Avonon Hill, Baltimore, Md.	..	22.133	..	23
Quaker Hill, Pimlico, Baltimore, Md.	..	46 flat	..	55.2
Saw Mill Road, Philadelphia, Pa.	..	37.1	..	46.8
Hermits Lane, Philadelphia, Pa.	..	26.73	..	30.4
Pt. George Hill, New York, N. Y.	..	24.2	..	24.8
Pt. Lee Hill, New York, N. Y.	..	48	..	49.4
Shingle Hill, West Haven, Conn.	..	23 flat	..	40.8
Mount Washington	13	33	14	49
Terraplane climbs from Base to Summit of Mt. Washington Sealed in High Gear
Big Cottonwood Canyon, Salt Lake City, Utah	24	54.9	27	18.2
Penitentiary Hill, Salt Lake City, Utah	..	36.6	..	38
Fillmore St. Hill, Santa Cruz, Calif. (High)
Wrightwood Canyon, San Bernardino, Calif. (High)	8	13.8	8	22.7
Mt. Baldy, Los Angeles, Calif. (High)	8	20.217	8	54.5
Mt. Baldy, Los Angeles, Calif. (Thru-gear)	8	20.217	8	44.25
Cushenbury-Johnson Grades, San Bernardino, Calif. (Thru-gear)	12	38.66	14	39.8
Cushenbury-Johnson Grades, San Bernardino, Calif. (High)	13	55.9
City Creek Canyon, near San Bernardino, Calif. (High)	20	58.9	21	35.7
City Creek Canyon, near San Bernardino, Calif. (Thru-gear)	18	12.8	19	55.15
Lower Waterman, near Los Angeles, Calif. (High)	3	13.47	3	20.4
Upper Waterman, near Los Angeles, Calif. (High)	11	32.95	12	14.75
Rim of the World, Los Angeles, Calif. (High)	12	54.25	13	42.10
Hollow Hill, near Los Angeles, Calif. (High)	..	25.49	..	25.75
Fish Creek Canyon Mt., near Phoenix, Ariz. (Thru-gear)	3	15.4	3	26.2
*Mt. Washington, near Gorham, N. H.	13	20 3/5	13	33 (held by Terraplane)

*This record made by Hudson Eight; all others by Terraplane.

SPECIFICATIONS

DE LUXE TERRAPLANE AND SUPER TERRAPLANE

12



ENGINE

De Luxe Terraplane:

Develops 96 h.p. at 3900 r.p.m., with 6.25 to 1 compression ratio. 102 h.p., with 7 to 1 aluminum cylinder head optional at extra cost.

Super Terraplane:

Develops 101 h.p. at 4000 r.p.m. With 6.25 to 1 compression ratio. 107 h.p., with 7 to 1 aluminum cylinder head optional at extra cost.

Bore 3"; stroke, 5".

Piston displacement, 212 cubic inches.

A. M. A. horsepower rating, 21.6.

Pistons, silicon aluminum T-slot cam-ground type with four pinned rings.

Connecting rods drop forged.

Patented crankshaft, fully compensated, drop forged, statically and dynamically balanced, with integral counter-weights insuring extreme smoothness.

LUBRICATION

Patented Duo-flo system with positive oil feed at all temperatures.

Labyrinthian oil cooling.

Oversize dual oil pump.

Oil reservoir refill capacity, 5 qts.

CARBURETION

De Luxe Terraplane:

Downdraft system with manual choke and heat control.

Super Terraplane:

Double downdraft system, with automatic choke and thermostatic heat control.

Back-fire arrester.

Air cleaner.

Dash pot throttle control.

Vapor-lock relief valve.

Automatic manifold drain valve.

IGNITION

Full automatic advance.

Metric spark plugs.

Moisture-proof distributor.

17-plate battery, 105 ampere-hour capacity.

Octane adjustment.

GENERATOR

De Luxe Terraplane

Extra capacity affords ample reserve capacity.

Voltage regulator installed if equipped with radio.

Super Terraplane:

Special extra-capacity ventilated type with voltage regulator affords ample reserve capacity for radio and other electrical appliances.

STARTER

Finger-touch control solenoid switch,

FUEL SYSTEM

Rear mounted gasoline tank - 16½ gallons

New extra large capacity, constant pressure fuel pump with glass bowl sediment trap.

Large fuel lines cooled to prevent vapor lock.

Level gauge on dash.

Uses non-premium fuel.

COOLING SYSTEM

Centrifugal, six-blade pressure pump driven by V-belt.

Silent fan.

Water temperature indicator on dash.

Cooling system capacity, 12½ quarts.

SELECTIVE AUTOMATIC SHIFT

Combination of the Electric Hand and the new, improved automatic clutch, optional at extra cost. Provides automatic shifting to any gear at any speed.

CLUTCH

Triple-scaled, oil-cushioned, single plate type with heat-treated cork inserts for smooth engagement and durability. Soft pedal pressure. New automatic clutch available as optional equipment at extra cost.

TRANSMISSION

Synchro-shift type-three speeds forward, one reverse-with silent gears for slow or fast shifting. The Electric Hand, for pre-selective power-controlled gear shifting. Optional equipment at extra cost. Automatic disengagement of low and reverse gears while in other gears or neutral. Interlocks prevent accidental slipping from gear mesh in any speed. Oversize ball thrust bearing with needle pilot bearing for main shaft.

UNIVERSALS

Two roller bearing universals with larger tubular propeller shaft.

REAR AXLE

Semi-floating type with nickel molybdenum steel gears and shaft. Spiral bevel final drive. Standard ratio, 4-1/9 to 1.

SPRINGS

Long semi-elliptic type front and rear; front springs shackled at both ends. Rear springs have splayed mountings for transverse stability, eliminating roll, and sway. U-type self-adjusting spring shackles. Longer improved oil-cushioned shock absorbers, adjustable for any type of ride desired. Direct action type. Radial Safety Control with softer, smoother springs designed only for suspension of car, and not for torque duty. Super Terraplane: Springs covered to preserve initial riding qualities.

BRAKES

Duo-Automatic Hydraulic brakes. Internal expanding two-shoe design on all four wheels. Supplementary mechanical service-brakes, steel cable operated, with mechanical equalizer, on rear wheels. Brake diameter, 101/16 - brake width, 1 1/4". Parking brake, steel cable operated. on rear wheels, with mechanical rotary equalizer. Hand brake lever under cowl. Hydraulic Hill-Hold optional at extra cost.

STEERING GEAR

Worm and Roller tooth type, with external adjustment; reduction 18.2 to 1. Timken roller front wheel bearings. De Luxe Terraplane: 17" steering wheel with natural finger grip. 18" spring spoke steering wheel optional at extra cost. Super Terraplane 18" spring spoke, Tenite rim, steering wheel with natural finger grip.

FRAME

Rigid, deep (7/4") 2X double drop type, with tensile strength at points of greatest stress. Entire rear structure of frame stiffened by heavy plate cross member forming floor of body, providing unit-steel construction of body and chassis.

WHEELS

16" steel balanced drop center type.

TIRES

Oversize low-pressure type-16 x 6.00". 15 x 7.00" wheels and tires optional at extra cost. White sidewall tires optional at extra cost.

WHEELBASE

117" wheelbase; overall length 194 1/2" bumper to bumper.

BODY

Steel roof, steel floor and a body structure of steel, reinforced WA steel; roof and body a solid sheet of steel. Completely insulated Box-girder type construction with Double structure throughout, reinforced at forward end by double bulkhead formed by dash and cowl. Instrument panel provides rigid cross member. Rear compartment houses tire and provides abundant luggage space:

Without Tire With Tire

Luggage		
Compartment	16½ cu. ft.	9½ cu. ft.
Trunk	19 cu. ft.	12 cu. ft.

Safety glass standard in windshield and wind deflectors and available at extra cost for all windows.

BODY VENTILATION

De Luxe Terraplane:

Two-way sliding window-type ventilation.

Super Terraplane:

Fore portion of front windows adjustable as draft deflectors, or turn farther outward to become wind scoops.

Automatic draft eliminator for winter driving; filtered air inlet.

Rear-quarter windows open longitudinally, providing vacuum air exhaust.

Controls under windows.

Large cowl ventilator, insect screen standard.

Welded body seams sealed with rubber compound.

LIGHTS

Headlamps streamlined to accord with body; approximately 50,000 candlepower.

Toe switch on floor board for driving or passing beams.

Indirect lighting on instruments.

De Luxe Terraplane: Tail lamp on left rear fender.

Super Terraplane:

Twin tail lamps.

UPHOLSTERY

Boucle or Mohair upholstery in closed models - leather standard in convertible coupe and convertible brougham, optional at extra cost in other body types.

Form-fitting seats and back cushion.

Upholstered arm rests in rear seat.

EQUIPMENT

Ash receiver in all body types.

Generous package locker; 1002 cubic inches capacity.

Adjustable sun visor.

Fenders lacquered in body color, extra cost option.

Robe cord in sedan.

Shim-adjustable steering column.

Twin vacuum windshield wipers.

Rear vision mirror.

Speedometer.

Fuel level gauge.

Water temperature gauge.

Safety signal instruments for oil pressure and charging rate.

Foot rest.

Complete thief-proof lock equipment for doors and rear compartment.

De Luxe Terraplane:

Single vibrator type horn under hood.

Twin air horns, outside or inside mounting, optional at extra cost.

Super Terraplane:

Twin air horns mounted under hood.

Twin air horns, outside mounting, optional at extra cost.

Radio: De Luxe 5-tube type, or Custom 6-tube type, optional at extra cost.

Combined vacuum booster and fuel pump, extra cost option.

NOTE - *The Hudson Motor Car Company reserves the right to make changes in car design, equipment or color schemes at any time without incurring any obligation to install same on cars previously sold.*

SPECIFICATIONS

HUDSON EIGHT

ENGINE

122 horsepower 8-cylinder L-head type.
Bore, 3"; Stroke, 4½".
Piston displacement, 254.47 cubic inches.
A. M. A. horsepower rating, 28.8.
Develops 122 horsepower at 4200 r.p.m.
Compression ratio, 6.25 to 1.
Pistons silicon aluminum T-slot cam-ground type with four pinned rings.
Connecting rods drop forged.
Patented crankshaft, fully compensated, drop forged, statically and dynamically balanced, with integral counter-weights, insuring extreme smoothness.

LUBRICATION

Oil reservoir refill capacity, 7 quarts.

BATTERY

19-plate battery, 125 ampere-hour capacity.

COOLING SYSTEM

Radiator capacity, 20 quarts.

BRAKES

Brake diameter, 11¹/₁₆"
Brake width, 1¾".

TIRES

Oversize low-pressure type, 16 x 6.2 5 inch. 15 x 7.00 tires at extra cost.

WHEELBASES

122 and 129 inches.

VENTILATION

Fore portion of front windows adjustable as draft deflectors, or turn farther outward become wind scoops. May be lowered into doors, if desired, an exclusive Hudson feature.

HUDSON SIX

ENGINE

101 horsepower, 6-cylinder, L-head type.
Bore, 3; Stroke, 5".
Piston displacement, 212 cubic inches.
A. M. A. horsepower rating, 21.6.
Develops 101 horsepower at 4000 r.p.m.
Compression ratio, 6.25 to 1.
Optional horsepower, 107 h.p. With 7.00 to 1 compression ratio.
Pistons, silicon aluminum T-slot cam-ground u type with four pinned rings.
Connecting rods drop forged.
Patented crankshaft, fully compensated, drop forged, statically and dynamically balanced with integral counter-weights, insuring extreme smoothness.

LUBRICATION

Oil reservoir refill capacity. 5 quarts.

BATTERY

17-plate battery, 105 ampere-hour capacity.

COOLING SYSTEM

Radiator capacity, 12½ quarts.

BRAKES

Brake diameter, 11¹/₁₆"
Brake width, 1¾".

TIRE

Oversize low-pressure type, 16 x 6.00 inch. 15 x 7.00 tires at extra cost.

WHEELBASE

122 inches.

VENTILATION

Fore portion of front windows adjustable as draft deflectors, or turn farther outward to become wind scoops.

Specifications Which Are Uniform in the Hudson Six and Hudson Eight

12

LUBRICATION

Patented Duo-flo system with positive oil feed at all temperatures.
Labyrinthian oil cooling.
Oversize dual oil pump.

CARBURETION

Double down-draft system, fitted with automatic choke and thermostatic heat control.
Air cleaner.
Back-fire arrester.
Dash pot throttle control.
Vapor-lock relief valve
Automatic manifold drain valve.

IGNITION

Full automatic advance
Metric spark plugs.
Moisture-proof distributor.
Octane adjustment.

GENERATOR

Special heavy-duty, extra-capacity, ventilated type with voltage regulator.

STARTER

Push-button control, solenoid actuated heavy-duty type.

FUEL SYSTEM

16½ gallon, rear mounted gasoline tank.
New extra large capacity, constant pressure fuel pump with glass bowl sediment trap.
Large fuel lines cooled to prevent vapor lock.
Level gauge on dash.
Uses non-premium fuel.

COOLING SYSTEM

Centrifugal, 6-blade pressure pump driven by V-belt.
Silent fan.
Thermostat by-pass control of water circulation.
Water temperature indicator on dash.

SELECTIVE AUTOMATIC SHIFT

Combination of the Electric Hand and the new, improved automatic clutch, optional at extra cost, provide automatic

shifting to any gear at any speed.

CLUTCH

Triple-sealed, oil-cushioned, single plate type, with heat-treated cork inserts for smooth engagement and durability.
Soft pedal pressure.
New automatic clutch available as Optional equipment at extra cost.

TRANSMISSION

Synchro-shift type - three speeds forward - one reverse (with silent gears for slow or fast shifting).
The Electric Hand for pre-selective power controlled gear shifting. Optional equipment at extra cost.
Automatic disengagement of low and reverse gears while in other gears or in neutral.
Interlocks prevent accidental slipping from gear-mesh in any speed.
Oversize ball thrust bearing with needle pilot bearing for main shaft.

UNIVERSALS

Two roller bearing universals with tubular propeller shaft.

REAR AXLE

Semi-floating type with nickel molybdenum steel gears and shaft.
Spiral bevel final drive.
Standard ratio, 4-1/9 to 1.

SPRINGS

Longer semi-elliptic type front and rear; front springs shackled at both ends.
Rear springs have splayed mountings to materially increase spring space by transverse stability, eliminating roll and sway.
U-type self-adjusting spring shackles.
Springs covered to preserve initial riding qualities.
Longer improved oil-cushioned shock absorbers, adjustable for any type of ride desired. Direct action type.
Radial Safety Control with softer, smoother springs designed only for suspension of car, and not for torque duty.

BRAKES

Duo-Automatic Hydraulic brakes.

Internal expanding two-shoe design on all four wheels.

Supplementary mechanical service brakes. steel cable operated, with mechanical rotary equalizer on rear wheels. Parking brake, steel cable operated, on rear wheels. with mechanical rotary equalizer.

Hand brake lever, under left front cowl-finger touch release.

Hydraulic Hill-Hold optional at extra cost.

STEERING GEAR

Worm and Roller tooth type with external adjustment.

Reduction, 18.2 to 1.

Timken roller front wheel bearings.

18" spring-steel spoke, Tenite rim steering wheel with natural finger grip.

FRAME

2X double drop type, 73/8" deep, with triple strength at points of greatest stress, Entire rear structure of frame stiffened by heavy plate cross member forming floor of body, providing unit-steel construction of body and chassis.

Front frame structure carries engine mounting of rubber.

WHEELS

16" steel, balanced drop center type.

15 x 7.00 tires and wheels optional at extra cost.

White sidewall tires an extra cost option.

BODY

Steel roof, steel floor and body structure of steel, reinforced with steel; roof and body a solid sheet of steel.

In unit with chassis - unit-construction principle utilizes floor of body as plate cross member of frame, giving unmatched rigidity.

Completely insulated and constructed throughout of steel in Hudson factory.

Box girder type construction with double structure throughout, reinforced at

forward end by double bulkhead formed by dash and cowl.

Instrument panel provides rigid cross member.

Rear compartment houses tire and provides abundant luggage space - 12¹/₃ cubic feet; 16³/₄ cubic feet with trunk model.

Safety glass standard in windshield and wind deflectors and available for all windows.

Automatic draft eliminator for winter driving; filtered air inlet.

Rear quarter windows open longitudinally, providing vacuum air exhaust.

Control under windows.

Welded body seams sealed with rubber compound.

LIGHTS

Headlamps streamlined to accord with body; approximately 50,000 candle power.

Toe switch on floor board for driving or passing beams.

Indirect lighting on instruments.

Front compartment floor light behind cowl, with extension cord.

Twin tail lamps.

UPHOLSTERY

Plain twist in De Luxe Hudson 8 and Custom Hudson 6 closed models; Knobby Twist in Hudson Custom 8 closed models; mohair optional in all closed models except Hudson Custom Eight, leather standard in convertible coupe and convertible brougham, optional in other body types at extra cost.

Form-fitting seats and back cushion.

Upholstered arm rests in rear seat.

EQUIPMENT

Ash receiver in all body types.

Generous package locker; 1002 cubic inches capacity.

Two sun visors in Hudson Custom Eights.

Shim-adjustable steering column.

Twin vacuum windshield wipers.

Rear vision mirror.

Speedometer.

Fuel level gauge.	Complete thief-proof lock equipment for doors, package locker and rear compartment.
Fenders lacquered in body color standard on Hudson Custom Eight models, extra option on other models.	Twin air horns under hood.
Roof rail in sedans.	Twin outside mounted air horns, extra cost option.
Custom radio standard equipment In Hudson Custom Eight models De Luxe 5-tube type, or Custom 6-tube type, optional in other models.	Electric clock standard in Hudson Custom Eight models.
Water temperature gauge.	Combined fuel pump and vacuum booster, extra cost option.
Safety signal instruments for oil pressure and charging rate.	Cigar lighter in instrument panel on Hudson Custom Eight models. In arm rest on Hudson Custom Eight models and in 129" Hudson De Luxe sedan.
Assist straps.	
Foot rest.	

NOTE - The Hudson Motor Car Company reserves the right to make changes in car design, equipment or color schemes at any time without incurring any obligation to install same on cars previously sold.

INDEX TO QUESTIONS

	<i>Question</i>
Air Cleaner	74
A. M. A. Horsepower	13, 14
Anti-friction Bearings	228
Automatic Choke	80 to 83
Automatic Clutch	122 to 127, 145
Automatic Draft Eliminator	265 to 267
Axle (front)	162, 213
Axle (rear)	173,174,216,217
Baggage Compartment	272,273,275
Battery	87, 92 to 94
Body Capacity	242
Body Construction	249 to 258, 261 to 263
-Insulation	255,256,262
-Streamlining	270
Body Models	239
Bore and Stroke	4
Brakes	193 to 212
-Parking Brake	209, 210
Bumper	229
Camshaft	52 to 54
Bearings	54, 55
Car Cost and Maintenance	361, 362
Carburetor	64 to 76, 81, 83
Carpet	298
Clutch	133 to 141, 143, 144
Commercial Cars	See special index.
Compression	6,8

	<i>Question</i>
Connecting Rods	48 to 51
Cooling System	112 to 121
Cowl Ventilator	269
Crankcase	25, 26
-Ventilation	25
Crankshaft	31 to 36
-Damper	36
-Main Bearings	37 to 39
Custom Equipment	241
Cylinder Block	19 to 24
Cylinder Heads	6,8
Defroster	270
Displacement	5, 9, 11
"Electric Hand"	122, 124 to 126, 128 to 132
Engines	1 to 150
Engine Mounting	27 to 30
Engine Number	18
Fan	121
Fenders	305 to 307
-Brackets	305
Foot Rest	297
Frame (chassis)	154 to 161
Fuel Pump	75
Gasoline Tank	84
Generator	85 to 89
Hardware	280
Hood Lock	304
Hood Ventilators	303
Horsepower	7, 9, 139 14
Hotchkiss Drive	222, 223
Hudson Motor Car Company	357 to 360
Instruments (and Panel)	283 to 286
Interior Appointments	299
Lengths (car overall)	152
Lights	291 to 293

	<i>Question</i>
Locks	281, 282
Lubrication (chassis)	227
Main Bearings	37 to 39
Manifold	77, 78
Muffler	233, 234
Oiling System	98 to 111
-Pump	104, 106
-Labyrinthian Plan	103
-Oil Tray	103
-Refill Capacity	110
Paint	301
Parcel Compartment	286
Pedals	300
Piston	40 to 47
-Rings	41 to 43
-Wrist Pins	47
Power-to-Weight Ratio	15 to 17
Pre-Selection	128 to 130
Propeller Shaft	221 to 223
Radial Safety Control	162
Radiator	112, 113
-Grille	309
-Shell	308
Radio	287 to 290
Road Clearance	237
Road Levellers	177 to 184
Running Boards	230 to 232
Safety Glass	295
Seats (adjustable)	244 to 246
Seat Cushions	278
Serial Numbers	312
Service Stations	363
Selective Automatic Shift	122 to 127
Shackles	175
Shock Absorbers	(See Road Levellers)

<i>Question</i>	
Spark	95, 97
-Plugs	96
Springs	163 to 166, 169 to 172
-Covers	176
-Shackle	175
Steering Gear	185 to 188, 214
-Ratios	187
-Column	188
-Wheel	189 to 191
Super Terraplane Equipment	240
Tappets	56 to 58
Teleflash Signals	283, 285
Thermostatic Water Heat Regulator	113, 115, 116
Tires	225, 226, 272, 274, 276, 313
Tools	310, 311
Transmission	146 to 150
Tread	153
Trim	219
Trunk Models	274, 275
Turning Radius	192
Upholstery	277
Unit Engineering	364 to 366
Universal joint	220
Valves	59 to 61
-Seats	20 to 22
-Springs	62, 63
Vapor Lock Elimination	75, 76, 79
Ventilation	264 to 269
Water Capacity	112
Water Temperature Indicator	120
Water Pump	113, 117 to 119
Wheels	224
Wheelbase	151
Windshield Wiper	296
Wrist Pins	47

INDEX
T 0
COMMERCIAL CAR
QUESTIONS AND ANSWERS

•

Body Types:	
Cab Pickup	353 to 356
Chassis and Cab	335 to 338
Custom Panel Delivery	340, 341
Station Wagon	348 to 352
Utility Coach	339
Utility Coupe	342 to 344
Utility Coupe with Pick-Up	345 to 347
Comfort and Convenience	334
Commercial Car Field	324
Instrument Panel Equipment	283, 284
Major Specifications	329
Rating	318 to 320
Safety Features	333
Strength Factors	330
Styling	322

