



2011 GMC SIERRA HEAVY DUTY (HD)

WHEN OUR ENGINEERS CREATED THE NEW 2011 SIERRA HEAVY DUTY SERIES, THEY LEFT NO BOLT UNTURNED. BY REJECTING COMPROMISE AND CRAFTING EVERY DETAIL, GMC DELIVERED THE STRONGEST, MOST POWERFUL AND MOST CAPABLE LINEUP OF SIERRA HD PICKUPS, EVER. FEATURING A COMPLETE SYSTEM OF CONTROL, CAPABILITY AND DRIVER COMFORT, THE NEW 2011 SIERRA HD AND THE FIRST-EVER DENALI HD REDEFINE HEAVY DUTY AND ARE THE PERFECT EXAMPLE OF WHY WE NEVER SAY NEVER.

GMC. WE ARE PROFESSIONAL GRADE.

A REDEFINING MOMENT.





SIERRA 2500HD CREW CAB SLT IN STORM GRAY METALLIC (L)
SIERRA 3500 DENALI HD WITH DUAL REAR WHEELS IN ONYX BLACK (R)
BOTH SHOWN WITH AVAILABLE EQUIPMENT

THE NEW HD FRAME

TAKE MORE. TOW MORE. HAUL MORE.

To help you get more in every load, and get more done every day, the new Sierra HD has the strongest frame we've ever built into an HD pickup. Crafted with high-strength alloy steel, and fully boxed from front to rear, it is engineered for a maximum Gross Combined Weight Rating (GCWR) of 29,200 lbs¹—the highest rating in its class.

FIGURE 1: HIGH STRENGTH, LOW WEIGHT

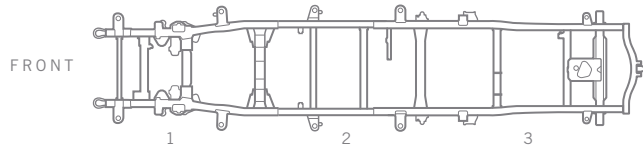

For the best strength-to-weight balance, the new Sierra HD frame is built up from three individual sections. This design made it possible to optimize each section for its task, from mounting the engine and transmission in the front section, to supporting the cab in the center section, to providing a solid platform for a segment-leading maximum payload and efficient fifth-wheel installation in the rear section. Together, these sections form a frame with almost twice the resistance to bending as the previous model.

FIGURE 2: A SOLID FOUNDATION FOR A SMOOTH RIDE



For maximum strength, the new Sierra HD frame features a hydroformed front frame section. This metal-forming process preserves uniform steel thickness throughout. To create the fully boxed frame rails, two C-channel sections are overlapped—essentially, welding a frame inside a frame—to form a box that resists sagging and bending.

¹When properly equipped; includes weight of the vehicle and trailer combination, including the weight of the driver, passengers, fuel, optional equipment and cargo in the vehicle and trailer. ²Maximum payload capacity includes weight of driver, passengers, optional equipment and cargo. ³Capacities and weight ratings are dependent upon model, engine, transmission and GVWR combinations. See your GMC dealer for details.

FIGURE 3: STRONGER MOUNTING, STRONGER FRAME

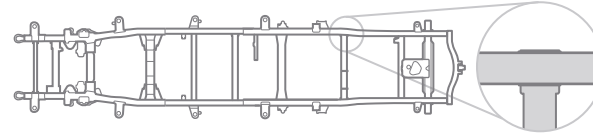

The sturdy boxed frame also allowed through-rail mounting for the tubular chassis cross-members. This mounting gives maximum support and resistance to twisting on uneven road surfaces.

FIGURE 4: A LOAD. NOT A BURDEN.



No other HD pickup offers more capacity in more models than Sierra. The 3500HD Regular Cab 2WD Dual-Rear-Wheel (DRW) model has maximum payload capacity of 6635 lbs². And GMC Sierra HD offers 2500- and 3500-Series capacity on Single-Rear-Wheel (SRW) models as well, with maximum payloads of 4192 lbs² on 2500 models, and 4632 lbs² on 3500 models.

FIGURE 5: READY TO PLOW

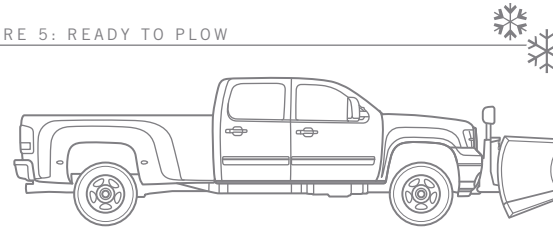

Adding a plow to Sierra HD is easy. Ask your dealer for the available Snow Plow Prep Package, and your truck will be prepared for most current hydraulic snow plows. It upgrades the front Gross Axle Weight Rating (GAWR) to 6000 lbs³ on diesel-equipped models, while the torsion-bar front suspension allows you to make seasonal ride-height adjustments in minutes, with a single wrench.





SIERRA 3500HD CREW CAB SLT WITH DUAL REAR WHEELS IN FIRE RED SHOWN WITH AVAILABLE EQUIPMENT

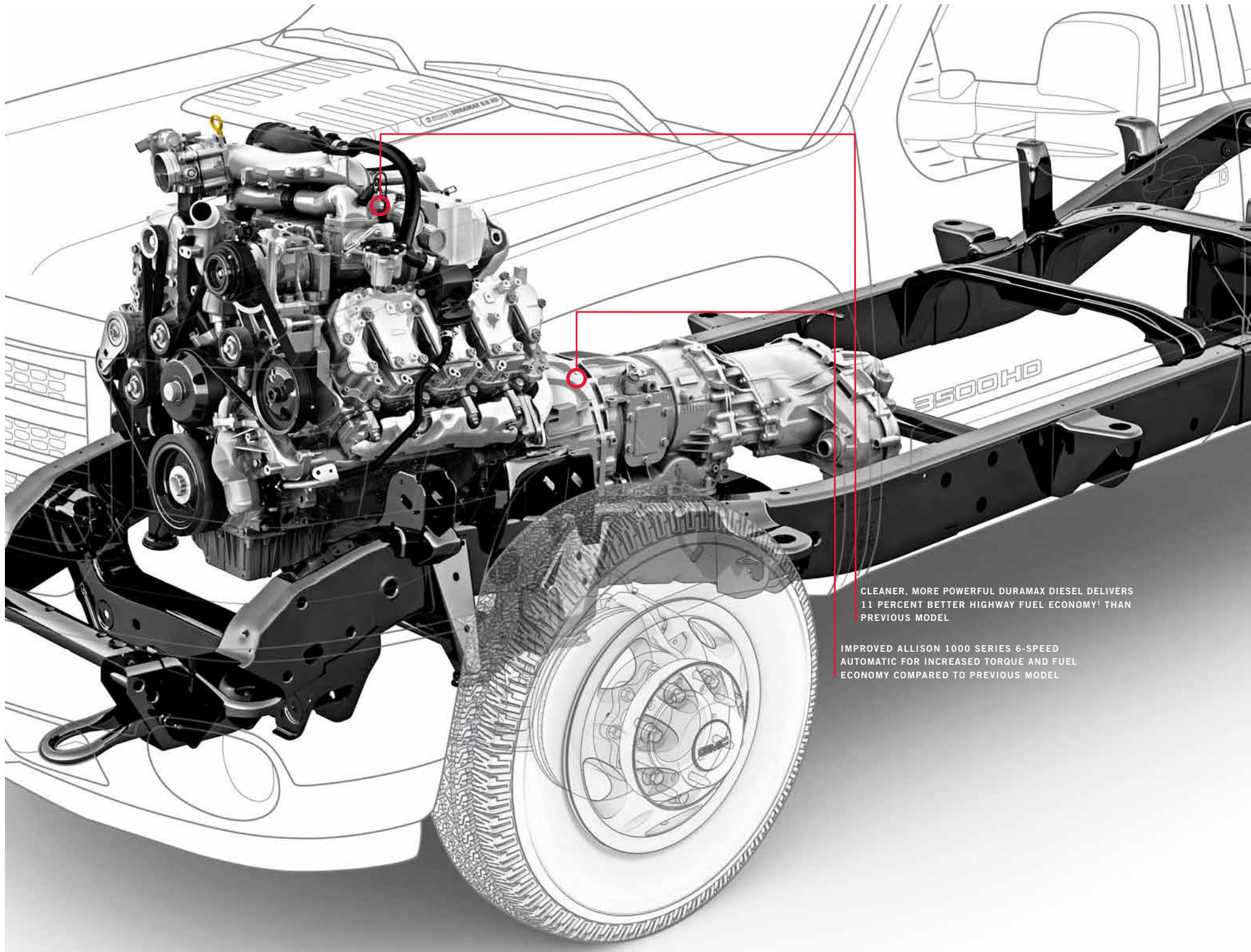

CLEANER, MORE POWERFUL DURAMAX DIESEL DELIVERS
11 PERCENT BETTER HIGHWAY FUEL ECONOMY* THAN
PREVIOUS MODEL

IMPROVED ALLISON 1000 SERIES 6-SPEED
AUTOMATIC FOR INCREASED TORQUE AND FUEL
ECONOMY COMPARED TO PREVIOUS MODEL

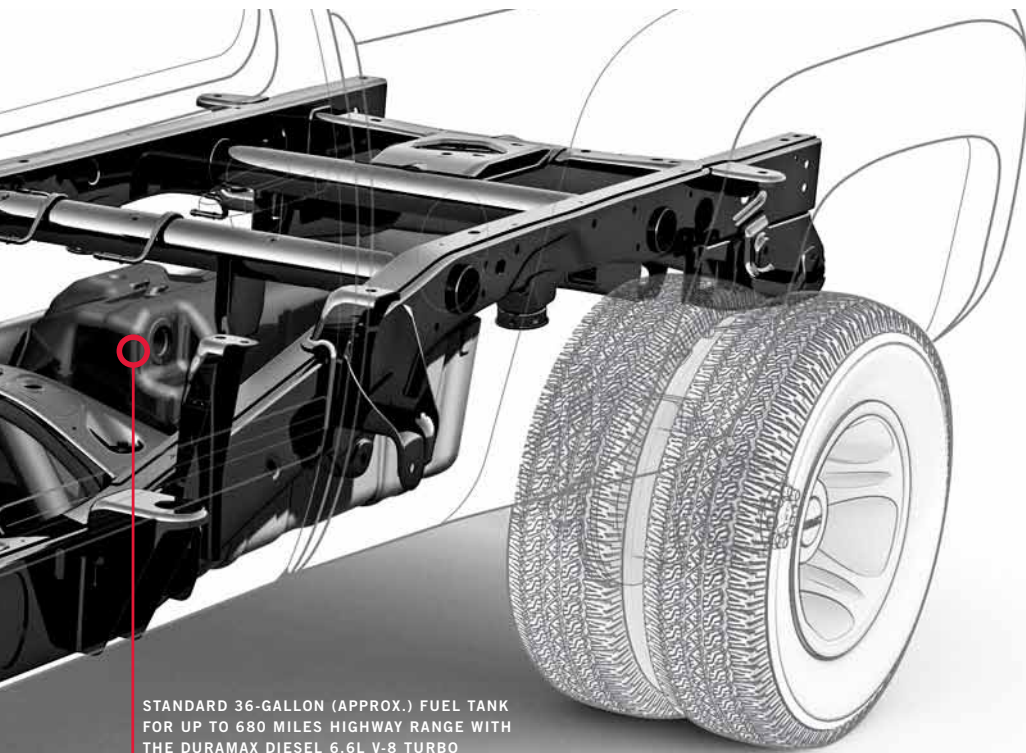

STANDARD 36-GALLON (APPROX.) FUEL TANK FOR UP TO 680 MILES HIGHWAY RANGE WITH THE DURAMAX DIESEL 6.6L V-8 TURBO

DURAMAX DIESEL 6.6L V-8 TURBO + ALLISON 1000 SERIES 6-SPEED AUTOMATIC

OFF-THE-CHART POWER. OFF-THE-MAP RANGE.

The available new Duramax Diesel 6.6L V-8 Turbo and Allison 1000 Series 6-speed automatic transmission are engineered to achieve a goal that most assumed to be impossible: improving power and mileage, together. Advanced diesel direct-injection technology and an adaptive transmission controller help Duramax to run at peak efficiency, and provide you with a highway mileage range of up to 680 highway miles.¹

PROVEN AND RELIABLE

The Duramax/Allison powertrain has a proven track record, with more than 1.2 million sold since 2000.

SMOOTH SHIFTS WITH EXCEPTIONAL CONTROL

The Allison 1000 Series 6-speed automatic—the same make used in the M1 tank—is built with multiple features to help the driver handle heavy loads with confidence. There's range selection mode to enhance control and engine braking in specific driving situations and grade braking mode that helps slow the vehicle on long grades by automatically selecting a lower gear.

FIGURE 7: IMPROVED FUEL ECONOMY



STARTS IN 3.0 SECONDS. AT -40° F.

A diesel that starts easily in Arctic-like weather? It's all in a cold day's work for the Duramax Diesel 6.6L V-8 Turbo. With an advanced Direct-Injection (DI) fuel system, the Duramax injectors pressurize fuel up to 30,000 psi. That helps to turn cold, heavy diesel fuel into an ultra-fine mist that burns quickly and easily, to give you fast starts, quieter operation and lower emissions than the previous model.

B20 BIODIESEL FUEL COMPATIBLE

To help reduce carbon dioxide emissions, the Duramax Diesel 6.6L V-8 Turbo can run on B20 biodiesel, a mixture of 20 percent biodiesel produced from domestic renewable resources, and 80 percent petroleum diesel.

¹Based on GM testing. ²Visit onstar.com for details and system limitations.

A MONTHLY CHECKUP FROM ONSTAR

With available OnStar, your Sierra HD can run through a monthly check of your engine, transmission, antilock brakes and more and e-mail you the results.² You can also ask for an OnStar Onboard Vehicle Diagnostics check while you're driving.

FIGURE 6: 2011 DURAMAX DIESEL 6.6L V-8 TURBO

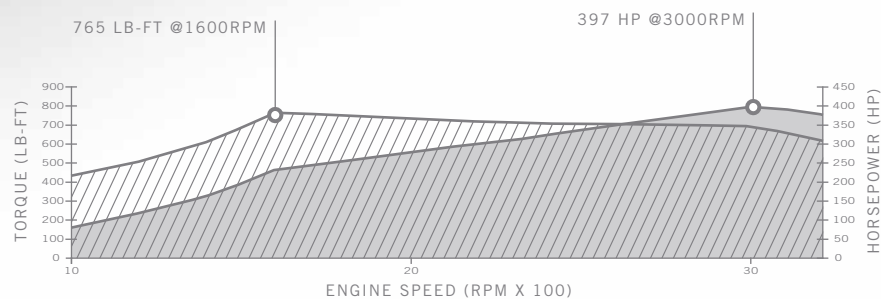

6.0L VORTEC VVT V-8 + HYDRAMATIC 6L90-E

ABSOLUTE POWER IS ABSOLUTELY NECESSARY.

How you apply power is just as important as how much power you have. So, the standard 6.0L Vortec VVT V-8 delivers torque and horsepower across a wide RPM range. Matched with the Hydramatic 6L90-E, it gives the driver smooth and progressive response for effortless driving, trailering or hauling.

IMPROVED LOW-SPEED RESPONSE

The 6.0L Vortec VVT V-8 has a revised camshaft profile that gives you a deep reserve of low-end torque. It's most helpful in driving situations where you need to apply power gently and progressively, such as trailering heavy objects, backing up to attach a trailer or maneuvering in tight spaces.

ALL POWER AND NO COMPROMISE

Variable Valve Timing (VVT) changes when and how intake and exhaust valves open and close. This changes engine performance from a smooth and quiet-idling dynamo to a bold, aggressive, high-performance V-8 at full throttle. This helps to provide you with ample reserve power at virtually every speed, so you can approach challenging trailering or load-carrying situations with confidence.

FIGURE 8: 6.0L VORTEC VVT V-8 HORSEPOWER AND TORQUE

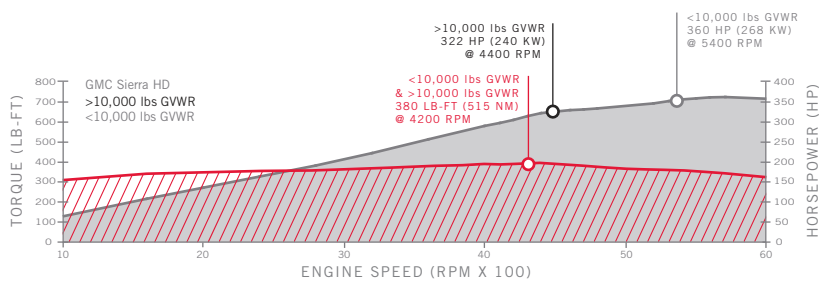

SMOOTHER SHIFTS AUTOMATICALLY

The ideal partner to the 6.0L Vortec VVT V-8, the advanced Hydramatic 6L90-E 6-speed transmission constantly senses load, acceleration and other inputs, then controls engine torque for smooth, almost imperceptible shifts.





SIERRA 2500HD CREW CAB SLT IN PURE SILVER METALLIC SHOWN WITH AVAILABLE EQUIPMENT

NEW HEAVY-DUTY SUSPENSION

THE STORY BEGINS AT THE END OF THE ROAD.

The best way to appreciate the engineering that went into the new Sierra HD suspension is when the road is at its worst, or when there is no road at all. With a redesigned fully independent torsion-bar front suspension on every model, and a completely revised rear suspension, Sierra HD removes the compromise between ride comfort and load capacity, so you can trailer or haul heavy loads with a comfortable margin of control.

INDEPENDENT FRONT SUSPENSION

All Sierra HD models have a new Independent Front Suspension (IFS), designed for the constant punishment of heavy-duty use. Built extra-strong from extreme-duty components, it gives both a smoother ride than conventional beam-axle suspensions and up to a 6000 lb front axle GAWR¹ that is unsurpassed by competitive HD models.

FIGURE 9: REAR LEAF SPRINGS THAT MATCH THE LOAD

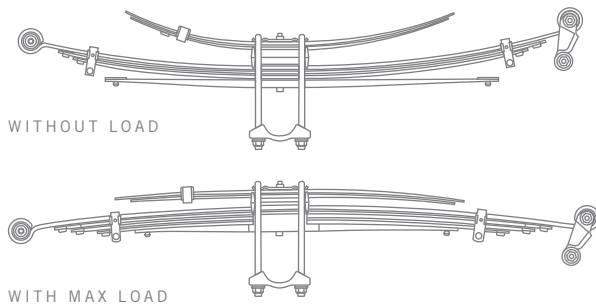

The more load your HD takes, the more its springs step up to the challenge. New rear leaf springs are 3 inches wide—two-stage for 2500 models, and three-stage for 3500 models.

¹Capacities and weight ratings are dependent upon model, engine, transmission and GVWR combinations. See your GMC dealer for details.

FIGURE 10: BODY MOUNTS THAT TUNE OUT VIBRATION

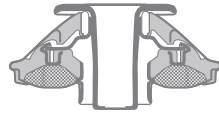

Vibrations are the enemy of comfort. That's why Sierra HD Extended and Crew Cab models are cushioned at the rear cab frame attachments with hydraulic body mounts.

FIGURE 11: TRACTION THAT'S FULLY AUTOMATIC

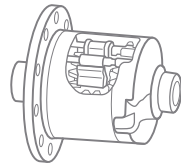

No other competitor in the class offers an available fully automatic locking rear differential, for on- or off-road use. When the Eaton® Locker senses a difference in wheel speed between left and right rear wheels of approximately 100 rpm, it locks both rear wheels to turn in unison for added traction.





SIERRA 2500HD CREW CAB SLT IN PURE SILVER METALLIC SHOWN WITH AVAILABLE EQUIPMENT

NEW HD TRAILERING CAPABILITY

ONE CASE WHERE MORE WEIGHT IS A GOOD THING.

The new Sierra HD is built with the power and capacity to give you significantly improved trailering capability. Virtually every aspect was rethought or reinforced for heavy loads and high Gross Vehicle Weight Ratings (GVWRs). More important is the sense of control that comes from knowing GMC has already anticipated your task and built accordingly.

FIGURE 12: EXCEPTIONAL MAX PAYLOAD AND TRAILERING

We said HD, and we mean it. Sierra HD offers outstanding payload and trailering, including segment-leading conventional trailering capability of up to 17,000 lbs,¹ and fifth-wheel trailering capability of up to 21,700 lbs²

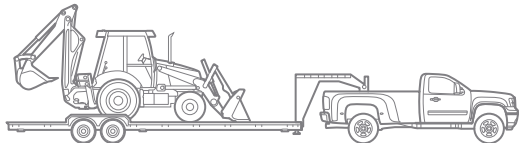

3500HD 4WD REG. CAB, DURAMAX 21,700 LBS (MAX) TRAILERING CAPACITY

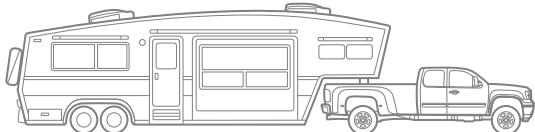

3500HD 2WD EXT. CAB, DURAMAX 21,500 LBS (MAX) TRAILERING CAPACITY

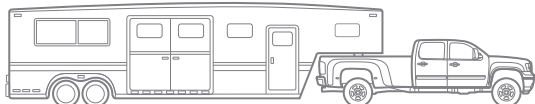

3500HD 2WD CREW CAB, DURAMAX 21,500 LBS (MAX) TRAILERING CAPACITY

BUILT-IN FIFTH-WHEEL PREP

To help you choose the fifth-wheel or gooseneck hitch that works best for your needs, our engineers consulted with leading aftermarket hitch manufacturers. Based on their input, we added new access holes to the rear frame section to accept a wider variety of hitches. These holes also help to preserve frame strength and save installation time.

¹Maximum trailer weight ratings are calculated assuming a base vehicle, except for any option(s) necessary to achieve the rating, plus driver. The weight of other optional equipment, passengers and cargo will reduce the maximum trailer weight your vehicle can tow. See your GMC dealer for additional details.

FIGURE 13: KEEPING YOUR TRAILER IN LINE

Standard on all Sierra HD SRW models, Sierra HD trailer sway control uses the built-in StabiliTrak sensors to look for changes in ride motion that could indicate trailer sway, and then applies braking as needed to bring the trailer back in line.

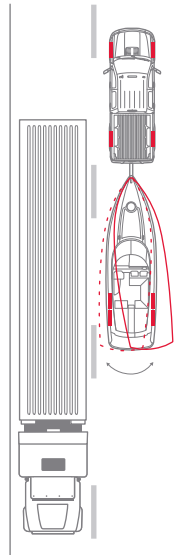

A fully integrated trailer brake controller is also available to give you greater control of trailer braking force.

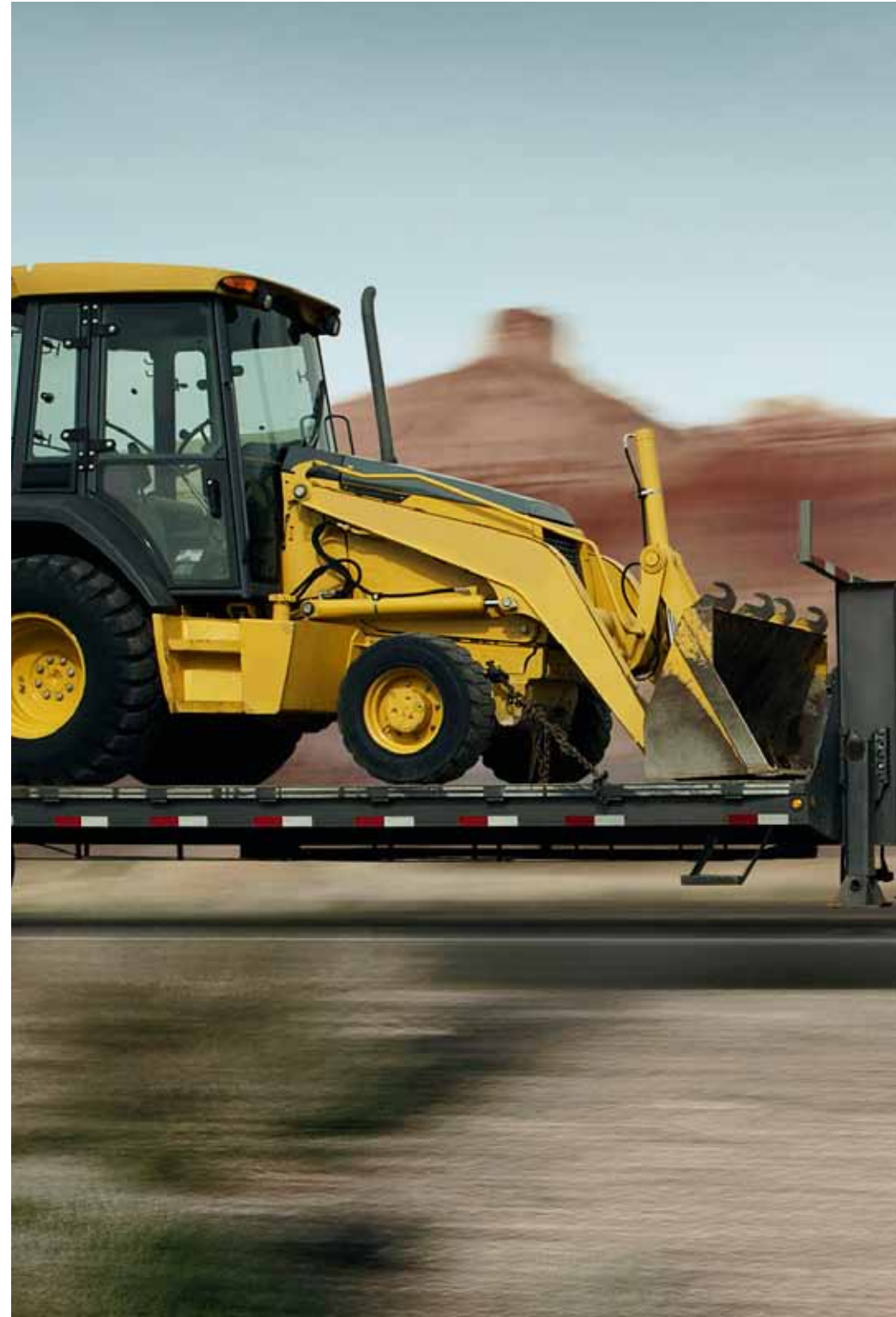



SIERRA 3500HD CREW CAB SLT WITH DUAL REAR WHEELS IN FIRE RED SHOWN WITH AVAILABLE EQUIPMENT



SIERRA 2500HD CREW CAB SLE IN STORM GRAY METALLIC SHOWN WITH AVAILABLE EQUIPMENT



NEW HD BRAKING SYSTEM

BRAKING POWER THAT GOES BEYOND THE PEDAL.

Sierra HD's braking system is much more than a pedal. It is a system of control engineered to help keep you on your intended path, and maintain your cool no matter how challenging the situation. Because, with a heavy load behind you, you need to be ready for what's ahead of you.

FIGURE 14: HEAVY-DUTY CONTROL

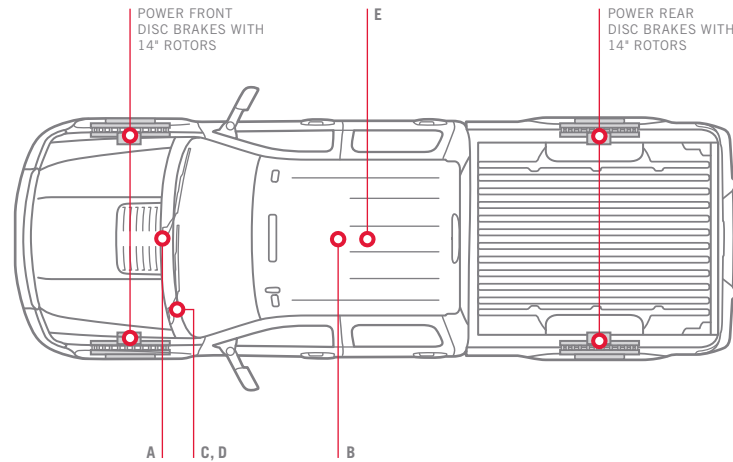

A: "SMART" BRAKING POWER

The new diesel exhaust brake is an innovative standard feature for Duramax models. Unlike the traditional "on/off" diesel exhaust brakes, the driver-selectable "smart" brake varies negative torque needed, based on the truck load and grade. This helps reduce brake fade, extends brake life and gives drivers plenty of confidence when hauling heavy loads downhill.

B: EXTRA CONFIDENCE ON LONG GRADES

Automatic Grade Braking monitors vehicle speed, acceleration, engine torque and brake pedal usage. Using this information, it detects when the truck is on a downhill grade and the driver desires to slow the vehicle. Then if necessary, the transmission downshifts to help hold the desired speed.

C: FASTER STOPS, AUTOMATICALLY

To get full braking force as fast as possible in urgent stops, all Sierra HD SRW models feature Intelligent Brake Assist. If the system senses rapid brake-pedal movement, it automatically applies full system pressure, which can shorten stopping distances.

D: HILL START BRAKE ASSIST

This standard feature senses potential "roll-back" when braking on an incline, and then holds full brake pressure when you lift your foot from the pedal. It gives you an extra 1½ seconds to apply power and pull away. This peace of mind is standard on Sierra HD SRW models.

E: STABILITRAK

Standard on Sierra HD SRW models, StabiliTrak senses when your vehicle is not adequately responding to your steering inputs, then adjusts engine speed and brake pressure to any individual wheel to help maintain traction and steering control.





SIERRA 2500 DENALI HD CREW CAB IN ONYX BLACK SHOWN WITH AVAILABLE EQUIPMENT

SIERRA DENALI HD INTERIOR DETAILS

THE UTMOST IN EXCLUSIVITY. THE ULTIMATE IN CAPABILITY.

From leather-appointed seating surfaces to the polished wood tones and brushed metal accents, the first-ever Denali gives the Sierra HD series a new and even more refined meaning. With its extensive list of standard features, Denali HD gives you the luxury of the boardroom with the power to match.

REFINED ACOUSTICS

Sierra Denali HD is engineered to minimize noise and vibration for a quiet, refined atmosphere. These advanced acoustics also help you to enjoy the Bose® Centerpoint® Sound System. It delivers five independent channels from stereo recordings to give you a surround listening experience from your existing music library. SurroundStage® processing lets the driver and occupants feel as if they are center stage, while AudioPilot® compensates for changing ambient noise levels.

COMFORT IN ANY WEATHER

Denali HD's 12-way power seats are available with their own climate control system. They warm you with built-in heating elements, or cool you with air that flows through the perforated leather seat inserts. A heated steering wheel, exclusive to Denali, is a welcome option in cold climates.

DVD-BASED TOUCH-SCREEN NAVIGATION

The available DVD-based touch-screen navigation system³ combines superb audio performance with mapping capabilities from a variety of sources. It features a 6.5-inch display, 2-D or 3-D graphics and 3 months of XM NavTraffic.⁴ It also integrates with OnStar Turn-By-Turn Navigation⁵ so you will never stop to ask directions.



A six-month subscription to OnStar⁵ that includes OnStar Directions & Connections is standard in Denali, SLT and SLE models. With Turn-By-Turn Navigation, you just push the OnStar button to tell the Advisor where you want to go, and turn-by-turn directions are downloaded to your vehicle. OnStar eNav lets you plan routes on mapquest.com and store them in your vehicle so you can call them up with a simple voice command. OnStar Destination Download lets you contact your Advisor and then download directions to your screen-based navigation system.

BLUETOOTH® CONNECTIVITY

To help you stay in touch at all times, Bluetooth¹ capability is standard in Denali and SLT models to let you connect your wireless phone or PDA to the standard hands-free calling system.

This allows you to control your device with the phone and audio system controls located on the steering wheel.

STAY CONNECTED WITH AUTONET WIFI

Make your Sierra HD a wireless hot spot with available dealer-installed Autonet Mobile WiFi;² the first wireless Internet service provider designed for automotive use. It allows up to 10 people to connect to the Internet at once, using any combination of smart phones, laptops, or WiFi-enabled devices. Ask your dealer for plan prices and details.

¹Go to gm.com/bluetooth to find out which Bluetooth phones are compatible with the vehicle. ²Monthly rates apply. Visit autonetmobile.com for coverage map and details. ³Not available in Puerto Rico or the Virgin Islands. Hawaii vehicles have state of Hawaii functionality only. ⁴XM NavTraffic and XM Radio require subscriptions, sold separately after the first 90 days. XM Radio U.S. service only available in the 48 contiguous United States and the District of Columbia. For more information, visit gm.xmradio.com. ⁵Visit onstar.com for coverage map, details and system limitations.





SIERRA DENALI HD IN EBONY SHOWN WITH AVAILABLE EQUIPMENT



SIERRA 2500HD CREW CAB SLT IN LIGHT TITANIUM SHOWN WITH AVAILABLE EQUIPMENT



SLT INTERIOR DETAILS

THE SUITE LIFE.

Control. Comfort. Capacity. That's the story of Sierra SLT HD. Beyond the crisp details, precise fits and premium materials, SLT also offers comprehensive security and entertainment technology. It all works together to give you the advantage, whatever the situation.

ONSTAR AUTOMATIC CRASH RESPONSE

You can get help even if you can't ask for it. In the event of a crash, built-in sensors can automatically send an alert to OnStar.¹ An Advisor is immediately connected into your vehicle to see if you need help. Even if you can't respond, the Advisor can use GPS technology to send emergency responders to your exact location. Visit onstar.com to learn more.

AIR BAG RESTRAINT SYSTEMS²

In addition to frontal air bags, head curtain side-impact air bags and seat-mounted side-impact pelvic and thorax air bags are available on all 2500 HD models.

REAR-SEAT ENTERTAINMENT (RSE)

Available on Denali and SLT Crew Cab models, RSE includes a DVD player and an 8-inch diagonal flip-down screen. It also comes with dual play, which has a separate upper DVD slot in the stereo to help front-seat passengers to control the DVD or music playing behind them. RSE is compatible with most popular video gaming systems. The RSE also includes a wireless infrared remote control and two sets of wireless headphones.

BOSE PREMIUM SOUND SYSTEM

For the ultimate in sound quality and listening convenience, the Sierra SLT audio system includes features such as steering-wheel-mounted radio controls and a Bose premium speaker system with a subwoofer mounted in the center console for deep, low-frequency response.



¹OnStar acts as a link to existing emergency service providers. Visit onstar.com for details and system limitations. ²Air bag inflation can cause severe injury or death to anyone too close to the bag when it deploys. Be sure every occupant is properly restrained. Always use safety belts and the correct restraint for your child's age and size. Children are safer when properly secured in a rear seat in the appropriate infant, child or booster seat. Never place a rear-facing infant restraint in the front seat of any vehicle equipped with a passenger air bag. See the Owner's Manual and child safety seat instructions for more safety information.





SIERRA 3500HD DRW CREW CAB SLT IN PURE SILVER METALLIC (L)
SIERRA 2500HD CREW CAB SLT IN STORM GRAY METALLIC (C)
SIERRA 2500 DENALI HD IN ONYX BLACK (R)
VEHICLES SHOWN WITH AVAILABLE EQUIPMENT

STANDARD AND AVAILABLE FEATURES/SIERRA 2500HD/3500HD/DENALI HD

TRIM LEVELS	WT	SLE	SLT	DENALI
CONFIGURATIONS				
REGULAR CAB	•	•	—	—
EXTENDED CAB	•	•	•	—
CREW CAB	•	•	•	•
MECHANICAL				
ENGINES				
6.0L Vortec V-8 with Sequential Fuel Injection (SFI)	S	S	S	S
Duramax Diesel 6.6L V-8 Turbo with direct injection and B20 biodiesel capability	A	A	A	A
TRANSMISSIONS				
GM Hydramatic 6L90-E 6-speed automatic. Standard and only available with 6.0L Vortec V-8.	S	S	S	S
Allison 1000 Series 6-speed automatic. Included and only available with Duramax Diesel 6.6L V-8 Turbo.	A	A	A	A
ALTERNATOR				
125-amp	S	S	S	S
160-amp. Included with Snow Plow Prep Package when Vortec 6.0L SFI V-8 is ordered. Requires Vortec 6.0L SFI V-8.	A	A	A	A
Dual, 125 amps each. Included with Snow Plow Prep Package when Duramax Diesel 6.6L V-8 Turbo is ordered. Requires Duramax Diesel 6.6L V-8 Turbo engine.	A	A	A	A
BATTERY				
Heavy-duty, maintenance-free with 600 cold-cranking amps, rundown protection and retained accessory power	S	S	S	S
Auxiliary heavy-duty, maintenance-free with 600 cold-cranking amps. Not available with Duramax Diesel 6.6L V-8 Turbo engine.	A	A	A	A
Heavy-duty, two batteries, maintenance-free with 730 cold-cranking amps, with rundown protection and retained accessory power. Included and only available with Duramax Diesel 6.6L V-8 Turbo engine.	A	A	A	A
BRAKES 4-wheel antilock, 4-wheel disc	S	S	S	S
EATON HEAVY-DUTY AUTOMATIC LOCKING REAR DIFFERENTIAL Included with (Z82) trailering equipment. Standard on 3500 2WD Regular Cab models. Standard on 3500 SRW models.	A	A	S	S
ENGINE BLOCK HEATER	A	A	A	A
ENGINE OIL COOLER Heavy-duty external air-to-oil. Integral to driver side of radiator tank.	S	S	S	S
EXHAUST Aluminized stainless steel	S	S	S	S

TRIM LEVELS	WT	SLE	SLT	DENALI
EXHAUST BRAKE With available Duramax Diesel 6.6L V-8 Turbo engine only	S	S	S	S
FRAME Fully boxed with hydroformed front section	S	S	S	S
HIGH-CAPACITY AIR CLEANER	S	S	S	S
HIGH IDLE SWITCH On WT models, requires cruise control	A	A	A	A
RADIATOR GRILLE AND FRONT BUMPER OPENINGS COVER For cold weather. Requires Duramax Diesel 6.6L V-8 Turbo.	A	A	A	A
REAR AXLE				
3.73 ratio	S	S	S	S
4.10 ratio. Requires Vortec 6.0L V-8 engine.	A	A	A	A
SKID PLATE PACKAGE Frame-mounted shields, includes front underbody shield starting behind front bumper and running to first cross-member, protecting front underbody, oil pan, differential case and transfer case	A	A	A	S
SNOW PLOW PREP PACKAGE Includes 10-amp power for back-up and roof emergency light, 160-amp alternator (dual 125 amp included with Diesel), high-flow front bumper, forward lamp wiring harness, provision for cab roof-mounted lamp/beacon, instrument panel jumper wiring harness for electric trailer brake controller, high-capacity air cleaner, auxiliary external transmission oil cooler and Skid Plate Package (4WD models only)	A	A	A	A
STABILITRAK Stability control system. Includes electronic trailer sway control, Intelligent Brake Assist and hill start brake assist (SRW models only).	S	S	S	S
STEERING Power, recirculating ball	S	S	S	S
SUSPENSION				
Front independent with torsion bar with increased front GAWR	S	S	S	S
Rear multi-leaf springs, semi-elliptic with urethane jounce bumpers	S	S	S	S
Heavy-Duty Handling/Trailering Suspension Package Z71 Off-Road Suspension Package. Includes off-road jounce bumpers, Skid Plate Package and Z71 decals on rear quarters.	S	S	S	S
TRAILERING	—	A	A	A
Heavy-Duty Trailering Package. Includes trailering hitch platform and 2.5" receiver with 2" adapter, 7-wire harness with independent fused trailering circuits mated to a 7-way sealed connector, wiring harness for aftermarket trailer brake controller (located in the instrument panel harness) and available integrated trailer brake controller.	A	A	S	S
Integrated trailer brake controller	A	A	S	S

TRIM LEVELS	WT	SLE	SLT	DENALI
Trailering wiring provisions for camper, fifth-wheel and gooseneck trailers; includes additional 8-way wiring harness routed to front of pickup box. Requires Heavy-Duty Trailering Package.	A	A	A	A
TRANSFER CASE				
With floor-mounted shifter (4WD models)	S	—	—	—
Electronic shift with rotary dial controls (4WD models)	—	S	S	S
TRANSMISSION OIL COOLER Auxiliary external heavy-duty air-to-oil	S	S	S	S
SEATING				
SEATS				
40/20/40 front split-bench with driver and front-passenger manual recline and center fold-down armrest with storage	S	—	—	—
40/20/40 front split-bench with driver and front-passenger manual recline, center fold-down armrest and lockable storage compartment in seat cushion (includes auxiliary power outlet). Adjustable outboard head restraints and storage pockets on Extended and Crew Cab models.	—	S	—	—
Front buckets with 6-way power seat adjusters, manual recline, manual lumbar and adjustable head restraints. Requires Extended or Crew Cab models.	—	A	—	—
Front buckets with 10-way power seat adjusters (SLT) or 12-way (Denali) including 2-way power lumbar control, heated seat cushions and seatbacks, 2-position driver memory (does not apply to lumbar adjuster on SLT) and adjustable head restraints. Includes floor console and storage pockets.	—	—	S	S
Heated and cooled seats for driver and front passenger. Includes 12-way power seat adjusters and perforated leather seating surfaces.	—	—	—	A
Driver-side manual seat adjuster with lumbar control. On WT models, included and only available with Dark Titanium cloth seat trim.	A	S	—	—
Folding rear bench, full width. Extended Cab models only.	S	—	—	—
60/40 folding rear bench. WT requires Crew Cab models. SLE requires Extended or Crew Cab models.	S	S	S	S
SEAT TRIM				
Dark Titanium vinyl with Graphite-colored rubberized vinyl floor covering	S	—	—	—
Dark Titanium cloth	A	—	—	—
Premium cloth	—	S	—	—
Front leather-appointed seating. Includes 6-way power driver seat adjuster. Not available on Regular Cab models.	—	A	S	—
Front leather-appointed seating, Nuance	—	—	—	S

A-Available S-Standard — -Not Available P-Package
See dealer for availability, inclusions and exclusions.

SRW-Single Rear Wheel DRW-Dual Rear Wheel

TRIM LEVELS	WT	SLE	SLT	DENALI
INSTRUMENTATION AND CONTROLS				
CRUISE CONTROL	P	S	S	S
INSTRUMENTATION				
Analog cluster with speedometer, fuel level, engine temperature and tachometer; includes voltmeter and oil pressure indicators	S	S	S	S
Driver Information Center with odometer, trip odometer and message center. On SLE, SLT and Denali models, includes compass and outside temperature.	S	S	S	S
POWER-ADJUSTABLE PEDALS	—	P	P	S
REARVIEW CAMERA SYSTEM With inside rearview mirror display; if Touch-Screen Navigation is ordered, camera display is on NAV screen	—	P	P	A
STEERING WHEEL				
Tilt-Wheel adjustable steering column with brake/transmission shift interlock	S	S	S	S
Leather-wrapped (color-keyed on Denali). On WT models, requires Bluetooth®	A	S	S	S
Heated, leather-wrapped and color-keyed	—	—	—	A
Steering-wheel-mounted audio controls. On WT, requires Bluetooth.	A	P	S	S
ULTRASONIC REAR PARKING ASSIST With audible warning. Requires Extended or Crew Cab models.	—	P	P	S
INTERIOR DETAILS AND CONVENIENCE FEATURES				
CARPETING				
Color-keyed with rubberized vinyl floor mats. Extended and Crew Cab models also include rear floor mats; WT models require Dark Titanium cloth seat trim.	A	S	S	—
Color-keyed with removable carpeted floor mats for first and second row	—	—	—	S
CLIMATE CONTROL				
Single-zone manual air conditioning	S	S	—	—
Dual-zone automatic air conditioning with individual settings for driver and right-front passenger; not available with Regular Cab models	—	P	S	S
DEFOGGER Rear window. Not available with power-sliding rear window.	A	A	S	S
FLOOR COVERING Black rubberized vinyl	S	A	—	—
POWER DOOR LOCKS With remote keyless entry (2 transmitters, panic button and content theft alarm). Standard on WT Crew Cab models. Included with Work Truck Preferred Package.	A	S	S	S
REARVIEW MIRROR				
With manual day/night adjustment	S	S	—	—

Auto-dimming	—	P	S	S
REMOTE START With remote keyless entry. Remote keyless entry does not lock/unlock tailgate.	—	P	S	S
SUNROOF Power with express-open. Includes Universal Home Remote.	—	—	A	A
UNIVERSAL HOME REMOTE	—	P	P	S
WINDOWS				
Power with driver express-down. SLT and Denali models include front passenger express-down.	—	S	S	S
Rear-access-door, power. Requires Extended Cab models.	—	S	S	—
Rear, power-sliding. Not available with Regular Cab models or with rear-window defogger.	—	A	A	A

OPTION PACKAGES

WORK TRUCK PREFERRED PACKAGE Includes cruise control, Solar-Ray deep-tinted glass, fog lamps and 17" chrome-clad steel wheels (2500 model only). On Regular and Extended Cab models, includes power door locks and Remote Keyless Entry.	A	—	—	—
SLE PREFERRED PACKAGE REGULAR CAB Includes remote vehicle starter system, steering-wheel-mounted controls, CD player, Bluetooth ¹ for your cell phone, fog lamps and EZ-Lift locking tailgate	—	A	—	—
SLE PREFERRED PACKAGE EXTENDED OR CREW CAB Includes steering-wheel-mounted controls, dual-zone automatic air conditioning, 6-way power driver seat adjuster, CD player, Bluetooth ¹ for your cell phone, fog lamps and EZ-Lift locking tailgate	—	A	—	—
SLE CONVENIENCE PACKAGE Includes power-adjustable pedals, Universal Home Remote, remote vehicle starter system, rear-window defogger and Ultrasonic Rear Parking Assist	—	A	—	—
SLT CONVENIENCE PACKAGE Includes Universal Home Remote, power-adjustable pedals, EZ-Lift locking tailgate, Ultrasonic Rear Parking Assist and rear-wheel house liners (dealer installed)	—	—	A	—

ENTERTAINMENT/COMMUNICATION/NAVIGATION

AM/FM STEREO				
4-speaker system (Regular Cab)	S	—	—	—
6-speaker system (Extended/Crew Cab)	S	S	S	—
Seek-and-scan and digital clock	S	S	S	S
With MP3-compatible CD player	A	S	—	—
With CD player, MP3 playback and USB port ²	A	P	S	—
On SLE models, requires SLE Preferred Package.				
With MP3-compatible 6-disc in-dash CD changer and USB port ²	—	A	A	S

TRIM LEVELS	WT	SLE	SLT	DENALI
With MP3-compatible CD/DVD player and USB port. ² On SLT, requires Crew Cab models. On Denali models, requires Rear-Seat Entertainment Package.	—	—	A	A
BLUETOOTH FOR PHONE¹ Personal cell-phone connectivity to vehicle audio system allowing hands-free calling	A	P	S	S
BOSE® AUDIO				
Premium speaker system with subwoofer. On SLE models, requires front bucket seats.	—	A	S	S
Centerpoint® Surround Sound System	—	—	—	S
ONSTAR³ Directions & Connections plan. Six-month subscription. See page 29 for details.	A	S	S	S
REAR-SEAT ENTERTAINMENT PACKAGE Rear-seat DVD player with LCD display and 2 sets of wireless headphones. Includes rear audio controls. Requires Crew Cab models. On SLT models, includes AM/FM stereo with MP3-compatible CD/DVD player. On Denali models, requires CD/DVD player.	—	—	A	A
TOUCH-SCREEN NAVIGATION⁴ AM/FM stereo with MP3-compatible CD player and DVD-based navigation with voice prompts and USB port. ² includes Bose premium speaker system and 3 trial months of XM Radio ⁵ with XM NavTraffic. ⁶ On SLE models, requires front bucket seats.	—	A	A	A
TOUCH-SCREEN NAVIGATION⁴ WITH REAR-SEAT ENTERTAINMENT PACKAGE AM/FM stereo with MP3-compatible CD/DVD player, DVD-based navigation and USB port. ² Includes 3 trial months of XM Radio ⁵ with XM NavTraffic. ⁶ Requires Crew Cab models.	—	—	A	A
XM NAVTRAFFIC⁶ Including 3 trial months of service and only available with Touch-Screen Navigation. See page 29 for details.	—	A	A	A
XM RADIO⁵ Including 3 trial months of service. See page 29 for details.	A	S	S	S

SIERRA AVAILABLE FEATURES

REAR-SEAT ENTERTAINMENT SYSTEM
An 8" diagonal LCD screen drops down from the headliner behind the front row. Audio is through wireless headphones or speaker system.



TOUCH-SCREEN NAVIGATION⁴
Select either 2-D or 3-D map views of your route, and listen to verbal directions in your choice of English, Spanish or French.

¹Go to gm.com/bluetooth to find out which Bluetooth phones are compatible with the vehicle. ²Not compatible with all devices. ³Visit onstar.com or call 1-888-4ONSTAR (466-7827) for details and system limitations. ⁴Not available in Puerto Rico or the Virgin Islands. Hawaii vehicles have state of Hawaii functionality only. ⁵XM Radio requires a subscription, sold separately by XM after the first 90 days. XM Radio U.S. service only available in the 48 contiguous United States and the District of Columbia. For more information, visit gm.xmradio.com. ⁶Required XM Radio and NavTraffic monthly subscriptions sold separately by XM after trial period. XM NavTraffic only available in select markets. For more information, visit xmradio.com/navtraffic.

TRIM LEVELS	WT	SLE	SLT	DENALI
-------------	----	-----	-----	--------

EXTERIOR STYLING AND FUNCTIONALITY

BODYSIDE MOLDINGS Body-color. Chrome insert on Denali models.	—	S	S	S
BUMPERS Front, chrome. On WT models, includes black bumper top caps. On SLE and SLT models, includes body-color bumper top caps. Front, body-color Rear, chrome step-style with pad Rear, body-color step-style with pad	S	S	S	—
DOOR HANDLES Black Body color Chrome	S	S	—	—
EZ-LIFT LOCKING TAILGATE Includes tailgate lock	—	P	P	S
GLASS Solar-Ray deep tinted	A	S	S	S
GRILLE SURROUND Chrome. Includes chrome center with integrated lower grille surround on Denali models.	S	S	S	S
LICENSE PLATE BRACKET Front included in all states that require a front license plate	A	A	A	A
LIGHTS Halogen front fog lamps Dual cargo area lamps	P	P	S	S
RECOVERY HOOKS Front, frame-mounted	S	S	S	S
TIRE CARRIER Outside spare, winch-type mounted under frame	S	S	S	S
WIPERS Wet-arm front intermittent	S	S	S	S

OUTSIDE MIRRORS

Manual-folding, black (2500/3500 models)	S	—	—	—
Heated power-adjustable, manual-folding, black. Standard on 2500 models only.	—	S	—	—
Heated power-adjustable/power-folding. With integrated turn signal indicators and driver-side auto-dimming; body-color. Includes curb tilt. Standard on 2500 models only.	—	—	S	S

VERTICAL CAMPER

Manual-folding with lower convex spotter glass. See dealer for availability.	A	—	—	—
Heated, power-adjustable with integrated turn signal indicators; manual-folding/extension; black (convex glass is not heated or power adjustable). Standard on 3500 SLE, SLT and Denali models. Available on 2500 models.	—	A	A	A

SAFETY

AIR BAGS¹ Frontal. Standard with front driver and passenger single-stage air bag. Head curtain side-impact, front outboard seating positions with rollover sensor (2500 models only) Seat-mounted, side-impact driver and right front passenger, for thorax and pelvic protection (2500 models only)	S	S	S	S
DAYTIME RUNNING LAMPS With automatic lamp control	S	S	S	S
TIRE PRESSURE MONITORING SYSTEM (Does not monitor spare tire.) Not available on 3500HD DRW.	S	S	S	S

FRONT GROSS AXLE WEIGHT RATING (FGAWR) WITH VYU SNOW PLOW PREP PACKAGE (4WD MODELS ONLY)

BODY	ENGINE RPO	ENGINE TYPE	2500	3500 SRW	3500 DRW
Regular Cab	L96	Gas	5200	5600	5600
	LML	Diesel	6000	6000	6000
Extended Cab Standard Box	L96	Gas	5200	—	—
	LML	Diesel	6000	—	—
Extended Cab Long Box	L96	Gas	5600	5600	5600
	LML	Diesel	6000	6000	6000
Crew Cab Standard Box (includes Denali)	L96	Gas	5200	5600	—
	LML	Diesel	6000	6000	—
Crew Cab Long Box (includes Denali)	L96	Gas	5600	5600	5600
	LML	Diesel	6000	6000	6000

MAXIMUM PLOW WEIGHTS (4WD MODELS ONLY)

BODY	ENGINE RPO	ENGINE TYPE	2500	3500 SRW	3500 DRW
Regular Cab	L96	Gas	100/925	100/1000	100/1000
	LML	Diesel	100/1000	100/975	100/875
Extended Cab Standard Box	L96	Gas	100/875	—	—
	LML	Diesel	100/925	—	—
Extended Cab Long Box	L96	Gas	100/1000	100/1000	100/950
	LML	Diesel	100/875	100/825	100/725
Crew Cab Standard Box (includes Denali)	L96	Gas	100/850	100/1000	—
	LML	Diesel	100/1000	100/875	—
Crew Cab Long Box (includes Denali)	L96	Gas	100/1000	100/1000	100/925
	LML	Diesel	100/825	100/775	100/700

SRW=Single Rear Wheel DRW=Dual Rear Wheel
 100/xxx=100 lbs maximum of permanently attached snow plow mounting hardware/xxx lbs maximum of removable snow plow blade and blade hardware.
 Maximum plow weights based on a vehicle with average manufacturer option content and 150 lbs each for driver and one additional front-seat occupant. Additional equipment and occupants will reduce maximum plow weight.
 Rear compensating weight may be required to maintain front axle weight below 65% of total vehicle weight when equipped with snow plow. Consult your snow plow manufacturer for specific compensating weight recommendation.

¹Always use safety belts and the correct restraint for your child's age and size. Children are safer when properly secured in a rear seat in the appropriate infant, child or booster seat. Never place a rear-facing infant restraint in the front seat of any vehicle equipped with a passenger air bag. See the Owner's Manual and child safety seat instructions for more safety information. ²Use only GM-approved tire and wheel combinations. For approved tire and wheel combinations and other important information, go to gmaccessorieszone.com or see your dealer for details. ³When properly equipped; includes weight of vehicle, passengers, cargo and equipment. ⁴Cargo and load capacity limited by weight and distribution. ⁵Maximum payload capacity includes weight of driver, passengers, optional equipment and cargo. ⁶Maximum trailer weight ratings are calculated assuming a base vehicle, except for any option(s) necessary to achieve the rating, plus driver. The weight of other optional equipment, passengers and cargo will reduce the maximum trailer weight your vehicle can tow. See your GMC dealer for additional details. ⁷Capacities and weight ratings are dependent upon model, engine, transmission and GVWR combinations. See your GMC dealer for details.

A=Available S=Standard —=Not Available P=Package
 See dealer for availability, inclusions and exclusions.

2500HD WHEELS²



2500HD/3500HD SRW WHEELS²



DENALI HD SRW WHEELS²



3500HD DRW WHEELS²



ENGINES		
	VORTEC 6.0L V-8 VVT (L96)	DURAMAX DIESEL 6.6L V-8 TURBO (LML)
FUEL TYPE	Gasoline	Diesel (B20 biodiesel capable)
CAPACITY	6.0 liters (364 cu. in.)	6.6 liters (402 cu. in.)
SAE NET HORSEPOWER @ RPM	360 @ 5400 (<10,000-lb GVWR) 322 @ 4400 (>10,000-lb GVWR)	397 @ 3000
SAE NET TORQUE @ RPM (LB-FT)	380 @ 4200	765 @ 1600
TRANSMISSIONS:	Electronically controlled 6-speed heavy-duty automatic transmission with overdrive and Tow/Haul mode	Electronically controlled Allison 1000 Series 6-speed automatic transmission with overdrive, electronic engine grade braking and Tow/Haul mode

STANDARD TECHNICAL DATA			CARGO DIMENSIONS ⁴		
	All models: Power 4-wheel antilock braking system			STANDARD BOX	LONG BOX
Series/Drive Type	2WD	4WD	Cargo Volume	60.7 cu. ft.	75.5 cu. ft.
BRAKES	14" dia. 4-wheel disc	14" dia. 4-wheel disc	Inside Width at Floor	62.46"	62.46" - 64.70"
STEERING	Power recirculating ball	Power recirculating ball	Box Length at Floor	78.9"	97.80"
FUEL TANK CAPACITY (APPROX GALS.: STANDARD/LONG BOX)	36.0	36.0			
ALTERNATOR (AMPS)	125	125			

GVWR ³ (Gross Vehicle Weight Rating)	EXTERIOR DIMENSIONS		
	REGULAR CAB	EXTENDED CAB	CREW CAB
2500HD			
Standard Box	—	230.60"	240.20"
Long Box	225.0"	249.50"	259.10"
3500HD			
SRW	10,400	10,700/11,200	10,500/10,700/ 11,100/11,400
DRW	12,800	13,000	13,000

SRW-Single Rear Wheel DRW-Dual Rear Wheel

SELECT RATINGS All capacities in lbs	MAXIMUM PAYLOAD ⁵			MAXIMUM TRAILERING ⁶ Ball Hitch			MAXIMUM TRAILERING ⁶ Fifth-Wheel or Gooseneck		
	2WD/4WD	2WD	4WD	2WD	4WD	2WD	4WD	2WD	4WD
2500HD				Vortec 6.0L V-8/Duramax Diesel 6.6L V-8 Turbo			Vortec 6.0L V-8/Duramax Diesel 6.6L V-8 Turbo		
Regular Cab Long Box	4192/3580	13,000/13,000	13,000/13,000	14,700/17,800	14,400/17,500				
Extended Cab Standard Box	3506/3222	13,000/13,000	13,000/13,000	14,300/17,500	14,000/17,200				
Extended Cab Long Box	3404/3130	13,000/13,000	13,000/13,000	14,200/17,400	13,900/16,500				
Crew Cab Standard Box	3385/3123	13,000/13,000	13,000/13,000	14,200/17,400	13,900/16,700				
Denali Crew Cab Standard Box	3200/2959	13,000/13,000	13,000/13,000	14,000/17,200	13,700/15,600				
Crew Cab Long Box	3292/3375	13,000/13,000	13,000/13,000	14,100/17,200	13,800/15,600				
3500HD									
Regular Cab SRW	4632/4566	13,000/—	13,000/13,000	14,500/—	14,200/17,400				
DRW	6635/6308	14,100/—	13,800/16,000	14,100/—	13,800/21,700				
Extended Cab SRW	4397/4420	13,000/13,000	13,000/13,000	14,000/17,300	13,700/16,900				
DRW	6332/6055	13,600/16,500	13,400/17,000	13,600/21,500	13,400/21,300				
Crew Cab SRW	4416/4268	13,000/13,000	13,000/13,000	14,000/17,300	13,700/17,000				
Denali SRW	4039/4066	13,000/13,000	13,000/13,000	13,800/17,100	13,600/16,800				
DRW	6223/5905	13,500/16,500	13,200/17,000	13,500/21,500	13,200/21,100				
Denali DRW	6051/5733	13,000/16,500	13,000/17,000	13,400/21,300	13,000/21,000				

FRONT SUSPENSION ⁷ Independent torsion bar	
STANDARD FRONT AXLE CAPACITY (2500HD/3500HD)	2WD
Regular Cab (lbs)	4400/4800
Extended Cab (lbs)	4400/5200
Crew Cab (lbs)	4400/5600
STANDARD FRONT SPRING CAPACITY	
Regular Cab (lbs)	4400/4800
Extended Cab (lbs)	4400/5200
Crew Cab (lbs)	4400/5200

FRONT SUSPENSION ⁷ Independent torsion bar	
STANDARD FRONT AXLE CAPACITY (2500HD/3500HD)	4WD
Regular Cab (lbs)	4400/5200
Extended Cab (lbs)	4400/5600
Crew Cab (lbs)	4800/5600
STANDARD FRONT SPRING CAPACITY	
Regular Cab (lbs)	4400/5200
Extended Cab (lbs)	4800/5600
Crew Cab (lbs)	4800/5600

REAR SUSPENSION ⁷ Semi-elliptical multileaf—2500HD, 3500HD	
REAR AXLE CAPACITY (2500HD/3500HD -SRW/3500HD-DRW)	2WD/4WD
Regular Cab (lbs)	6200/7050/9375
Extended Cab (lbs)	6200/7050/9375
Crew Cab (lbs)	6200/7050/9375
REAR SPRING CAPACITY	
Regular Cab (lbs)	6200/7050/9375
Extended Cab (lbs)	6200/7050/9375
Crew Cab (lbs)	6200/7050/9375

SRW-Single Rear Wheel DRW-Dual Rear Wheel

GMC SIERRA HD

GMC ACCESSORIES

Available dealer-installed GMC Accessories include a variety of items designed to enhance your Sierra HD's functionality. In addition to those shown on this page, the Sierra HD shown on page 27 features 6-inch oval chrome assist steps,¹ roof-mounted luggage cross rails and a soft tonneau cover.

STATIONARY TOOLBOX



Diamond-patterned toolbox features dual gas shocks for smooth opening and closing and GMC logo.

OVERHEAD UTILITY RACK



The overhead utility rack mounts to the available Cargo Management System rails and supports up to 500 lbs.² The rear supports slide along the Cargo Management System rails to enhance functionality.

BED-MOUNTED TIE-DOWN HOOKS



Four bright stainless steel hooks mount in the stake pockets of the pickup bed, remain out of sight when not in use and pop up to help secure cargo.

ASSIST STEPS¹



Make it easier to get in and out of your truck with these stylish assist steps. Crafted from rust-resistant stainless steel, they are available in either chrome or black powder coat and in 6-inch oval or 3-inch round styles.

PREMIUM ALL-WEATHER FLOOR MATS



Designed to conform to the floor, mats feature a custom, deep-ribbed pattern to collect debris for easy cleaning.

SLIDING TOOLBOX AND BED DIVIDER



Protect your tools and cargo with a sliding bed divider, toolbox and side-storage toolbox. Toolboxes feature diamond-patterned construction and codable lock technology.

BEDLINER



Help protect the bed of your Sierra HD with a durable form-fitting bedliner and tailgate liner. Available for all bed lengths, with designs that fit with or without Cargo Management System rails, the bedliner is fully ribbed, with a skid-resistant floor to help minimize load shifting.

OVERHEAD BED DIVIDERS



Add cargo management versatility to your truck bed with these overhead bed dividers. Both racks attach and slide on the Cargo Management System rails, and the front rack flips down to serve as a bed divider. Requires Center High-Mounted Stop Lamp (CHMSL).

¹Also offered as a dealer-ordered accessory option. ²Cargo and load capacity limited by weight and distribution.



design by
U

SIERRA 2500HD CREW CAB SLT IN PURE SILVER METALLIC SHOWN WITH AVAILABLE EQUIPMENT AND DEALER-INSTALLED ACCESSORIES: 6" OVAL CHROME ASSIST STEPS, ROOF-MOUNTED LUGGAGE CROSS RAILS, SOFT TONNEAU COVER, CHROME DOOR HANDLES AND CHROME MIRROR CAPS

GMC SIERRA HD

COLORS

ONYX BLACK



STEALTH GRAY METALLIC



STORM GRAY METALLIC¹



MIDNIGHT BLUE METALLIC¹



SUMMIT WHITE



GRAY GREEN METALLIC¹



FIRE RED¹



PURE SILVER METALLIC¹



WT TRIM

VINYL

(Standard: WT trim)



DARK TITANIUM

SLE TRIM

PREMIUM CLOTH

(Standard: SLE trim)



LIGHT TITANIUM



LIGHT CASHMERE



EBONY

SLT TRIM

ULTRASOFT LEATHER-APPOINTED

(Standard: SLT trim; Available: SLE trim)



LIGHT TITANIUM



LIGHT CASHMERE



EBONY

DENALI

NUANCE LEATHER-APPOINTED

(Standard: Sierra Denali)

PERFORATED NUANCE LEATHER-APPOINTED

(Standard: Sierra Denali with heated and cooled seats)



COCOA/LIGHT CASHMERE



EBONY/EBONY LEATHER

¹Not available on Sierra Denali models. All colors are basecoat/clearcoat for high-gloss and durable finish. See dealer for more details on color and trim options.



FROM THE GMC TERRAIN, DESIGNED TO OFFER BEST-IN-CLASS 32 HIGHWAY MPG,¹ TO A FAMILY OF FULL-SIZE HYBRID SUVs AND PICKUPS NO OTHER COMPETITOR CAN OFFER, WE ENGINEER PRACTICAL WISDOM AND REMARKABLE CAPABILITY INTO OUR ENTIRE LINE OF VEHICLES.

FOR 2011, THE ACADIA DENALI INTRODUCES NEW LEVELS OF LUXURY TO GMC'S HIGHLY SUCCESSFUL PREMIUM CROSSOVER, WHILE THE REDESIGNED SIERRA HD ADDS BEST-IN-CLASS POWER, PAYLOAD AND TRAILERING CAPABILITY TO OUR RENOWNED LINE OF PICKUPS.²

POWERFUL AND FUEL-EFFICIENT ENGINES, COMPREHENSIVE SAFETY FEATURES AND THOUGHTFUL INNOVATIONS PROVIDE AN UNEXPECTED COMBINATION OF PERFORMANCE, TECHNOLOGY AND CONVENIENCE. THAT'S WHAT HAPPENS WHEN YOUR ENGINEERS NEVER SAY NEVER.

THAT'S GMC. WE ARE PROFESSIONAL GRADE.



ONSTAR

OnStar is a core asset of your Sierra. Benefiting from more than a decade of innovative development, it is both a highly advanced technology—fully integrated within the vehicle—and a warm human service. Standard on most Sierra models are six months of the OnStar Directions & Connections plan, including the convenience of Hands-Free Calling. It also includes Automatic Crash Response (see page 19), Stolen Vehicle Assistance, link to Emergency Services, Roadside Assistance, Remote Door Unlock, OnStar Vehicle Diagnostics, Crisis Assist and Remote Horn and Lights. OnStar services require vehicle electrical system (including battery), wireless service and GPS satellite signals to be available and operating for features to function properly. OnStar acts as a link to existing emergency service providers. Subscription Service Agreement required. Call 1-888-4ONSTAR (466-7827) or visit onstar.com for OnStar's Terms and Conditions, Privacy Policy, coverage maps, details and system limitations. Services vary with conditions.

HANDS-FREE CALLING

OnStar Hands-Free Calling capability is built into your Sierra. It's there when your cell phone is unavailable, its battery is low, you can't reach it easily or you left it home or in the office. Your Hands-Free Calling system is the right choice whenever you need an easy way to make and receive calls—at the touch of the phone icon on the rearview mirror or the steering-wheel-mounted controls shown on page 16. Voice-activated dialing is convenient because you don't have to dial when you are at the wheel. And Hands-Free Calling is reliable because it's specially designed for better reception and fewer dropped calls in areas of limited cellular reception. You are invited to experience the benefits yourself with 30 Hands-Free Calling minutes—on OnStar—during the first two months you drive your Sierra, with no strings attached.

ONSTAR TURN-BY-TURN NAVIGATION

Standard on Sierra HD SLE, SLT, and Denali models are six months of the OnStar Directions & Connections plan that adds innovative, easy-to-use Turn-by-Turn Navigation plus Information and Convenience Services and Driving Directions. With Turn-by-Turn Navigation, you simply tell the OnStar Advisor your intended destination, and directions will automatically be sent to your Sierra. If you drive off-course, the system can reroute you to your intended destination. An automated voice then guides you turn-by-turn until you arrive at your destination. Turn-by-Turn Navigation is further enhanced with eNAV, allowing you to send MapQuest® directions directly to your vehicle. No need to print out directions; just call them up with simple voice commands.



XM RADIO

On all Sierra models except WT: XM Radio¹ is standard with 3 trial months of service. XM turns your drive on with commercial-free music channels from virtually every genre, artist-dedicated channels, live performances and more. Tune in to live play-by-play from the biggest sports, exclusive entertainment from top personalities, compelling talk, hilarious comedy, world-class news, local traffic and weather and family-friendly programming. Everything worth listening to is now on XM. Visit gm.xmradio.com for details.



XM NAVTRAFFIC

Included with the available Touch-Screen Navigation System, XM NavTraffic² enhances Sierra's GPS navigation system by showing real-time traffic data—while you're driving. Available in over 80 markets, XM NavTraffic displays construction, road closures and accidents so that you can get to your destination faster, plus average traffic speed and estimated drive time in select markets. For more information, visit xmradio.com/navtraffic.



GOODWRENCH SERVICE

To help your Sierra live up to its performance promise, GMC Goodwrench Service—found exclusively at your GMC dealer—is there. With all the engineering excellence in Sierra, GM-trained Goodwrench technicians have the expertise to care for all of it.

¹XM Radio requires a subscription, sold separately by XM after the first 90 days. XM Radio U.S. service only available in the 48 contiguous United States and the District of Columbia. For more information, visit gm.xmradio.com.

²Required XM Radio and NavTraffic monthly subscriptions sold separately by XM after trial period. XM NavTraffic only available in select markets. For more information, visit xmradio.com/navtraffic.



COMMITMENT PLUS

From the owner orientation—and full tank of gas—you receive when you take possession of your Sierra to the **24-Hour Roadside Assistance, Courtesy Transportation** and **Travel Benefits**, Commitment Plus is a portfolio of owner privileges that lasts throughout your warranty. For expert product information, Roadside Assistance or other services, call 1-800-GMC-8782.

TRAVEL BENEFITS AND ROADSIDE ASSISTANCE Available around the clock: trip routing service, a program for reimbursement for trip interruption due to necessary warranty repairs, towing, flat tire change, jump-starts and more for 5 years or 100,000 miles (whichever comes first).

COURTESY TRANSPORTATION Available at participating dealers: shuttle service, reimbursement of certain public transportation or fuel expenses for overnight warranty repairs, and courtesy rental for overnight work repairs. See your dealer for details.

GMC OWNER CENTER A complimentary, one-stop resource to enhance your GMC ownership experience. It's easy to sign up. Just go to gm.com/gmownercenter/gmc.

BEST COVERAGE IN AMERICA Sierra offers the best coverage in America. That means you get all the benefits of Commitment Plus, including Roadside Assistance and Courtesy Transportation. In addition, you get a new level of confidence with GM's 5-Year/100,000-Mile Transferable Powertrain Limited Warranty. Whichever comes first. See Goodwrench dealer for details.

A NOTE ON CHILD SAFETY Always use safety belts and the correct restraint for your child's age and size. Children are safer when properly secured in a rear seat in the appropriate infant, child or booster seat. Never place a rear-facing infant restraint in the front seat of any vehicle equipped with a passenger air bag. See the Owner's Manual and child safety seat instructions for more safety information.

TRAILERING AND OFF-ROAD INFORMATION Please carefully review the Owner's Manual for important safety information about trailering or off-road driving in your vehicle.

IMPORTANT WORDS ABOUT THIS CATALOG We have tried to make this catalog comprehensive and factual. We reserve the right, however, to make changes at any time, without notice, in prices, colors, materials, equipment, specifications, models and availability. Specifications, dimensions, measurements, ratings and other numbers in this catalog and other printed materials provided at the dealership or affixed to vehicles are approximates based upon design and engineering drawings and prototypes and laboratory tests. Your vehicle may differ due to variations in manufacture and equipment. Since some information may have been updated since the time of printing, please check with your GMC dealer for complete details. GMC reserves the right to lengthen or shorten the model year for any product for any reason, or to start and end model years at different times. Some standard content may be deleted with fleet orders. See dealer for details.

ENGINES GMC products are equipped with engines produced by GM Powertrain or other suppliers to GM worldwide. The engines in GMC products may also be used in other GM makes and models.

GMC.COM See more of Sierra on our Web site: gmc.com/sierra. More photos and information; hot links to related subjects; convenient dealer locator; pricing guide, spec out your own vehicle. Or call 1-800-GMC-8782.

AN IMPORTANT NOTE ABOUT ALTERATIONS AND WARRANTIES Installations or alterations to the original equipment vehicle (or chassis) as distributed by General Motors are not covered by the General Motors New-Vehicle Limited Warranty. The special body company, assembler, equipment installer or upfitter is solely responsible for warranties on the body or equipment and any alterations (or any effect of the alterations) to any of the parts, components, systems or assemblies installed by GM. General Motors is not responsible for the safety or quality of design features, materials or workmanship of any alterations by such suppliers.

NEW-VEHICLE LIMITED WARRANTY All GMC light-duty vehicles come with a fully transferable, no-deductible 5-year/100,000-mile (whichever comes first) Powertrain Limited Warranty. GM vehicles registered in the U.S.A. are also covered for 3 years or 36,000 miles (whichever comes first). Coverage includes tires and towing to your nearest GMC dealership. Repairs will be made to correct any vehicle defect and most warranty repairs will be made at no charge. In addition, rust-through corrosion will be covered for 6 years or 100,000 miles (whichever comes first). See dealer for details.

ASSEMBLY GMC vehicles and their components are assembled or produced by different operating units of General Motors, its subsidiaries or suppliers to GM worldwide. We sometimes find it necessary to produce GMC vehicles with different or differently sourced components than originally scheduled. Since some options may be unavailable when your vehicle is assembled, we suggest that you verify that your vehicle includes the equipment you ordered or, if there are changes, that they are acceptable to you.

GMMOBILITY.COM (1-800-323-9935) GM Mobility offers financial assistance for eligible adaptive equipment to make automotive travel easier for persons with disabilities or special transportation needs. To learn more about special GM Mobility offers, visit gmmobility.com.

GMCARDMEMBERSERVICES.COM Did you know about the family of reward credit cards that can help you get a great deal on a new GM car, light-duty truck, SUV or crossover? With a GM reward card, you accrue earnings on every credit card purchase to use toward the purchase or lease of an eligible new GM vehicle. With three cards to choose from, you're sure to find one that suits you.

©2010 General Motors. All rights reserved. GM, the GM logo, GMC, the slogans, emblems, vehicle model names, vehicle body designs and other marks appearing in this catalog are the trademarks and/or service marks of General Motors, its subsidiaries, affiliates or licensors. Bose, Centerpoint, AudioPilot and SurroundStage are registered trademarks of the Bose Corporation. iPod is a registered trademark of Apple, Inc. Facebook is a registered trademark of Facebook, Inc.



GMC.COM | LEARN MORE ABOUT GMC, AND JOIN THE DIALOGUE ON FACEBOOK

